

NOTE: The cover page of this standard has been changed for administrative reasons. There are no other changes to this document.

INCH POUND

MIL-STD-2161A (AS)
1 May 1993
SUPERSEDING
MIL-STD-2161 (AS)
18 April 1985

DEPARTMENT OF DEFENSE STANDARD PRACTICE

PAINT SCHEMES AND EXTERIOR MARKINGS FOR US NAVY AND MARINE CORPS AIRCRAFT



AMSC N/A

AREA MFFP

MIL-STD-2161A(AS)

FOREWORD

1. This military standard is approved for use by the Naval Air Systems Command and is available for use by all Departments and Agencies of the Department of Defense.
2. Beneficial comments (recommendations, additions, deletions) and any pertinent data which may be of use in improving this document should be addressed to: Commanding Officer, Naval Air Warfare Center - Aircraft Division Lakehurst, Systems Requirements Department (Code SR3), Lakehurst, NJ 08733-5100, by using the self-addressed Standardization Document Improvement Proposal (DD Form 1426) appearing at the end of this document or by letter.
3. In furtherance of the Defense Standardization Program and to provide a single point of reference that gives clear and concise direction for the paint schemes and exterior markings for U.S. Navy and Marine Corps aircraft, this document has been prepared to be a readily available reference source to all concerned.
4. This standard contains integrated instructions for paint schemes and exterior marking for U.S. Navy and Marine Corps aircraft.
5. For additional guidance on the contents of this document, contact the Naval Air Systems Command, Attention: (AIR 5164), Washington, DC 20361-5110, the Naval Air Warfare Center - Aircraft Division, Lakehurst (at the above address), or the appropriate Naval Aviation Depot.

MIL-STD-2161A(AS)

CONTENTS

<u>PARAGRAPH</u>		<u>PAGE</u>
1.	SCOPE	1
1.1	General	1
1.2	Purpose	1
1.3	Foreign government aircraft	1
1.4	Military aircraft used in research projects . . .	1
2.	APPLICABLE DOCUMENTS	2
2.1	Government documents	2
2.1.1	Specifications and standards	2
2.1.2	Other Government publications	3
2.2	Order of precedence	4
3.	DEFINITIONS	5
3.1	Tactical paint scheme	5
3.2	Land camouflage paint scheme	5
4.	GENERAL REQUIREMENTS	6
4.1	Paint schemes and insignia markings	6
4.2	Material	6
4.2.1	Finishes	6
4.2.2	Compatibility	6
4.2.3	Applicable limitation	6
4.2.4	Metal marking instruments	6
4.2.5	External finish identification	6
4.2.5.1	Record of finish application	7
4.3	Drawings	7
4.4	Service requirements	7
4.5	Foreign government aircraft	7
4.6	Color and style of marking materials and paint schemes	8
4.6.1	Color standard	8
5	DETAILED REQUIREMENTS	9
5.1	Aircraft paint schemes	9
5.1.1	High visibility color configurations	9
5.1.1.1	Application and color patterns	9
5.1.2	Arctic paint scheme	10
5.1.3	Tactical paint schemes	10
5.1.3.1	Tactical paint scheme materials	10
5.1.3.2	Tactical paint scheme patterns	10
5.1.3.2.1	Aircraft surfaces	11
5.1.3.2.2	Bottom surfaces	11
5.1.4	Paint scheme for drones	11

MIL-STD-2161A(AS)

CONTENTS

<u>PARAGRAPH</u>		<u>PAGE</u>
5.1.5	Paint scheme for target aircraft	11
5.1.6	Solar heat reflection	11
5.1.7	Antiglare	11
5.1.8	Glass fiber reinforced plastic assemblies	12
5.1.9	Landing gear	12
5.1.9.1	Fixed landing gear	12
5.1.9.2	Retractable landing gear	12
5.1.10	Speed brakes, wing flaps, etc	12
5.1.11	Wing leading edge slats	12
5.1.12	Walkways and steps	13
5.1.13	External stores (including ordnance)	13
5.1.14	Radomes, antennae, and antennae covers	13
5.1.15	Helicopter blades, hubs, transmissions and rotor mechanisms	13
5.1.15.1	Rotor blades	13
5.1.15.2	Hubs of helicopters	13
5.1.15.3	Transmission and rotor mechanisms of helicopters	13
5.1.16	Jet air intake ducts	14
5.1.17	Propeller assemblies	14
5.1.17.1	Blades	14
5.1.17.2	Spinners	14
5.1.17.3	Hubs and domes	14
5.1.18	Engine cowling interiors	14
5.2	Aircraft exterior markings	14
5.2.1	Identification marking	14
5.2.1.1	Letter and numeral (character) construction	15
5.2.1.1.1	Helicopters	15
5.2.1.1.2	Research aircraft	15
5.2.1.1.3	Experimental aircraft	15
5.2.1.1.4	Target aircraft and guided missiles	15
5.2.1.1.5	Target aircraft	16
5.2.1.1.6	Test and evaluation (T&E) aircraft	16
5.2.2	Mandatory markings for U.S. Navy and Marine Corps aircraft	16
5.2.2.1	Changes	16
5.2.2.2	Application	18
5.2.2.3	National star insignia	18
5.2.2.4	Branch of service marking	18
5.2.2.4.1	Branch of service marking - style	18
5.2.2.4.2	Branch of service marking - size and location	18
5.2.2.5	Model designation and bureau airplane serial number (BUNO)	18

MIL-STD-2161A(AS)

CONTENTS

<u>PARAGRAPH</u>		<u>PAGE</u>
5.2.2.5.1	Model designation and BUNO - location	18
5.2.2.5.2	Size	18
5.2.2.6	Unit aircraft number	19
5.2.2.6.1	Location	19
5.2.2.6.2	Size	19
5.2.2.7	Unit identifier	19
5.2.2.7.1	Location	19
5.2.2.7.2	Size	19
5.2.2.8	Station or unit name	19
5.2.2.8.1	Location	19
5.2.2.8.2	Size	19
5.2.2.9	Call numbers	20
5.2.2.9.1	Location	20
5.2.2.9.2	Size	20
5.2.2.10	Mandatory safety markings	20
5.2.2.10.1	Jet engine intake warning chevrons and signs	20
5.2.2.10.1.1	Application	20
5.2.2.10.1.2	Variations	21
5.2.2.10.2	Jet engine blast warning	21
5.2.2.10.3	Propeller, rotor, and turbine safety markings	21
5.2.2.10.3.1	Main rotor blades	21
5.2.2.10.3.1.1	Matched sets	21
5.2.2.10.3.1.2	Unmatched sets	21
5.2.2.10.3.1.3	Static balance - preservation and maintenance	21
5.2.2.10.3.1.4	Classification numbers	22
5.2.2.10.3.2	Tail rotor blades	22
5.2.2.10.3.3	Helicopter tail boom - warning marking	23
5.2.2.10.3.4	Helicopter tail rotor - guards and stabilizers	23
5.2.2.10.3.5	Propeller blades - warning markings	23
5.2.2.10.3.6	Fuselage propeller - warning stripe and signs	24
5.2.2.10.3.7	Bomb bay, hatch, etc., - exit warning stripe and signs	24
5.2.2.10.3.8	Staggered engines	24
5.2.2.10.4	Arresting hooks	24
5.2.2.10.4.1	Arresting hook warning marking	25
5.2.2.10.5	Loose and jettisonable equipment	25
5.2.2.10.6	Identification and markings of emergency escape system	25
5.2.2.10.6.1	Application	25
5.2.2.10.6.2	Location	25
5.2.2.10.6.3	Lettering size	25
5.2.2.10.6.4	Cutout area marking	25

MIL-STD-2161A(AS)

CONTENTS

<u>PARAGRAPH</u>		<u>PAGE</u>
5.2.2.10.6.5	Exit control lever markings	26
5.2.2.10.6.6	Fire access panel marking	26
5.2.2.10.6.7	Explosive-actuated devices	26
5.2.2.10.6.8	Axe and crowbar	26
5.2.2.10.6.9	Fire extinguishers	26
5.2.2.10.6.10	Asbestos gloves	26
5.2.2.10.6.11	First-aid kit	26
5.2.2.10.6.12	Ejection seat markings	27
5.2.2.10.6.12.1	Ejection seat markings for multiplace aircraft	27
5.2.2.10.6.12.2	Other cartridge-actuated escape systems	27
5.2.2.10.6.13	Canopy release markings	27
5.2.2.10.6.14	External exit emergency release	27
5.2.2.10.6.15	Transport aircraft	27
5.2.2.10.6.15.1	Internal removable escape panels	28
5.2.2.10.6.15.2	Emergency exit marking	28
5.2.2.10.6.15.3	Handles, releases, catches, and knobs for inside panels	28
5.2.2.10.6.15.4	External removable escape panels	28
5.2.2.10.6.15.5	Markings for forced emergency entry or exit	29
5.2.2.10.6.15.6	Secondary openings	29
5.2.3	Tactical and land camouflage paint scheme markings	29
5.2.3.1	Color of markings on land camouflage scheme painted aircraft	29
5.2.3.2	Color of markings for aircraft with tactical paint schemes	30
5.2.3.2.1	Tactical paint scheme - general marking policy	30
5.2.3.2.2	Color of MODEX numbers	30
5.2.3.3	Size of markings when used on aircraft with tactical or land camouflage paint schemes	30
5.2.3.4	Paint scheme deviations approval	30
5.2.4	Marking materials	30
5.2.5	Exterior maintenance precautionary and warning markings	31
5.2.5.1	Aircraft and missile service point identification symbols and markings	31
5.2.5.1.1	Application of service point identification symbols and marking	31
5.2.5.1.2	Location	31
5.2.5.1.3	Hydraulic system and landing gear/struts	31
5.2.5.2	Fuel nozzle jumper plug receptacles	31

MIL-STD-2161A(AS)

CONTENTS

<u>PARAGRAPH</u>		<u>PAGE</u>
5.2.12.2.1	Mixture control lever	39
5.2.12.3	Fuel system diagram	39
5.2.13	Fluid line identification	39
5.2.13.1	Color code (identification chart)	39
5.2.14	Parts markings	40
5.2.15	Reworked or special parts	40
5.2.16	Identification of tubes, hoses, and pipelines for aircraft	40
5.2.17	North Atlantic Treaty Organization (NATO) code numbers	40
5.2.18	Data cards	40
5.2.19	Marking of loose and jettisonable equipment	40
5.2.20	Identification of escape system ballistic hose and tubing	41
5.2.20.1	Propellant gas system	41
5.2.20.2	Escape subsystem	41
5.2.20.3	Hose, tubing, and detonating cord assemblies	41
5.2.20.4	Ground rescuer marking of hose and tubing assemblies	41
5.2.21	Emergency light switch	41
5.2.22	Dinghy (raft) release and flotation controls	41
5.3	Workmanship	42
6.	NOTES	43
6.1	Intended use	43
6.2	Issue of DODISS	43
6.3	Data requirements	43
6.4	Toxicity	43
6.4.1	Personnel protective methods	43
6.5	Subject term (key word) listing	44
6.6	International standardization	44
6.7	Changes from previous issue	44

APPENDICES

APPENDIX A

Appendix A

STANDARD MARKING, EMERGENCY AND HAZARD
WARNING MARKINGS FOR AIRCRAFT

<u>PARAGRAPH</u>		<u>PAGE</u>
10.	SCOPE	45
10.1	Scope	45

MIL-STD-2161A(AS)

CONTENTS

<u>PARAGRAPH</u>		<u>PAGE</u>
5.2.5.3	Aircraft grounding points	31
5.2.5.4	Storage batteries	32
5.2.5.5	Instrument static opening markings	32
5.2.5.6	Wing fold warning flag	32
5.2.5.7	Markings for electrical connections	32
5.2.5.8	Markings for engine removal	32
5.2.5.9	Markings for tank and filler areas	32
5.2.5.9.1	Tank	32
5.2.5.9.2	Filler caps	33
5.2.5.10	Lift points, hand grips, caution legends, etc	33
5.2.5.11	Baggage compartment, life raft stowage, etc	33
5.2.5.12	Wing access panel latches and safety straps	33
5.2.5.13	Actuating mechanism warning signs	33
5.2.5.14	Recessed lubrication fittings	33
5.2.6	Optional markings	33
5.2.6.1	Squadron designation	33
5.2.6.2	Reserve aircraft markings - station names	34
5.2.6.3	Battle "E"	34
5.2.6.4	Safety "S"	34
5.2.6.5	Hospital aircraft red cross	35
5.2.6.6	Aircraft pilot and crew chief names	35
5.2.7	Special purpose marking for U.S. Navy aircraft	35
5.2.7.1	Identification of naval attache (ALUSNA) aircraft	35
5.2.7.1.1	Fuselage marking	35
5.2.7.1.2	Naval attache fuselage marking	35
5.2.7.1.2.1	Location	36
5.2.7.1.2.2	Size	36
5.2.7.1.3	Naval attache wing marking	36
5.2.7.1.3.1	Location	36
5.2.7.1.3.2	Size	36
5.2.7.1.4	Naval attache vertical stabilizer marking	36
5.2.7.1.4.1	Location	37
5.2.7.2	Standard American flag sizes	37
5.2.7.3	Presidential helicopter	37
5.2.8	Marking of foreign aircraft	37
5.2.9	Access panel identification	37
5.2.10	Walkways and honeycomb panels	38
5.2.10.1	Walkways and steps	38
5.2.11	Honeycomb panels on airplanes	38
5.2.12	Powerplant	38
5.2.12.1	Powerplant removal	38
5.2.12.2	Powerplant controls	38

MIL-STD-2161A(AS)

CONTENTS

<u>PARAGRAPH</u>		<u>PAGE</u>
10.2	Use	45
20.	APPLICABLE DOCUMENTS	45
20.1	Government documents	45
20.1.1	Specifications and standards	45
20.2	Order of precedence	46
30.	DEFINITIONS	46
30.1	Definitions	46
40.	GENERAL REQUIREMENTS	46
40.1	National insignia	46
40.1.1	National insignia design	46
40.1.1.1	Size	46
40.1.1.2	Color	47
40.1.1.3	Application	47
40.1.2	Wing insignia	47
40.1.3	Fuselage or hull insignia	47
40.1.4	Rotary wing aircraft insignia	48
40.1.5	Decalcomanias	48
40.1.6	Decalcomania letter heights	48
40.1.7	Tactical and land camouflage paint scheme national insignia	48
40.2	Aircraft markings	48

FIGURES

<u>FIGURE</u>		<u>PAGE</u>
A-1	National star insignia	49
A-2	National star insignia on swept wing aircraft	50
A-3	Arresting hook warning	50
A-4	Form of letters and numerals	51
A-5	Color scheme for helicopter blades	53
A-6	Color scheme for reciprocating single and multi engine aircraft propellers	54
A-7	Marking for fire access panel	55
A-8	Warning chevron and signs applied adjacent to jet engine intake and exhaust	56
A-9	Propeller warning strips and signs	57
A-10	Canopy release location	58
A-11	Warning decal	58
A-12	Helicopter tail boom markings	59
A-13	Canopy release markings	59

MIL-STD-2161A(AS)

CONTENTS

FIGURES

<u>FIGURE</u>		<u>PAGE</u>
A-14	Representative tactical and land camouflage paint scheme markings	60
A-15	Representative tactical and land camouflage paint scheme markings	61
A-16	Representative tactical and land camouflage paint scheme markings	62
A-17	Area cutout markings	63
A-18	American flag dimensions shall be in accordance with DDD-F-416	64
A-19	Geneva red cross	65
A-20	Placard installation-identification, emergency escape hatch	66

APPENDIX B

Appendix B SERVICING, GROUND HANDLING, HAZARD WARNING
MARKINGS, AND ARMAMENT PLACARD FOR AIRCRAFT

<u>PARAGRAPH</u>		<u>PAGE</u>
10.	SCOPE	67
10.1	Scope	67
10.2	Use	67
20.	APPLICABLE DOCUMENTS	67
20.1	Government documents	67
20.1.1	Specifications and standards	67
20.1.2	Other Government publications	70
20.2	Non-Government publications	70
20.3	Order of precedence	70
30.	DEFINITIONS	71
30.1	Definitions	71
40.	GENERAL REQUIREMENTS	71
40.1	Servicing and precautionary marking	71
40.2	Servicing instructions	72
40.3	Service warning markings	72
40.4	Printed information	72
40.5	Colors	72
40.6	International standardization	72
50.	DETAIL REQUIREMENTS	73
50.1	Aircraft markings and placard	73

MIL-STD-2161A(AS)

CONTENTS

FIGURES

<u>FIGURE</u>		<u>PAGE</u>
B-1	Typical symbol dimensioning	74
B-2	Armament placard	74
B-3	NATO codes and markings-filling	75
B-4	NATO codes and markings-filling, ground handling and hazards	76
B-5	NATO code number cross reference	77
B-6	Typical NATO aircraft servicing markings	82
B-7	Required markings and symbols	83
B-8	Decalomania - ground here, international symbol	86
B-9	Samples of ground servicing and hazard markings (size and color)	87
B-10	Record of finish marking	91

APPENDIX C

Appendix C FIGHTER, ATTACK, CARGO, UTILITY, TRAINER,
AND SEARCH AND RESCUE (SAR) AIRCRAFT MARKING

<u>PARAGRAPH</u>		<u>PAGE</u>
10.	SCOPE	92
10.1	Scope	92
10.2	Use	92
20.	APPLICABLE DOCUMENTS	92
30.	DEFINITIONS	92
30.1	Definitions	92
40.	GENERAL REQUIREMENTS	92
40.1	Aircraft paint schemes	92

FIGURES

<u>FIGURE</u>		<u>PAGE</u>
C-1	A-3B aircraft marking	93
C-2	A/TA-4 aircraft marking (tactical)	95
C-3	A/TA-4 aircraft marking (high visibility)	97
C-4	A-6 aircraft marking (tactical)	99
C-5	A-7 aircraft marking (tactical)	101
C-6	AV-8B aircraft marking (land camouflage)	103

MIL-STD-2161A(AS)

CONTENTS

FIGURES

<u>FIGURE</u>		<u>PAGE</u>
C-7	C-1A aircraft marking	105
C-8	C-2A aircraft marking	107
C-9	C-118 aircraft marking (cargo)	109
C-10	C-130 aircraft marking (arctic)	111
C-11	C-130 aircraft marking (cargo/tanker/tacamo)	113
C-12	C-130 aircraft marking (tactical)	115
C-13	C-131 aircraft marking (cargo)	117
C-14	E-2C aircraft marking	119
C-15	EA-6B aircraft marking (tactical)	121
C-16	RF/F-4 aircraft marking (tactical)	123
C-17	RF-8G aircraft marking (tactical)	125
C-18	F-14 aircraft marking (tactical)	127
C-19	F-18 aircraft marking (tactical)	129
C-20	AH-1J/1T/1W aircraft marking (tactical)	131
C-21	UH-1E aircraft marking (SAR)	133
C-22	UH-1E aircraft marking	135
C-23	HH-1K aircraft marking (land camouflage)	137
C-24	UH-1N aircraft marking	139
C-25	UH-1N aircraft marking (non-combat SAR)	141
C-26	UH-1N aircraft marking (tactical)	143
C-27	TH-1L aircraft marking	145
C-28	SH-2 aircraft marking (tactical)	147
C-29	HH-3A/UH-3A aircraft marking	149
C-30	SH-3G aircraft marking (high visibility) (SAR)	151
C-31	HH-46A aircraft marking (high visibility) (SAR)	153
C-32	CH-46E aircraft marking (tactical)	155
C-33	UH-46A/D aircraft marking	157
C-34	CH-53 aircraft marking (land camouflage)	159
C-35	CH-53D/RH-53D aircraft marking (tactical)	161
C-36	CH-53E aircraft marking (Navy) (tactical)	163
C-37	CH-53E aircraft marking (Marine) (tactical)	165
C-38	SH-60B aircraft marking (tactical)	167
C-39	OV-10A aircraft marking (tactical)	169
C-40	OV-10D aircraft marking (tactical)	171
C-41	P-3 aircraft marking	173
C-42	S-3A/B aircraft marking (tactical)	175
C-43	T-2B/C aircraft marking (high visibility)	177
C-44	T-34C aircraft marking (high visibility)	179
C-45	T-39 aircraft marking (high visibility)	181
C-46	T-39 aircraft marking (cargo)	183
C-47	T-44A aircraft marking (high visibility)	185
C-48	UC-12B aircraft marking	187

MIL-STD-2161A(AS)

CONTENTS

APPENDIX E

Appendix E

TACTICAL PAINT SCHEMES

<u>PARAGRAPH</u>		<u>PAGE</u>
10.	SCOPE	222
10.1	Scope	222
10.2	Use	222
20.	APPLICABLE DOCUMENTS	222
30.	DEFINITIONS	222
30.1	Definitions	222
40.	GENERAL REQUIREMENTS	222
40.1	Aircraft paint scheme	222

FIGURES

<u>FIGURE</u>		<u>PAGE</u>
E-1	A/TA-4 tactical paint scheme	223
E-2	A-6 tactical paint scheme	225
E-3	A-7 tactical paint scheme	227
E-4	AV-8B land camouflage paint scheme	229
E-5	EA-6B tactical paint scheme	231
E-6	RF/F-4 tactical paint scheme	233
E-7	F-14 tactical paint scheme	235
E-8	F-18 tactical paint scheme	237
E-9	SH-60B tactical paint scheme	239
E-10	RF-8G tactical paint scheme	241
E-11	S-3A/B tactical paint scheme	243
E-12	SH-2F tactical paint scheme	245
E-13	SH-3D/H tactical paint scheme	247
E-14	AH-1J/1T/1W tactical paint scheme	249
E-15	UH-1N tactical paint scheme	251
E-16	HH-1K land camouflage paint scheme	253
E-17	CH-46E tactical paint scheme	255
E-18	CH-53D/RH-53D tactical paint scheme	257
E-19	CH-53E tactical paint scheme	259
E-20	OV-10A tactical paint scheme	261
E-21	OV-10D tactical paint scheme	263

MIL-STD-2161A(AS)

CONTENTS

FIGURES

<u>FIGURE</u>		<u>PAGE</u>
C-49	TH-57 aircraft marking (high visibility)	189
C-50	BQM-74C drone marking	191
C-51	UH-1N aircraft marking (non-combat SAR)	193
C-52	SH-3D/H aircraft marking (tactical)	195
C-53	T-45A aircraft marking (high visibility)	197
C-54	UH-2D aircraft marking	199

APPENDIX D

Appendix D SPECIAL PURPOSE AIRCRAFT MARKING

<u>PARAGRAPH</u>		<u>PAGE</u>
10.	SCOPE	201
10.1	Scope	201
10.2	Use	201
20.	APPLICABLE DOCUMENTS	201
30.	DEFINITIONS	201
30.1	Definitions	201
40.	GENERAL REQUIREMENTS	201
40.1	Aircraft paint schemes	201

FIGURES

<u>FIGURE</u>		<u>PAGE</u>
D-1	C-1A aircraft marking	202
D-2	C-131 aircraft marking (executive transport)	204
D-3	CT-39E/G aircraft marking (Navy)	206
D-4	CT-39G aircraft marking (Marine)	208
D-5	T-39 aircraft marking (naval attache)	210
D-6	VH-3D presidential helicopter marking	212
D-7	C-9B aircraft marking (Navy)	214
D-8	C-9B aircraft marking (Marine)	216
D-9	C-131H aircraft marking	218
D-10	T-34B aircraft marking (high visibility)	220

MIL-STD-2161A(AS)

CONTENTS

APPENDIX F

Appendix F

NATIONAL INSIGNIAS FOR FOREIGN AIRCRAFT

<u>PARAGRAPH</u>		<u>PAGE</u>
10.	SCOPE	265
10.1	Scope	265
10.2	Use	265
20.	APPLICABLE DOCUMENTS	265
30.	DEFINITIONS	265
30.1	Definitions	265
40.	GENERAL REQUIREMENTS	265
40.1	Foreign country national insignias	265

FIGURES

<u>FIGURE</u>		<u>PAGE</u>
F-1	National insignia of Portugal (flash and numbers)	266
F-2	National insignia of Argentina	267
F-3	National insignia of Mexico (flash)	268
F-4	National insignia of Great Britain	269
F-5	National insignia of Canada (roundel) marking I	270
F-6	National insignia of Canada (flash) marking II	271
F-7	National insignia of Netherlands (roundel) marking I	272
F-8	National insignia of Netherlands (flash) marking II	273
F-9	National insignia of France (cocarde) marking I (anchor superimposed when planes are intended for French Navy)	274
F-10	National insignia of France (flash) marking II	275
F-11	National insignia of Australia (roundel) marking I	276
F-12	National insignia of Australia (flash) marking II	277
F-13	National insignia of Japan (roundel)	278
F-14	National insignia of Japan (kanji characters)	279

MIL-STD-2161A(AS)

CONTENTS

FIGURES

<u>FIGURE</u>		<u>PAGE</u>
F-15	National insignia of Uruguay (roundel).	280
F-16	National insignia of Uruguay	281
F-17	National insignia of Brazil (star) marking I	282
F-18	National insignia of Brazil (flash) marking II	283
F-19	National insignia of Federal Republic of Germany	284
F-20	National insignia of Federal Republic of Germany	285
F-21	National insignia of Italy (cocarde)	286
F-22	National insignia of New Zealand (roundel) marking I	287
F-23	National insignia of New Zealand (flash) marking II	288

MIL-STD-2161A(AS)

1. SCOPE

1.1 General. This military standard establishes the requirements for paint schemes and markings to be applied to the exterior surfaces of U S. Navy and Marine Corps aircraft, including those procured for other government agencies and foreign countries under Navy contracts, in accordance with the directive of the Chief of Naval Operations. The requirements for paint scheme and markings include size, color, and approximate locations, where applicable, as shown in illustrations. This standard also provides a mechanism to obtain approval for deviation from these requirements.

1.2 Purpose. The purpose of this document is to standardize paint schemes and application of naval insignia and markings. In addition, this standard provides procedures to obtain approval for deviations from these requirements.

1.3 Foreign government aircraft. The requirements for the insignia and markings for foreign government aircraft procured under Navy contracts shall be as shown in Appendix A, except that the U.S. national insignia shall be replaced by that of the purchasing government, and naval insignia will not be applied. Foreign insignia, and flash insignia for vertical tail surfaces or rudders, and markings are shown in Appendix F. Insignia not shown will be furnished by the Naval Air Systems Command (AIR 5164) as required. Paint schemes for foreign government aircraft are as specified by that foreign government and, as such, are not contained in this document.

1.4 Military aircraft used in research projects. The provisions of this standard are not applicable to military aircraft research projects. The color and marking schemes of such aircraft is subject to case by case approval by the Naval Air Systems Command (AIR 5164).

MIL-STD-2161A(AS)

2. APPLICABLE DOCUMENTS

2.1 Government documents.

2.1.1 Specifications and standards. The following specifications and standards form a part of this document to the extent specified herein. Unless otherwise specified, the issues of these documents are those listed in the issue of the Department of Defense Index of Specifications and Standards (DODISS) and supplement thereto, cited in the solicitation (see 6.2).

SPECIFICATIONS

FEDERAL

- | | | |
|----------|---|---|
| L-S-300 | - | Sheeting and Tape, Reflective:
Nonexposed Lens |
| TT-E-489 | - | Enamel, Alkyd, Gloss Low VOC Content |

MILITARY

- | | | |
|-------------|---|--|
| MIL-F-7179 | - | Finishes, Coatings, and Sealants for the
Protection of Aerospace Weapons Systems |
| MIL-R-7705 | - | Radomes, General Specification for |
| MIL-F-18264 | - | Finishes, Organic, Weapons System
Application and Control of |
| MIL-L-19537 | - | Lacquer, Acrylic-Nitrocellulose, Gloss
(for Aircraft Use) |
| MIL-C-22750 | - | Coating, Epoxy, VOC Compliant |
| MIL-P-23377 | - | Primer Coatings, Epoxy, Chemical and
Solvent Resistant |
| MIL-P-38477 | - | Plastic Material, Pressure-Sensitive
Adhesive, for Aircraft Identification and
Marking |
| MIL-M-43719 | - | Marking Materials and Markers, Adhesive,
Elastomeric, Pigmented, General
Specification for |
| MIL-C-83286 | - | Coating Urethane, Aliphatic, Isocyanate,
for Aerospace Applications |

MIL-STD-2161A(AS)

- MIL-C-83413/9 - Connectors and Assemblies, Electrical, Aircraft Grounding: Decalomania for Grounding Receptacle Identification, Decal
- MIL-C-85285 - Coating, Polyurethane, High-Solids
- MIL-P-85582 - Primer Coatings: Epoxy, Waterborne

STANDARDS

FEDERAL

- FED-STD-595 - Colors Used in Government Procurement

MILITARY

- MIL-STD-100 - Engineering Drawing Practices
- MIL-STD-130 - Identification Marking of U.S. Military Property
- MIL-STD-970 - Standards and Specifications, Order of Preference for the Selection of
- MIL-STD-1247 - Markings, Functions and Hazard Designations of Hose, Pipe, and Tube Lines for Aircraft, Missile and Space Systems
- MS29525 - Cap, Pressure Fuel Servicing, Nominal 2-1/2 Inch Diameter Flush Type
- MS90327 - Aircraft Markings, Access Numbering System

AIR FORCE - NAVY AERONAUTICAL

- AN 815 - Union - Flared Tube
- AN 6207 - Valve - 1500 PSI Hydraulic Check

(Unless otherwise indicated, copies of federal and military specifications, standards, and handbooks are available from the Standardization Documents Order Desk, Building 4D, 700 Robbins Avenue, Philadelphia, PA 19111-5094.)

2.1.2 Other Government publications. The following other Government publications form a part of this standard to the extent specified herein. Unless otherwise specified, the issue shall be those in effect on the date of the solicitation.

MIL-STD-2161A(AS)

PUBLICATIONS

NORTH ATLANTIC TREATY ORGANIZATION (NATO)

STANAG 3104 - Identification of Aircraft and
Missile Pipe Lines and Electrical
Conduits

(Unless otherwise indicated, copies of federal and military specifications, standards, and handbooks are available from the Standardization Documents Order Desk, Building 4D, 700 Robbins Avenue, Philadelphia, PA 19111-5094.)

2.2 Order of precedence. In the event of a conflict between the text of this specification and the references cited herein (except for related associated detail specifications, specification sheets or MS standards), the text of this document shall take precedence. Nothing in this document, however, supersedes applicable laws and regulations unless a specific exemption has been obtained.

MIL-STD-2161A(AS)

3. DEFINITIONS

3.1 Tactical paint scheme. A color scheme to reduce visual detection comprised of shades of flat gray with exterior markings in a contrasting shade of gray.

3.2 Land camouflage paint scheme. A color scheme which blends into land backgrounds which is comprised of flat green, black and gray colors with exterior markings applied in a contrasting color.

MIL-STD-2161A(AS)

4. GENERAL REQUIREMENTS

4.1 Paint schemes and insignia markings. Contractors and all U.S. Navy and Marine Corps activities (including unit level maintenance activities) shall apply all insignia and markings (including identification plates for the aircraft and major assemblies, and warning and instruction markings) in accordance with this standard. The following markings are normally applied by unit level activities, but may be applied by Naval Aviation Depots and contractors, when specified by the Program Managers or Type Commanders.

Unit identifier
 Unit aircraft numbers
 Station or unit name
 Naval aviation insignia
 Radio call markings

4.2 Material.

4.2.1 Finishes. Unless otherwise specified by the Program Manager or Type Commander of a specific aircraft, all U.S. Navy and Marine Corp aircraft shall be finished in accordance with MIL-F-7179. The standard primer coating shall be MIL-P-23377 or MIL-P-85582. Type II of both MIL-P-23377 and MIL-P-85582 is for use when low infrared (IR) reflective pigments are required. The standard topcoat shall be MIL-C-83286 or MIL-C-85285.

4.2.2 Compatibility. The coating material for insignias and markings shall be the same material or material compatible with the finish on the surface to be marked.

4.2.3 Applicable limitation. Paint or other markings shall not be applied to aircraft or weapon systems when such application interferes with launching, operation, thermal reactance, reflection, or aerodynamics.

4.2.4 Metal marking instruments. Sharp-pointed metal marking instruments shall not be used in the layout of insignia or other markings on aircraft or weapon systems.

4.2.5 External finish identification. On all aircraft receiving paint finish coatings on the exterior surfaces (ie., wing, or section, if painted in sections, fuselage, fixed and movable control surfaces, land gear, or engine cowlings), their shall be an identification of the finish system consisting of a circular patch (2 1/2 to 4 inch (in.)) (63.5 to 102 millimeters (mm) in diameter). The identification patch shall be located on the starboard side of the fuselage, under or over the horizontal stabilizer, and contain the following information:

MIL-STD-2161A(AS)

- a. Contractor or overhaul activity and location.
- b. Month, day and year of completion of paint application.
- c. Identification by military specification number of all paint coating applied to the exterior of the aircraft.

Lettering shall be a minimum of 1/2 inch (12.7mm) in height. Stencils or approved decals may be used for this identification. Item c, above, may be stenciled on immediately below or alongside a circular patch containing only items a and b. Appendix B, figure B-10, is a sample of this identification.

4.2.5.1 Record of finish application. Complete information concerning the coating used, identified by the applicable military specification, the preparation of the area to be coated, and the touch-up or replacement procedure for the material used shall be included in the applicable aircraft structural repair instruction(s). A note shall be stenciled on the interior of the nose wheel well door, indicating the last major paint finish (see 4.2.5). For those aircraft that have fixed landing gear, the marking shall be applied on the fuselage under the right horizontal stabilizer for fixed wing aircraft and on the tail boom for helicopters.

Note: For paint materials not included in a military specification, identification of material and name of manufacturer shall be listed.

4.3 Drawings. On all production contracts, the contractor shall submit for approval to Commander, Naval Air Systems Command (AIR 5164), via the contracting officer, three-dimensional drawings, and any revisions thereof, showing paint schemes and the size and location of the insignia and markings (except those markings specified in paragraph 4.1) prescribed in this standard. A copy shall be sent to Commanding Officer, Naval Air Warfare Center Aircraft Division Lakehurst, Systems Requirement Department (Code SR3), Lakehurst, New Jersey, 08733-5100, for information. Naval Aviation Depots shall submit for approval to Commander, Naval Air Systems Command (AIR 5164), copies of all paint scheme and marking drawings and revisions thereto.

4.4 Service requirements. Naval Aviation Activities, including Naval Aviation Depots and unit level maintenance activities, shall apply other markings, which are not required to be applied by the contractor. In addition, markings duplicating those specified herein, may be applied to other areas of the aircraft at the discretion of cognizant commands as operational aids, provided such markings are not prohibited by tactical paint scheme requirements or other considerations, and do not conflict with the markings prescribed herein in the area selected.

4.5 Foreign government aircraft. The exterior colors and markings of aircraft procured for foreign governments under naval contracts shall be as specified by that foreign government.

MIL-STD-2161A(AS)

4.6 Color and style of marking materials and paint schemes. The color and gloss of materials shall be as specified in 4.6.1. For nontactical paint scheme aircraft, the marking materials and decalcomanias used shall be glossy, unless otherwise specified by the Program Manager or Type Commander. For aircraft with tactical paint schemes or land camouflage schemes, the marking materials and decalcomanias used shall be nonspecular in areas coated with nonspecular finish.

4.6.1 Color standard. Only colors listed in FED-STD-595 shall be used on U.S. Navy and Marine Corps aircraft. The list below includes, but is not limited to, colors used on naval weapons systems.

TABLE I. Color standard.

Color	Gloss	Lusterless (camouflage)
White	17925	37925
Black	17038	37038
Blue	15044	35044 35237
Red	11136	31136
Orange	12197	28915
Yellow	13538	33538
Green	14097	34095 34097 34064
Gray	16081 16440	36081 36440 36320 36375 36495 36099

MIL-STD-2161A(AS)

5. DETAILED REQUIREMENTS

5.1 Aircraft paint schemes. Paint schemes for utility, cargo, trainer, search and rescue (SAR), fighter and attack aircraft shall be in accordance with Appendix C. Paint schemes for special purpose aircraft, including the presidential helicopter shall be in accordance with Appendix D; tactical paint schemes shall be in accordance with Appendix E.

5.1.1 High visibility color configurations. Aircraft in the training command (excluding reserve training), target control, SAR (excluding helicopters in combat SAR configuration) shall have a high visibility paint scheme in accordance with Appendix C. Additionally, target aircraft, drones, and test and evaluation aircraft shall have a high visibility paint scheme. Transparent areas, antiglare areas, hinges, openings, screens, and any part of the exhaust trail shall not be topcoated with a high visibility coating. Request for utilization of high visibility color configuration on other types of aircraft shall be submitted for approval to the Naval Air Systems Command (AIR 5164) via the Program Manager or Type Commander.

5.1.1.1 Application and color patterns. General principles applicable to the placement of high visibility paint schemes are as follows:

- a. Wing tip markings are placed on the top and bottom of the wings, extending inboard on the wings about one-third of the length of each wing, but extending inboard no less than 4 feet or more than 8 feet. Unless specific dimensions are given, the strip shall terminate at a natural break in the wing contour. Horizontal control surfaces are not to be coated with high visibility paint.
- b. The entire vertical tail section except control surfaces shall be painted to the zone where the vertical stabilizer flares into the fuselage.
- c. All aircraft, except transports, shall be painted on the bottom and sides on the front portion of the fuselage starting from the radome, if any, and extending aft and terminating at a line perpendicular to the forward edge of the front canopy. For transports, the bottom and the sides on the front portion of the fuselage shall be painted, starting from aft of the radome and extending aft 12 feet, or aft to a line perpendicular to the most forward portion of the engines, whichever distance is less. The customary insignia, markings, solar reflecting finish, antiglare, walkway materials, rain erosion resistant finish, deicer boots, exhaust trail finish, etc., shall retain the original color and these areas shall not be overpainted.

MIL-STD-2161A(AS)

- d. Wing tip tanks on aircraft finished with the high visibility paint scheme shall be painted international orange, FED-STD-595, color number 12197, except when these tanks are part of the areas where antiglare or polishing is required.
- e. High visibility paint schemes shall not be applied to any transparent or translucent plastic, metal frames or fittings on windows nor to painted nose sections having an area of less than 2ft².

5.1.2 Arctic paint scheme. The high visibility paint scheme may be advantageous for assisting in spotting downed aircraft against a snow background. Use of this paint scheme, however, shall be in accordance with 5.1.1. Fuselage markings, such as branch of service, etc., shall not be overcoated or overlapped with the high visibility paint scheme. The national insignia on the fuselage and the wings shall not be overcoated or overlapped by the high visibility paint scheme. The national insignia, however, may be applied over the high visibility paint scheme and shall not be altered in its size or location. The remainder of the aircraft shall retain the paint scheme prescribed for the aircraft type, with the exception that upper surfaces of the fuselage shall be painted gray, FED-STD-595, color number 16081, in place of insignia white, FED-STD-595, color number 17925. On helicopters, international orange, FED-STD-595, color number 12197, shall be applied overall, with the exception of areas requiring extensive marking. These areas shall retain the basic aircraft paint scheme.

5.1.3 Tactical paint schemes. Tactical paint schemes are used for deception, reduction of initial detection range, confusion of the observers as to the identity, extent, number of aircraft, and/or reduce the probability of visual or photographic detection (in flight or on the ground). Tactical paint scheme patterns are based on optical principles that dictate certain nonreflective colors, color configurations, and color proportions. Arbitrary application of markings and color schemes, other than those prescribed in this standard, are prohibited. Tactical paint schemes are comprised of either two or three shades of gray or blue (FED-STD-595, color numbers 35237, 36320, 36375, or 36495).

5.1.3.1 Tactical paint scheme materials. The standard topcoat for the tactical paint scheme and common insignia marking is polyurethane (lusterless) coating conforming to MIL-C-83286 or MIL-C-85285. Decals may be used in lieu of paint for insignia and markings provided that they are made of a non-reflective decal material meeting the gloss and color requirements of the coating system. Decals used to apply large markings (such as the national insignia) are not permitted. The use of MIL-C-83286 or MIL-C-85285 is not required for applying aircraft unit peculiar markings.

5.1.3.2 Tactical paint scheme patterns. Approved tactical paint scheme patterns shall be in accordance with Appendix E.

MIL-STD-2161A(AS)

5.1.3.2.1 Aircraft surfaces. The tactical paint scheme patterns shall be in accordance with the specific aircraft illustrations of Appendix E. These illustrations, however, are intended only as guides. Minor variations in pattern are acceptable. Care shall be taken that proportion and balance of the colors are approximately as shown in the illustrations. Boundaries between colors shall be irregular as illustrated and fade into each other with no sharp lines of demarcation. A 6 inch blend line shall be used at all color boundaries.

5.1.3.2.2 Bottom surfaces. Most tactical paint schemes use a single color on the underside of the fuselage, wings, horizontal stabilizer, and control surfaces. The color on the underside of the aircraft shall be brought up the sides of the fuselage to give the approximate side view appearance in accordance with the application illustration of Appendix E. The transition from the underside color to the upper surface pattern shall be an irregular, indistinct, countershaded, blend area. A sharp line and any regular repeating pattern (such as a scallop) will raise the risk of detection and compromise the overall effect. On low-wing aircraft, the color on the bottom of the fuselage shall be brought into the wing root to meet the color under the wing.

5.1.4 Paint scheme for drones. Drones shall have the upper surfaces (except fuselage), vertical stabilizer, and rudder, painted insignia white, FED-STD-595, color number 17925. The entire fuselage shall be painted international orange, FED-STD-595, color number 12197. The bottom of all aerodynamic surfaces shall be painted insignia red, FED-STD-595, color number 11136. See Appendix C, figure C-50 for an example of the drone paint scheme.

5.1.5 Paint scheme for target aircraft. All exterior surfaces of target aircraft shall be painted fluorescent yellow-orange, FED-STD-595, color number 28915, with the exception of the QF-4 and QF-86, which shall have only the wing tips and vertical tail painted fluorescent yellow-orange, FED-STD-595, color number 28915.

5.1.6 Solar heat reflection. With the exception of where tactical paint schemes are employed, the upper surfaces of the fuselage of all land-based cargo, transport, and utility planes shall be painted insignia white, FED-STD-595, color number 17925. The white color shall begin at the top, forward edge of the pilot's enclosure, extending aft to include the vertical stabilizer and elevator, and extending down each side of the fuselage to the bottom of the windows, in accordance with Appendix C, figures C-8, C-11, C-12, D-1, D-7, D-8, D-9. Aircraft used in a transport or staff capacity may employ stripes below the white area and a chevron on the nacelles for decorative purposes.

5.1.7 Antiglare. On all pilot-operated aircraft, nonspecular (lusterless) paint shall be employed on all airframe surfaces which may produce glare in the pilot's or copilot's eyes, or induce eye strain due to excessive brightness. These areas shall be painted nonspecular (lusterless) black, FED-STD-595, color number 37038, with the exception of aircraft painted with tactical paint schemes. Aircraft painted with tactical paint

MIL-STD-2161A(AS)

schemes shall use nonspecular gray, FED-STD-595, color number 36320, or blue, FED-STD-595 color number 35237.

5.1.8 Glass fiber reinforced plastic assemblies. The color of assemblies fabricated of glass-fiber reinforced plastic, (such as radomes, radio antenna housings, noses, fairings, wing tips, and intake ducts), for which rain-erosion-protective finishes are required, shall match the color of adjacent surfaces, with the exception of the frontal areas. These frontal areas shall be in the natural color of the rain erosion protective finish and shall not be overcoated for color matching purposes. The extent and location of the frontal areas thus finished shall be in accordance with MIL-R-7705. For aircraft with the tactical paint scheme where plastic assemblies require rain erosion coatings, the rain erosion coating shall be applied in the same color as adjacent areas.

5.1.9 Landing gear.

5.1.9.1 Fixed landing gear. Fixed landing gear shall be painted to match the prescribed color scheme of the particular aircraft.

5.1.9.2 Retractable landing gear. Retractable landing gear, wheel well areas, wheel assemblies, inner surfaces of landing gear well covers, hydroskis (including the strut and trunnion doors) and nose gear doors (auxiliary, including the strut door), etc., shall be colored insignia white, FED-STD-595, color number 17925, except for Marine Corps helicopters, where the color shall be field green, FED-STD-595, color number 34095, or black, FED-STD-595 color number 37038. For tactical paint schemes, the color shall be either black, FED-STD-595, color number 37038 or the same gray used on the aircraft. The edges of the landing gear door shall be painted insignia red, FED-STD-595, color number 11136, without overcoating the white. The outer surfaces of the well covers shall be painted to match the prescribed color scheme of the aircraft.

5.1.10 Speed brakes, wing flaps, etc. Interior surfaces of speed brakes and wing flaps shall be colored insignia red, FED-STD-595, color number 11136. Exterior surfaces of speed brakes and wing flaps shall be colored to match the prescribed color scheme of the aircraft. Wing flap areas which are covered by the wing when they are in the retracted position shall be colored insignia red, FED-STD-595, color number 11136. Conformance to these requirements will be determined on a case-by-case basis by the Program Manager in conjunction with the Naval Air Systems Command (AIR 5164). In case of hostility, fleet commanders have the authority to overpaint these red areas for tactical advantage.

5.1.11 Wing leading edge slats. The interior (lower) surface and inboard end of wing leading edge slats, and the wing area covered by the slat, when in a fully retracted position, shall be colored insignia red, FED-STD-595, color number 11136, with the exceptions of new aircraft to be delivered with a tactical paint scheme. On these new aircraft, the interior surface covering color shall be determined by the Program Manager in

MIL-STD-2161A(AS)

conjunction with the Naval Air Systems Command (AIR 5164). Exterior surfaces of wing leading edge slats shall be colored to match the required color scheme of the aircraft (see the applicable figure in Appendices C, D, or E).

5.1.12 Walkways and steps. Where anti-skid material is applied, the color shall be as follows: for conventionally painted aircraft, the color shall be gray, FED-STD-595, color number 36231, or black, FED-STD-595, color number 37038. For aircraft with land camouflage schemes, the color shall be black, FED-STD-595, color number 37038, or field green, FED-STD-595, color number 34095. For aircraft with tactical paint schemes, the color shall match the color of adjacent areas.

5.1.13 External stores (including ordnance). External fuel tanks, pylons, rocket launchers, missiles, pods, and other mounted equipment shall be colored to conform with the aircraft paint scheme. For tactical paint schemes, gray, FED-STD-595, color number 36375, shall be used, with the exception of external stores peculiar to the A-4 and SH-60 aircraft. For these items, the color shall be gray, FED-STD-595, color number 36495. Land camouflage paint schemes (excluding AV-8 aircraft) shall be green, FED-STD-595, color number 34095, and all other paint schemes will use FED-STD-595, color number 17925. External stores peculiar to the AV-8 shall be painted gray, FED-STD-595, color number 36440. Stores used on multiple aircraft with different color schemes will be painted to match the primary user. If temperature problems occur, the use of a lighter shade of gray is acceptable upon approval of the Naval Air Systems Command (AIR 5164). Safety color coded markings shall be implemented as specified in other directives.

5.1.14 Radomes, antennae, and antennae covers. Blade type antennae, antenna mast, antennae covers and radomes shall be painted to match the color of adjacent areas except as noted in paragraph 5.1.8.

5.1.15 Helicopter blades, hubs, transmissions and rotor mechanisms.

5.1.15.1 Rotor blades. Main and tail rotor blades shall be painted black, FED-STD-595, color number 37038, except when the tactical paint scheme is utilized. When the tactical paint scheme is utilized, the color of the rotor blades shall be black, FED-STD-595, color number 37038 or gray. The gray color will depend on the aircraft model. Marking of the main and tail rotor blades shall be in accordance with 5.2.2.10.3 and 5.2.2.10.3.5.

5.1.15.2 Hubs of helicopters. Helicopter hubs shall be painted black, FED-STD-595, color number 37038, except aircraft painted with the tactical paint scheme. For aircraft painted with tactical paint scheme, the color of the hubs shall match the tactical paint scheme. Overpainting of installed hubs shall be accomplished in accordance with MIL-F-18264.

5.1.15.3 Transmission and rotor mechanisms of helicopters. Helicopter transmissions and rotor mechanisms, other than blades and hubs, shall be painted black, FED-STD-595, color number 37038, with the exception of aircraft painted with a tactical paint scheme. For aircraft with a tactical paint

MIL-STD-2161A(AS)

scheme, the color of the transmission and rotomechanisms shall match the tactical paint scheme. Overpainting of the items shall be accomplished in accordance with MIL-F-18264.

Note: When the same model/series aircraft is used in both the Marine Corps and the Navy and each service requires a different paint scheme, the assemblies (including blades) shall be painted black, FED-STD-595, color number 37038, or gray on all the aircraft. The gray color number will depend on the aircraft model. The decision on which color to use will be based on which service has the most aircraft of this model/series.

5.1.16 Jet air intake ducts. The color of the adjacent aircraft exterior shall be carried around the lip of the duct and into the duct approximately 6 inches (except for the chevrons). All remaining interior surfaces of the duct shall be painted insignia white, FED-STD-595, color number 17925.

5.1.17 Propeller assemblies.

5.1.17.1 Blades. Blades shall be painted black, FED-STD-595, color number 37038, with the exception of aircraft with a tactical paint scheme. For aircraft with a tactical paint scheme the color of the blades shall match the tactical paint scheme. Markings shall be as specified in 5.2.2.10.3 and 5.2.2.10.3.5.

5.1.17.2 Spinners. Spinners shall be painted black, FED-STD-595, color number 37038, with the exception of aircraft with the tactical paint scheme. For aircraft with a tactical paint scheme, the color of the spinners shall match the tactical paint scheme.

5.1.17.3 Hubs and domes. Hubs and domes shall be painted black, FED-STD-595, color number 37038, with the exception of aircraft with tactical paint schemes. For aircraft with a tactical paint scheme, the color of hubs and domes shall match the tactical paint scheme.

5.1.18 Engine cowling interiors. The interior of engine cowlings shall be painted gray, FED-STD-595, color number 16440.

5.2 Aircraft exterior markings. Certain provisions of this military standard are subject to international standardization agreements and must not be changed, except under emergency conditions, without prior coordination with North Atlantic Treaty Organization (NATO) (STANAG 3104). Unless otherwise specified, the height of all characters shall be chosen from the following sizes: 12, 16, 20, 24, 30 or 36 inches.

5.2.1 Identification marking. Identification markings for all U.S. Navy and Marine Corps aircraft, with the exceptions of 5.2.1.1.1 through 5.2.1.1.7, shall be in accordance with 5.2.2 for mandatory markings, 5.2.6 for optional markings, and herein. Guidance is provided in 5.2.3 for markings applied to

MIL-STD-2161A(AS)

aircraft with the tactical and land camouflage paint schemes.

5.2.1.1 Letter and numeral (character) construction. All letters and numerals (characters) shall be constructed in a modified vertical block form (see Appendix A, figure A-4). All characters shall be uniform in shape and size. The width of the characters, excluding the dash (-) and the letters G, A, M and W, shall be 75 percent of the height of the character. The dash shall be constructed in accordance with Appendix A, figure A-4. The width of letters A and M shall be 92 percent of its height. The width of the letter W shall be 108 percent of its height. The width of the letter G, with the exception of its overhang on its right side, shall be 75 percent of its height. All overhangs on letters C, G, S and numerals 2, 3, 4, and 9 shall be 1/12 of the character's height. The height of characters shall be a minimum of one inch. In areas where this is not possible due to space limitation, the height of the characters may be reduced to 1/2 inch. Decalcomania conforming to MIL-P-38477 or MIL-M-43719 may be used for application of markings. Only small maintenance marking may be applied by decal to supersonic aircraft and in areas where it may become dislodged and cause foreign object damage (FOD). Decals used shall perform as well or better than the standard topcoat in appearance and durability. Decals shall not be applied where they may be deleterious to the surface to which they are applied. Decals shall not be applied over brazier head rivets.

5.2.1.1.1 Helicopters. The typical identification markings for helicopters shall be in accordance with applicable figures of Appendix C.

5.2.1.1.2 Research aircraft. The markings of military aircraft used for research projects are subject to Naval Air Systems Command (AIR 5164) approval in each case.

5.2.1.1.3 Experimental aircraft. Experimental aircraft shall be marked as specified in Appendix C, insofar as practicable. In addition, the marking "U.S. NAVY" shall be applied on the upper surface of the right wing and on the bottom surface of the left wing, in a similar location to the national insignia on the opposite wing. The height of the letters shall be the largest possible size that can be accommodated on the aircraft, selected from 5.2.

5.2.1.1.4 Target aircraft and guided missiles. Target aircraft and SS-type guided missiles with wings (excluding stabilizing fins) shall have the national insignia applied, in accordance with Appendix A, and shall be marked as specified in Appendix C insofar as is practicable. The size of the letters and numerals shall be as specified in Appendix C. If there are space limitations, the size may be reduced proportionately. For all other types of guided missiles, only the serial number and model designation, if applicable, shall be applied.

MIL-STD-2161A(AS)

5.2.1.1.5 Target aircraft. Target aircraft shall have the word "Target" applied along the port side of the forward and aft sections of the fuselage, the starboard side of the midsection of the fuselage, the top side of each wing assembly, inboard from the wing tips, the top side of each horizontal tail surface (as applicable), inboard from the tips, and the starboard side of each vertical tail surface.

5.2.1.1.6 Test and evaluation (T&E) aircraft. Aircraft assigned to T&E activities shall comply with the provisions of this standard to the extent that is practical. Deviations to meet specific test objectives or safety of flight require Naval Air Systems Command (AIR 5164) approval.

5.2.2 Mandatory markings for U.S. Navy and Marine Corps aircraft. The markings and insignia contained in this section will be applied to all U.S. Navy and Marine Corps aircraft, as specified herein. Paragraph 5.2.3 contains special instructions concerning markings and insignia for tactical and land camouflage paint schemes. Appendix A reflects specific instructions, dimensions, etc., for the proper application of these markings and insignia. Table II lists the standard markings and insignia for all aircraft.

5.2.2.1 Changes. Dimensioned drawings, showing the size and location of the insignia and markings applied to various types of aircraft, are prepared in accordance with applicable Naval Air Systems Command (AIR 5164) instructions. Any changes proposed to these insignia and markings must be coordinated with the Naval Aviation Depot (NADep) that prepared the service drawing and the Naval Air Warfare Center Aircraft Division, Systems Requirements Department (Code SR3) Lakehurst, NJ, 08733-5100. Approval must also be from the Naval Air Systems Command (AIR 5164). The views shown in the Appendices are conventionalized. Minor changes may be necessary due to space limitations or configuration to adapt the markings to the specific model of aircraft, including those shown herein. Any changes made shall not preclude the quick identification and recognition of the aircraft.

MIL-STD-2161A(AS)

TABLE II. Mandatory markings for U.S. Navy and Marine Corps aircraft.

Item	General location	
	Fixed wing	Rotary wing
National star	Wing and fuselage	Fuselage
Branch of service	Wing and fuselage	Fuselage
Model designation	Fuselage	Fuselage
Airplane serial number (BUNO)	Fuselage	Fuselage
Unit aircraft number	Fuselage	Fuselage
Squadron designation	Fuselage	Fuselage
Unit identifier	Vertical stabilizer	Aft pylon or upper tail boom
Station or unit name	Vertical stabilizer	As specified
Call numbers	Vertical stabilizer	Aft pylon or upper tail boom
Warning markings	As specified	As specified

MIL-STD-2161A(AS)

5.2.2.2 Application. All identifying information, except the national insignia, on the under surface of the wing shall be so applied so that it can be read from left to right when standing in front of, and facing, the aircraft. On swept-back and variable sweep wings, all letters and numerals shall be applied symmetrically along the 50 percent constant chord line, as is required for application of the national insignia. Insofar as is practicable, all letters and numerals shall be positioned on the fuselage and vertical tail surface so as to be perpendicular to the fuselage reference line.

5.2.2.3 National star insignia. The national star insignia will be applied to all aircraft as delineated in Appendix A, figure A-1.

5.2.2.4 Branch of service marking. The branch of service marking shall be applied to all aircraft. The style, positions and size of this marking on the aircraft shall be in accordance with 5.2.2.4.1 and 5.2.2.4.2.

5.2.2.4.1 Branch of service marking - style. On aircraft operated by the U.S. Navy and Naval Reserve, the branch of service marking shall consist of "NAVY" or, on cargo/transport aircraft, "UNITED STATES NAVY", as specified in Appendices C, D, and E. On aircraft operated by the U.S. Marine Corps and Marine Corps Air Reserve, the branch of service marking shall consist of the word "MARINES". On aircraft operated jointly by the U.S. Navy and Marine Corps, and/or their Reserve components, the branch of service marking shall consist of "NAVY".

5.2.2.4.2 Branch of service marking - size and location. The size of the lettering of the branch of service marking shall be as large as possible on the aircraft. The height of the letters shall be selected from 5.2. Special sizing instructions for tactical and camouflage paint schemes are contained in 5.2.3, and Appendix A, figure A-15, bottom entry provides an example of the branch of service marking. The location of the branch of service marking shall be both sides of the fuselage, just forward of the empennage (aircraft tail).

5.2.2.5 Model designation and bureau airplane serial number (BUNO). BUNO shall be applied just below the model designation, in accordance with Appendices C, D, and E.

5.2.2.5.1 Model designation and BUNO - location. BUNO shall be centrally located on both sides of the fuselage under the horizontal stabilizer in the position shown in Appendices C, D, and E. For transport (VR) aircraft having twin booms, these markings shall be centrally located on the outboard side of each main boom, between the insignia and the horizontal stabilizer. The BUNO shall be symmetrically located 2 inches below the model designation.

5.2.2.5.2 Size. Model designation numerals and letters shall be 2 inches high and BUNO shall be 4 inches high.

MIL-STD-2161A(AS)

5.2.2.6 Unit aircraft number. The unit aircraft number shall consist of numbers only, to designate the number of the airplane within the unit. Where CNO directives specify, the use of the last three digits of the BUNO shall comprise the unit aircraft number. CNO directives permit tactical aircraft to be marked with the last four digits of the BUNO to differentiate it from another aircraft having the same last three digits.

5.2.2.6.1 Location. The unit aircraft number shall be located on the bow of the aircraft on both sides of the fuselage.

5.2.2.6.2 Size. Unit aircraft numbers shall be a minimum of 12 inches high and shall be the largest possible of the sizes specified in 5.2, not to exceed 50 percent of the height of the projection of the fuselage side at the point of application.

5.2.2.7 Unit identifier. The unit identifier shall consist of letters only, to designate the squadron or group of the airplane (letters are assigned in accordance with CNO directives).

5.2.2.7.1 Location. The unit identifier shall be applied to both sides of the vertical tail surfaces above the horizontal stabilizer, centered on the vertical surfaces. On multiple tail surfaces the marking shall appear on the outboard sides only. An effort shall be made to avoid applying the unit identifier on rudders finished in white, FED-STD-595, color number 17925; however, the specified height of the letters must be maintained.

5.2.2.7.2 Size. Letters shall be a minimum of 10 inches high and shall be the largest possible specified in 5.2. In case of double letters, the width of each letter may be reduced to accommodate the letters to the shape of the tail surface, retaining maximum clarity, visibility, and symmetry. The size of letters for tactical and land camouflage paint schemes is as specified in 5.2.3.

5.2.2.8 Station or unit name. On shore-based aircraft, where no unit identifiers are assigned, this marking shall consist of the name of the air station, e.g., Alameda, Corpus Christi, etc., or abbreviation of the unit's title, e.g., AIRON-81, employed in lieu of the unit identifier. If the station name is marked on the vertical tail surfaces, it shall not be applied on the fuselage.

5.2.2.8.1 Location. The station or unit name shall be applied on the vertical tail surfaces in the locations specified in Appendix C for the unit identifier.

5.2.2.8.2 Size. The size of the letters shall be such that the station or unit name can be accommodated on the vertical tail surfaces in the specified location. If necessary due to space limitations, the station or unit name may be divided to occupy two lines. If two lines are used for station names, the dash shall be omitted and the letters on the second line shall be centered below those on the top line.

MIL-STD-2161A(AS)

5.2.2.9 Call numbers. Each aircraft, except primary trainers not having radio equipment, shall have a call number painted on each side of the vertical stabilizer surface or on each outboard side, as applicable. The numbers or designators shall be discernible from a distance of 50 yards. The number height should be no less than 12 inches; however, if space does not permit a height of 12 inches, the height shall be as large as possible. The call numbers shall consist of at least the last four numbers of the bureau number. Arabic numbers shall be used when applying call numbers.

5.2.2.9.1 Location. The call numbers shall be applied to both sides of the vertical stabilizer and rudder assembly, or to each outboard side, as applicable. On rotary wing aircraft, or if space limitations do not permit on other aircraft, these numbers shall be applied aft along the fuselage, or aft along each side of the tail boom, as applicable.

5.2.2.9.2 Size. The height of the numbers shall be the largest size possible of the sizes listed in 5.2. Under no circumstances shall the height of the characters be less than 12 inches.

5.2.2.10 Mandatory safety markings. Mandatory standard safety markings are as follows. For tactical and land camouflage paint schemes, refer to 5.2.3 for special instructions.

5.2.2.10.1 Jet engine intake warning chevrons and signs. The areas of the leading edge of the wing, the fuselage, or the nacelle or pod, or combination thereof, which are adjacent to the sides of a jet engine intake shall be marked with warning chevrons and signs, as specified in the following subparagraphs.

5.2.2.10.1.1 Application. The chevrons shall be applied such that the ends of their outer sides contact the edge of the intake at points which are three-quarters of the diameter, or three-quarters of the short axis, of the intake port. The outer points of the chevrons shall be located at a distance of 4 feet outboard along the leading edge of the wing, or forward or aft, if applied on the fuselage, or aft, if applied on the nacelle or pod, from the center of the intake. The chevrons shall be 3 inches in width and shall be marked in insignia red, FED-STD-595, color number 11136, with the exception of tactical paint scheme aircraft. Superimposed on one side of a chevron shall be the word "Jet" and on the other side the word "Intake" in insignia white, FED-STD-595, color number 17925 (see Appendix A, figure A-8). The letters shall be 2 inches in height. The word "Danger" (with an arrow directed at the point of the chevron, see Appendix A, figure A-8) shall be applied along the leading edge of the wing, or on the fuselage, nacelle, or pod, as applicable. The letters and arrows shall be insignia red, FED-STD-595, color number 11136, and shall be superimposed on a stripe of insignia white, FED-STD-595, color number 17925, 3 inches in width. The height of the letters and length of the arrows shall be 2 inches. Aircraft painted with tactical or land camouflage paint schemes shall comply with the color requirements of 5.2.3.

MIL-STD-2161A(AS)

5.2.2.10.1.2 Variations. The dimensions specified above shall be adhered to in general. They may be varied, and the word "Danger" (with the arrows pointing to the edge of the intake) may be applied within the V of the chevrons if there are space limitations or other considerations. The general outline and appearance of the warning chevrons shall conform to Appendix A, figure A-8.

5.2.2.10.2 Jet engine blast warning. The areas of the fuselage, nacelle or pod, or combination thereof, which are adjacent to the sides of a jet engine exhaust shall be marked with the words "Beware of blast" as shown in Appendix A, figure A-8.

5.2.2.10.3 Propeller, rotor, and turbine safety markings. Application of safety markings to statically balanced propellers and rotor blades shall be limited to new blades or to overhauled blades, in accordance with 5.2.2.10.3.1.3. Lusterless (camouflage) colors only shall be used for propellers and rotor blade identification danger zone marking, or preservation and antiglare purposes, unless otherwise noted herein. Before topcoat and markings are applied, all surfaces shall be thoroughly cleaned and prepared with primer coating. Letters and numerals shall be 1 inch in height. If there are space limitations, letters and numerals may be reduced in height to 1/2 inch. For tactical and land camouflage paint schemes, the use of identification stripes on rotor blades is dependent upon whether they can be overpainted by field units. If the provisions of paragraph 5.2.2.10.3.1.3 can be met, identification stripes shall be used. On all other rotor blades, identification stripes shall be eliminated.

5.2.2.10.3.1 Main rotor blades.

5.2.2.10.3.1.1 Matched sets. For matched sets of main rotor blades, individual identification stripe shall be painted on both side of the blade from the tip to 2 inches from the tip. This stripe shall be insignia white, FED-STD-595, color number 17925, for one blade, insignia red, FED-STD-595, color number 11136, for the second blade, and light green, FED-STD-595, color number 14187, for the third blade. In addition, orange-yellow, FED-STD-595, color number 33538, warning stripes shall be applied inboard of the 2 inch stripe on both of the blades, and shall extend from the line 2 inches from the tip to a line 8 inches from the tip. FOR TACTICAL AND LAND CAMOUFLAGE PAINT SCHEMES, 5.2.2.10.3 SHALL APPLY.

5.2.2.10.3.1.2 Unmatched sets. For unmatched sets of main rotor blades, orange-yellow warning stripes, FED-STD-595, color number 33538, shall be applied to both sides of the blades from the tip to 6 inches from the tip. FOR TACTICAL AND LAND CAMOUFLAGE PAINT SCHEMES, 5.2.2.10.3 SHALL APPLY.

5.2.2.10.3.1.3 Static balance - preservation and maintenance. Paint or other marking, when applied to propellers, rotors, or statically balanced control surfaces for antiglare or protective purposes, shall be applied only by the manufacturer or an authorized facility, except when authorized by the

MIL-STD-2161A(AS)

Type Commanders. Between overhauls, when required, marking and finishes may be retained by a light maintenance touch-up. Touch-up shall be applied to all surfaces in proportionate amounts for retention of proper balance.

5.2.2.10.3.1.4 Classification numbers. Classification numbers shall be stenciled on the main rotor blades of all helicopters by any facility authorized to balance or alter the blade. These numbers shall consist of three parts as follows:

- a. The first shall be the weight in pounds of the blade, expressed in decimal form.
- b. The second shall be the distance in inches from the center of rotation to the center of gravity of the blade.
- c. The third shall be the distance in percent mean aerodynamic chord (MAC) from the leading edge of the blade to the center of gravity of the blade clockwise (Example 57.2-75.5-32.4, when the blade has a weight of 57.2 pounds with the center of gravity 75.5 inches from the center of rotation and with the chordwise center of gravity at 32.4 percent MAC).

Stenciling, 1/2 inch to 1 inch in height, shall be accomplished with a paint that contrasts well with the color of the blade. The preceding information shall be marked on the flat surface on the ground side of each blade at the inboard or butt end of the main rotor blade.

5.2.2.10.3.2 Tail rotor blades. Tail rotor blades shall be finished as shown in Appendix A, figure A-5, starting from the tip and on both sides of the blade, as follows:

- a. A 6 inch wide band of insignia red, FED-STD-595, color number 11136.
- b. A 6 inch wide band of insignia white, FED-STD-595, color number 17925.
- c. A 6 inch wide band of insignia red, FED-STD-595, color number 11136.
- d. A nonspecular black band, FED-STD-595, color number 37038, to within 6 inches of the hub.
- e. A 6 inch wide band of insignia red, FED-STD-595, color number 11136.

FOR TACTICAL AND LAND CAMOUFLAGE PAINT SCHEMES, 5.2.2.10.3 SHALL APPLY.

MIL-STD-2161A(AS)

5.2.2.10.3.3 Helicopter tail boom - warning marking. For helicopters having tail rotor blade(s) revolving in the vertical plane, a warning sign shall be painted on both sides of the tail boom, as shown in Appendix A, figure A-12. This shall consist of a 33 inch wide band orange-yellow, FED-STD-595, color number 13538, band encircling the tail boom. Centrally superimposed on this band shall be applied a insignia red arrow, FED-STD-595, color number 11136, of appropriate size, with the arrow pointing aft as indicated in Appendix A, figure A-12. Above the arrow shall appear the word "Danger" and below the arrow shall appear the words "Keep Away." The letters shall be black, FED-STD-595, color number 17038, and shall be approximately 2 inches in height.

5.2.2.10.3.4 Helicopter tail rotor - guards and stabilizers. On helicopters with tail rotor guards and/or stabilizers, the tail rotor guard and/or stabilizer shall have warning markings applied to prevent ground personnel from accidentally running into these components. The markings shall consist of 2 inch wide alternating stripes of orange-yellow, FED-STD-595, color number 13538, and bright red, FED-STD-595, color number 11136.

5.2.2.10.3.5 Propeller blades - warning markings. Blades shall be painted as shown in Appendix A, figure A-6. Propeller blades on multi-engine planes shall be painted on both sides from the tip to 3 inches from the tip with insignia white, FED-STD-595, color number 17925, followed by a 6 inch strip of insignia red, FED-STD-595, color number 11136, followed by another 3 inch strip of insignia white, FED-STD-595, color number 17925. The remainder of the blade shall be colored black, FED-STD-595, color number 37038. This may be eliminated on blades where both the following conditions are met:

1. Corrosion protection is not required and
2. The blades are so situated as to produce no glare or excessive brightness in the pilot's or copilot's eyes (in cases where the blades rotate in a plane aft of the pilot's seat).

If the blades are so situated as to produce glare or excessive brightness in the pilot's or copilot's eyes, the insignia red, FED-STD-595, color number 11136, and insignia white, FED-STD-595, color number 17925, shall be replaced by red, FED-STD-595, color number 31136, and white, FED-STD-595, color number 37925, respectively, on the rear face of the blades only. Propeller blades on single engine planes shall be painted on the front side in the same manner as for multi-engine blades; the rear face, however, shall be colored black, FED-STD-595, color number 37038, with a 4 inch band of orange-yellow, FED-STD-595 color number 33538, at the tip for blades of less than 15 feet basic diameter or in a 6 inch orange-yellow, FED-STD-595, color number 33538, band for larger diameter blades.

MIL-STD-2161A(AS)

5.2.2.10.3.6 Fuselage propeller - warning stripe and signs. That area of the fuselage which is in the plane of the propeller path shall be marked with an insignia red, FED-STD-595, color number 11136, stripe 3 inches wide extending completely around the fuselage, as shown in Appendix A, figure A-9. The word "Propeller" reading vertically from top to bottom, on both sides, shall be superimposed on this stripe in insignia white, FED-STD-595, color number 17925, letters 2 inches in height, at sufficiently frequent intervals to indicate the dangerous area. The signs "Danger" and "Danger" shall be applied perpendicular to and centered with respect to the word "Propeller," one sign on each side thereof, with the arrow pointing toward the stripe. The letters and arrows shall be insignia red, FED-STD-595, color number 11136 and shall be superimposed on a stripe of white, FED-STD-595, color number 17925, 3 inches in width. The height of the letters and length of the arrows shall be 2 inches.

5.2.2.10.3.7 Bomb bay, hatch, etc., - exit warning stripe and signs. On all planes where bomb bays, hatches, or other openings exist within 6 feet of each side of the propeller disk, and which may be used as means of egress from the plane and there is danger of personnel walking into propellers after leaving such openings, warning stripes and signs shall be placed to warn personnel regarding the proximity of propellers. Those interior areas of the fuselage, bomb bay flaps, etc., which are in the plane of the propeller disk, shall be marked with insignia red, FED-STD-595, color number 11136, stripes 3 inches wide, extending on both sides from the center of the fuselage to the lowest extremity of the exit, when open. The word, "Propeller," reading vertically from top to bottom on both sides, shall be superimposed on this stripe in insignia white, FED-STD-595, color number 17925, letters 2 inches in height, at sufficiently frequent intervals to indicate the dangerous areas. The signs:

"DANGER → and "← DANGER
PROPELLER" PROPELLER"

shall be applied perpendicular to and centered with respect to the word "Propeller" one sign on each side thereof, with the arrow pointing toward the stripe. The letters and arrows shall be insignia red, FED-STD-595, color number 11136, and shall be superimposed on a stripe of insignia white, FED-STD-595, color number 17925, 3 inches in width. The height of the letters and length of the arrows shall be 2 inches.

5.2.2.10.3.8 Staggered engines. On aircraft having engines staggered in the wing, a marking similar to that described in 5.2.2.10.3.6 shall also be placed on the cowling of the next inboard engine to mark the plane of rotation of the propeller disk.

5.2.2.10.4 Arresting hooks. Arresting hooks shall be painted with gloss black, FED-STD-595, color number 17038, and insignia white, FED-STD-595, color number 17925, in alternate bands 4 inches wide, to produce maximum visibility.

MIL-STD-2161A(AS)

For tactical paint schemes, the arresting hook shall be painted in the surrounding gray/blue paint scheme. Paint shall not be applied to the arresting hook point.

5.2.2.10.4.1 Arresting hook warning marking. For aircraft having arresting hooks, a warning sign shall be painted on both sides of the fuselage Appendix A, figure A-3, and A-14 and shall be located in proximity to the hook point when in the retracted position. The marking must be clearly visible to maintenance personnel.

5.2.2.10.5 Loose and jettisonable equipment. The following loose equipment shall be marked in a contrasting color, using a stencil or other suitable marking, with the call numbers: life rafts, tool kits peculiar to the airplanes, aircraft covers (engine covers, dust covers, etc.).

5.2.2.10.6 Identification and markings of emergency escape system. All exits to be used in an emergency shall be identified by the words "Emergency Exit, Rescue, Auxiliary Exit" or other appropriate wording, followed by applicable instructions or symbols. Painted insignia, letters, and markings shall be visible in the dark. Painting shall be compatible with finishes applied to adjacent surfaces. Decals shall conform to the requirements specified herein and shall be edge-sealed with a clear finish (see Appendix A, figure A-20).

5.2.2.10.6.1 Application. All surfaces to be lettered shall be prepared to ensure good contrast between lettering and background. Standard application will be black, FED-STD-595, color number 17038, letters on an orange-yellow, FED-STD-595, color number 13538, background. In some applications, orange-yellow, FED-STD-595, color number 13538, lettering on a black, FED-STD-595, color number 17038, background will be specified. Other color combinations shall not be used without approval of the procuring activity. The background border shall extend 1/2 inch beyond the lettering. Tactical and land camouflage paint scheme markings shall be in accordance with 5.2.3.

5.2.2.10.6.2 Location. Lettering and marking of the emergency escape system shall be placed so as to be easily read.

5.2.2.10.6.3 Lettering size. All lettering identification marking shall be gothic type. Exit release signs shall have 2 inch high lettering. The lettering of instruction shall be at least 1 inch high.

5.2.2.10.6.4 Cutout area marking. Each area of the aircraft intended to be cutout for emergency rescue shall be marked with the wording "Cut here for Emergency Rescue" and corner markings at the limits of the cutout area (see Appendix A, figure A-17). The horizontal and vertical lines of the corner marking shall be 3 inches long and 1 inch wide. This marking scheme shall be applied to the interior and exterior of the aircraft at the intended cutout point. The lettering shall be a minimum of 2 inches in height.

MIL-STD-2161A(AS)

5.2.2.10.6.5 Exit control lever markings. Handles and levers used to actuate doors on hatches shall be identified by alternating orange-yellow, FED-STD-595, color number 13538, and black, FED-STD-595, color number 17038, stripes in a width ratio of 3 to 1, orange-yellow, FED-STD-595, color number 13538, to black, FED-STD-595, color number 17038. The orange-yellow, FED-STD-595, color number 13538, stripes shall be widths of 3/16 inch, 3/8 inch, or 3/4 inch; the black, FED-STD-595, color number 17038, stripes shall be corresponding widths of 1/16 inch, 1/8 inch, or 1/4 inch. Background striping shall be applied at a 45-degree angle from the vertical, rotated clockwise. Small handles and levers shall be striped with alternate colored rings with the above ratio and background. The striping shall not interfere with other types of markings. If the handles or levers are visible in the aircraft's clean flight configuration, markings of aircraft with tactical paint schemes shall be in accordance with 5.2.3.

5.2.2.10.6.6 Fire access panel marking. The fire access panel in the engine cowling shall be identified by a marking conforming to Appendix A, figure A-7. The words "Fire Panel" in red letters shall be placed inside the rectangle. Tactical and land camouflage paint scheme markings shall be in accordance with 5.2.3.

5.2.2.10.6.7 Explosive-actuated devices. Ejection seats and canopies, separable capsule escape system, or encapsulated ejection seats which are actuated explosively shall be marked at appropriate locations on the fuselage (see Appendix A, figure A-11 and A-16).

5.2.2.10.6.8 Axe and crowbar. When an axe and/or crowbar are carried aboard the aircraft, their positions shall be shown externally by the words "Axe (Crowbar) Stowed Here" in 1 inch high letters. The position of the axe and/or crowbar may be further identified by a silhouette.

5.2.2.10.6.9 Fire extinguishers. When fire extinguishers are carried aboard the aircraft and are accessible from the outside of the aircraft, their positions shall be shown by the words "Fire Extinguisher Stowed Here" and may be further identified by a silhouette of a fire extinguisher.

5.2.2.10.6.10 Asbestos gloves. When asbestos gloves are carried aboard the aircraft and are accessible from the exterior, their position shall be shown by the words "Asbestos Gloves Stowed Here" in letters 1 inch high, and may be further identified by a silhouette of gloves.

5.2.2.10.6.11 First-aid kit. When a first-aid kit is carried aboard the aircraft and is accessible from the outside through an emergency exit or access panel, a red, FED-STD-595 color number 11136, greek cross on a white, FED-STD-595, color number 17925, background shall be placed on the fuselage adjacent to this exit or panel (see Appendix A, figure A-19). Tactical and land camouflage paint scheme markings shall be in accordance with 5.2.3.

MIL-STD-2161A(AS)

5.2.2.10.6.12 Ejection seat markings. All parts of the ejection seat escape system (see Appendix A, figure A-6) shall be marked with a triangle, colored insignia red FED-STD-11136. A triangle colored insignia red, FED-STD-595, color number 11136, shall be placed over each crew entrance to indicate that the aircraft has such a system. The applicable words "Ejection Seat" or "Escape Capsule" shall be applied in 1 inch high letters under the triangle. Triangles shall be located on each side of the fuselage at approximately the midpoint of the canopy for fighter, fighter-trainer, and similar aircraft. The following warning shall be applied by paint or decal in 3/4 inch high letters, on an orange-yellow, FED-STD-595, color number 13538, background, beneath the triangles: "Warning - This aircraft contains a cartridge-actuated emergency escape system equipped with explosive charges" (see Appendix A, figure A-11 and A-16). See Appendix A for complete instructions. Tactical and land camouflage paint scheme markings shall be in accordance with 5.2.3.

5.2.2.10.6.12.1 Ejection seat markings for multiplace aircraft. If an aircraft is equipped with cartridge-actuated escape provisions other than ejection seats, at certain crew stations, along with ejection seats at other stations, the markings located on the exterior of the aircraft at each crew entrance not equipped with ejection seats shall read "Cartridge-Actuated Devices" instead of "Escape Capsule" or "Ejection Seat" under the triangle. In the event all crew members use the same entrances, both notes shall be printed under the triangle with the warning.

5.2.2.10.6.12.2 Other cartridge-actuated escape systems. For aircraft equipped with cartridge-actuated escape systems, such as hatch jettisoning systems, equipment stowage systems, etc., but no means to forcibly separate crew members from the aircraft, marking shall read "Cartridge-Actuated Devices."

5.2.2.10.6.13 Canopy release markings. External canopy release access on aircraft shall be painted orange-yellow, FED-STD-595, color number 13538. Release instructions from the outside shall be painted in black, FED-STD-595, color number 17038. A reflective placard applied near the canopy on the side of the flag opposite the canopy release shall show the location of the release. Tactical and land camouflage paint scheme markings shall be in accordance with 5.2.3.

5.2.2.10.6.14 External exit emergency release. Each external exit emergency release or handle shall be identified by a "Rescue" arrow applied on the fuselage. The arrow shall be in accordance with Appendix A, figure A-13, colored orange-yellow, FED-STD-595, color number 13538. Other markings (i.e. "Step" or "Access Door") may be omitted to accommodate this marking.

5.2.2.10.6.15 Transport aircraft. The compartments of transport aircraft shall be marked with individual compartment horizontal dimensional references, the compartment centroids, the compartment letter designations, and the compartment maximum structural capacity in pounds. Cargo compartments

MIL-STD-2161A(AS)

shall also be marked in inches from the horizontal reference datum at 20 inch intervals. This requirement does not apply to transport aircraft with executive interior configurations.

5.2.2.10.6.15.1 Internal removable escape panels. Identification marking of escape hatches, doors, and exits shall be colored orange-yellow, FED-STD-595, color number 13538, on non-yellow surfaces. On yellow surfaces, the marking shall be colored black, FED-STD-595, color number 17038. Retroreflective material, conforming to L-S-300 may be used for this marking. The periphery of the escape panels shall be identified by an intermittent band, colored orange-yellow FED-STD-595, color number 13538. The segments of the band shall be a minimum of 1 inch width and a maximum of 2 inch length, divided equally between the door mount and the escape door. Where the door lining will cover the marking on the inside of the aircraft, the marking shall continue onto the lining.

5.2.2.10.6.15.2 Emergency exit marking. The words "Emergency Exit" colored orange-yellow, FED-STD-595, color number 13538, shall be painted or stenciled onto the escape hatch, door or exit, or any covering thereof, in the most readily visible location. Letters shall be a minimum of 2 inches high and shall not be less than 1 inch wide.

5.2.2.10.6.15.3 Handles, releases, catches, and knobs for inside panels. Handles, releases, catches, and knobs for inside hatches, exit doors, and their soundproofing (or lining) shall be painted orange-yellow, FED-STD-595, color number 13538. Suitable descriptive wording, readily visible, shall be painted or stenciled on the door or structure of the aircraft, whichever is nearer the emergency release, to identify and explain its operation. This wording shall be at least 1/2 inch high, using standard English terminology such as "Pull", "Push", "Turn" or "Slide". Exits which are adequate for air, ground, and ditching escape shall have the words "Emergency Exit" centered in the most visible location on the inside of the door or hatch. Exits which are not adequate for the above three methods of escape shall be marked "Emergency Exit," and for specific usage, "Ground Use Only," "Ground and Ditching Use Only," etc.

5.2.2.10.6.15.4 External removable escape panels. Markings identifying external removable escape hatches, doors, and exits on the outside of aircraft shall be orange-yellow, FED-STD-595, color number 13538; on yellow surfaces, black, FED-STD-595, color number 17038, shall be used. Retroreflective material conforming to L-S-300 may be used for these markings to facilitate identification in the dark. Mark all external releases for operation of emergency exit panels "Exit Release" on the outside of the aircraft to facilitate identification. The writing that describes the operation of the exit release will be standard english terminology such as "Pull", "Push", "Turn" or "Slide". Letters shall be at least 1 inch high. Tactical paint scheme aircraft shall be in accordance with 5.2.3.

MIL-STD-2161A(AS)

5.2.2.10.6.15.5 Markings for forced emergency entry or exit. Markings for aircraft emergency entry or exit shall be orange-yellow, FED-STD-595, color number 13538. Black, FED-STD-595, color number 17038, shall be used on yellow-orange backgrounds. Retroreflective material conforming to L-S-300 may be for these markings. Tactical and land camouflage paint scheme markings shall be in accordance with 5.2.3.

5.2.2.10.6.15.6 Secondary openings. Secondary openings, such as auxiliary exits, windows, and navigator's domes, are usually smaller than primary openings, making entrance or exit more difficult. If the structure immediately surrounding secondary openings is free from heavy structural members (such as bulkheads and the main longitudinal member), and from oxygen, fuel, and oil lines, and battery leads, it shall be marked with an orange-yellow, FED-STD-595, color number 13538, broken band. The band shall be located at the extreme boundary of the above described area, both inside and outside of the fuselage. Segments of the broken band shall be 1/2 inch wide, 1 inch long and approximately 12 inches apart. Where the band will be covered with soundproofing, the soundproof (or lining) shall be marked also. "Cut Here for Emergency Rescue" shall be printed or stenciled inside of, parallel with and adjacent to the broken band identifying the area on the outside of the aircraft where forced entry can be made for rescue purposes. "Cut Here for Emergency Exit" shall be painted on a similar location inside the aircraft. Letters shall be 1 inch high. If the area to receive the lettering is covered by soundproofing (or lining), the letters shall also be stenciled on the soundproofing (or lining). Tactical and land camouflage paint scheme markings shall be corner markings in accordance with 5.2.3.

5.2.3 Tactical and land camouflage paint scheme markings. All markings specified in 5.2.2 and 5.2.5 are applicable to aircraft which have either a land camouflage (LC) scheme or tactical paint scheme (TPS). Requirements for the colors of all the markings and the size of some of the markings differ when applied to aircraft possessing the tactical or land camouflage paint scheme. These differences in requirements are specified in the following paragraphs.

5.2.3.1 Color of markings on land camouflage scheme painted aircraft. All exterior markings of 5.2.2 and 5.2.5 applied to aircraft possessing the green, black and blue land camouflage scheme shall be applied utilizing the following guidelines:

- a. If the background color is blue, FED-STD-595, color number 35237, or green, color number 34095, the marking shall be black, color number 37038.
- b. If the background color is black, FED-STD-595, color number 37038, the marking shall be green, color number 34095.

MIL-STD-2161A(AS)

5.2.3.2 Color of markings for aircraft with tactical paint schemes. All exterior markings of 5.2.2 and 5.2.5 applied to aircraft possessing a tactical paint scheme shall be applied in a contrasting shade of gray, the color of which is dependent on the gray colors used for the specific tactical paint scheme and the location of the marking. See Appendices A, B and C for examples.

5.2.3.2.1 Tactical paint scheme - general marking policy. Tactical paint schemes are comprised of either two or three shades of gray. If the tactical paint scheme is comprised of only two colors, the contrasting color specified is the color used in the scheme which is not located in the area where the marking is applied. This requirement applies except when the two colors used in the scheme are FED-STD-595, color numbers 36320 and 36375. In this case, all markings will be applied in FED-STD-595, color number 35237. If the tactical paint scheme is comprised of three colors, the following guidelines apply:

- a. If the background color is the darkest gray, medium gray is used for the marking.
- b. If the background color is the medium gray, the darkest gray is used for the marking.
- c. If the background color is the lightest gray, the medium gray is used for the marking.

5.2.3.2.2 Color of MODEX numbers. MODEX numbers applied to aircraft with the tactical paint scheme shall be FED-STD-595, color number 36081 instead of the colors specified in 5.2.3.2.1.

5.2.3.3 Size of markings when used on aircraft with tactical or land camouflage paint schemes. The size of the markings when used on tactical or land camouflage paint scheme painted aircraft are the same sizes as specified in 5.2.2 and 5.2.5 except that the branch of service marking, call number and national insignias shall be a maximum of 12 inches high. Additionally, branch of service markings will not be applied to the wings.

5.2.3.4 Paint scheme deviations approval. Deviations to paint schemes for one aircraft may be approved by the Type Commander. Deviations for more than one aircraft require prior approval by the Naval Air Systems Command (AIR 5164) and possibly CNO.

5.2.4 Marking materials. Marking materials must conform to the gloss and IR requirements of the coating used to apply tactical and land camouflage schemes. Decals may be used for small markings (maximum of 4 inches) if all other requirements are met.

MIL-STD-2161A(AS)

5.2.5 Exterior maintenance precautionary and warning markings.

5.2.5.1 Aircraft and missile service point identification symbols and markings. Service point identification and precautionary warning markings shall be applied on all aircraft and missiles, as required (see Appendix B, figures B-7, B-8, and B-9). All NATO markings, as referenced to in 5.2, are required. NATO markings are detailed in Appendix B, figures B-3, B-4, B-5, and B-6. The location of these markings will vary with airframe configuration. Each marking shall be displayed to provide the following:

- a. Rapid identification of each required servicing point.
- b. Identification of the type of ground servicing required.
- c. Hazard warning of safety precautions which will prevent injury to personnel or damage to aircraft equipment.
- d. Rapid entry or exit from vehicle under emergency conditions.

5.2.5.1.1 Application of service point identification symbols and marking. When applying these symbols and markings, the instruction provided by Appendix B shall be adhered to. The symbols shall not exceed 4 inches in width or height. Application may be accomplished using paint, or decals conforming to MIL-P-38477 or MIL-M-43719. When paint is used, stencils incorporating capital letters and arabic numerals not exceeding 1 1/4 inches in height shall be used; freehand application is prohibited. When applied to a gray or white background, the marking shall be black, FED-STD-595, color number 17038. On other backgrounds, the marking shall be white, FED-STD-595, color number 17925. A decal similar to Appendix B, figure B-6, shall be located inside the nose wheel well, or nose wheel door, defining the location of service points.

5.2.5.1.2 Location. The location of each service point marking shall be based upon the existing available space. They may be situated on the equipment concerned, directly below, adjacent to, or on applicable access panels. In the event that the service point or marking is concealed, arrows may be used to point out the location of the service point. The arrows shall bear a brief identification of the purpose for which it is applied.

5.2.5.1.3 Hydraulic system and landing gear/struts. Servicing instructions for hydraulic systems, landing gear, and shock struts, shall be provided on metal instruction plates, or stenciled in a permanent and legible manner, adjacent to charging points and test connections.

5.2.5.2 Fuel nozzle jumper plug receptacles. Fuel nozzle plug receptacles shall be marked in accordance with MIL-C-83413/9.

5.2.5.3 Aircraft grounding points. All grounding points on all U.S. Navy aircraft shall be marked in accordance with Appendix B, figures B-3, B-8, and B-9.

MIL-STD-2161A(AS)

5.2.5.4 Storage batteries. On all battery access doors, the word "BATTERY" shall be painted in insignia red, FED-STD-595, color number 11136. The lettering shall be 1 inch high on aircraft with a tactical paint scheme and the color shall be in accordance with 5.2.3. On the left side of the fuselage, as viewed from the rear of the aircraft, there shall be a notation "BATTERY LOCATION _____". The exact location shall replace the line "_____". The fore and aft positioning of the markings shall be approximately in line with the trailing edge of the wings, and the vertical positioning 2 to 3 feet above the bottom of the fuselage. For instances where there are windows, enclosures, etc., in this position, the storage battery for marking shall be placed as near to the specified position as possible. Where there are battery locations interior to the aircraft, the word "Battery" or "Batteries", as applicable, shall be permanently and conspicuously affixed to the battery casing or compartment. The marking shall be in 1 inch high letters.

5.2.5.5 Instrument static opening markings. Instrument static openings (except as noted below) shall have no finish applied within a 1 inch diameter circle around the opening. A red, FED-STD-595, color number 31136, 1/2 inch wide circular band shall be applied around this area. The following legend shall also be applied adjacent to the marking: "Instrument Static Opening - Do Not Cover". Aircraft painted with the tactical and land camouflage schemes shall be painted in accordance with 5.2.3.

5.2.5.6 Wing fold warning flag. On aircraft having wing fold warning flags, the flags shall be painted red, FED-STD-595, color number 31136. Aircraft painted with the tactical and land camouflage schemes shall be painted in accordance with 5.2.3.

5.2.5.7 Markings for electrical connections. The following caution note shall be placed at points where it is necessary to break electrical connections when folding back or removing wings, or removing tail surfaces, etc: "CAUTION, Disconnect Electrical Wiring Before Removing Part". The color of the letters shall be black, FED-STD-595, color number 17038.

5.2.5.8 Markings for engine removal. All points of disconnect will be painted either black, FED-STD-595, color number 17038, or with contrasting gray for tactical paint schemes (see 5.2.3).

5.2.5.9 Markings for tank and filler areas.

5.2.5.9.1 Tank. Aircraft tanks shall have notations indicating tank capacity, type of liquid, and level restrictions. Tank markings shall be the same color as that used on attaching lines. Additional data, such as coolant mixture, water-alcohol mixture, and grade of liquid shall be stenciled near the filler caps in letters 1/2 inch high in the same color as that used to indicate tank capacity. Stenciling on the fuel tanks shall read: "Use _____ Octane Fuel or Better," or "Use Grade _____ or Better," as applicable.

MIL-STD-2161A(AS)

5.2.5.9.2 Filler caps. Filler caps for fuel and oil tanks and other external parts and attachments for which identification is necessary and desirable shall be painted the color assigned to the applicable fitting and shall be indicated by appropriate markings. Where flush-type pressure fueling caps, conforming to MS29525 are installed, three radial black lines, FED-STD-595, color number 37038, 3/8 inch wide by 1 inch long, shall be located as to form extensions to the lines on the cap when the cap is in the locked position. Tactical paint scheme aircraft shall be painted in accordance with 5.2.3. The type and grade of fuel to be employed in the aircraft shall be indicated adjacent to the filler caps in accordance with Appendix B, figure B-3, and B-5.

5.2.5.10 Lift points, hand grips, caution legends, etc. These shall be indicated by appropriate wording painted in black, FED-STD-595, color number 17038 adjacent to the applicable point. Tactical or land camouflage paint scheme aircraft shall be painted in accordance with 5.2.3. Appendix B, figures B-4 and B-7 provide examples of this marking.

5.2.5.11 Baggage compartment, life raft stowage, etc. These shall be indicated by means of appropriate signs painted in black, FED-STD-595, color number 17038, adjacent to the area. Color of the marking for aircraft painted with a tactical or land camouflage paint scheme shall be in accordance with 5.2.3.

5.2.5.12 Wing access panel latches and safety straps. On aircraft which have wing access panel latches and safety straps, the inside lever and wing area under the latch safety strap shall be painted insignia red, FED-STD-595, color number 11136, in such a manner that no red color will show when the latches and straps are properly secured.

5.2.5.13 Actuating mechanism warning signs. A black, FED-STD-595, color number 17038 warning sign shall be located adjacent to any actuating mechanism which can cause damage to the weapons systems from improper or out-of-sequence operation. The color of the marking for aircraft painted with a tactical or land camouflage paint scheme shall be in accordance with 5.2.3.

5.2.5.14 Recessed lubrication fittings. Flush type (female receptacle) grease fittings, recessed set screws, or depressed adjustments, such as may be found on rotor control and drive shafts, but which require periodic servicing or inspection, shall be identified with a circumscribed band of orange, FED-STD-595, color number 12197, not exceeding 1 inch in width. Color for aircraft with tactical or land camouflage paint schemes shall be painted in accordance with 5.2.3.

5.2.6 Optional markings.

5.2.6.1 Squadron designation. The squadron designation identifies with letters and numerals the squadron to which the aircraft is assigned. It shall be placed on both sides of the fuselage, just forward of the empennage, and centered under the branch of service marking. If this is not practical due to

MIL-STD-2161A(AS)

space limitations, the squadron designation may be applied in an aft location designated by the cognizant command. The squadron designation on low-wing transports shall be applied along the centerline on both sides of the fuselage, just forward of the empennage. On high-wing transports, if the branch of service marking is placed on the fuselage either, under the wing, or aft of the trailing edge of the wing, the squadron designation shall be centered symmetrically under the marking. If this is not practical, it shall be centered under the marking, or placed aft, along the fuselage, below the centerline.

5.2.6.2 Reserve aircraft markings - station names. The name of the home station may be placed on both sides of the fuselage just forward of the empennage and centered under the branch of service marking. This shall be in addition to the station letter on both sides of the vertical fin and rudder. On transport aircraft (VR), where the branch of service marking is placed along the fuselage above the windows, the station name shall be placed along the centerline on both sides of the fuselage, just forward of the empennage. This shall be in addition to the station letter on both sides of the vertical fin and rudder. The letters used for reserve station identification shall be one half the size of the branch of service marking.

5.2.6.3 Battle "E". Squadrons selected for the battle "E" are entitled to display a white, FED-STD-595, color number 17925, letter "E" on all assigned aircraft for the length of one competitive cycle following the date of award. The "E" shall be painted on the starboard side of the aircraft in the vicinity of the cockpit, in a rectangular block type letter not to exceed 8 inches in height and in proportional width. Where the "E" is awarded to the same squadron for consecutive competitive cycles, a service hash mark shall be painted under the letter. This hash mark shall be the width of one stroke and of the same color as the "E". The hash mark shall be 30 degrees to the horizontal from the lower left hand of the "E". When applied to aircraft with a tactical or land camouflage paint scheme the color of the "E" and hash mark shall be gray, FED-STD-595, color number 36081, and for land camouflage schemes black, FED-STD-595, color number 37038.

5.2.6.4 Safety "S". Squadrons winning this award are authorized to display an "S" for safety marking on their aircraft. Authorization will extend through the calendar year subsequent to the year for which the award was won. An appropriate hash mark is approved only for squadrons who are repeat winners in consecutive years. The "S" for safety shall be white, FED-STD-595, color number 17925, or black, FED-STD-595, color number 17038, and is to be of an appropriate size not more than 8 inches in height. It is to be displayed under the squadron insignia (when used) and shall not interfere with required markings. For tactical paint schemes the color of the "S" shall be gray, FED-STD-595, color number 36081, and for land camouflage schemes black, FED-STD-595, color number 37038. Lettering shall be in accordance with 5.2.1. Consecutive year marking shall be accomplished in the same way as the battle "E" hash mark (see 5.2.6.3).

MIL-STD-2161A(AS)

5.2.6.5 Hospital aircraft red cross. When aircraft are assigned air evacuation or hospital duty, this marking is mandatory. It shall be centered on both sides of the vertical tail surface, above the horizontal stabilizer, in the space normally allotted to the unit identifier. It shall also be placed on the upper surface of the right wing with the center of the marking at a distance from the wing tip equal to one third of the distance from the fuselage to the wing tip, and in a similar location to the national insignia of the opposite wing, and on the under surface of the right wing, located symmetrically between the national insignia and fuselage. Hospital aircraft shall be identified by a Geneva Red Cross consisting of a symmetrical glossy insignia red, FED-STD-595, color number 11136, cross on a glossy white, FED-STD-595, color number 17925, disc (see Appendix A, figure A-19). The insignia shall consist of five red squares arranged in the form of a symmetrical cross centered inside the white circumscribed circle. The length of the red cross shall be $15/19$ of the diameter of the circumscribed circle. The diameter of the circumscribed circle shall be $2/3$ of the mean chord of the vertical tail surface.

5.2.6.6 Aircraft pilot and crew chief names. The names of the regular aircraft pilot and/or the aircraft crew chief may be applied to the nose wheel door of camouflaged and non-camouflaged aircraft at the option of the Type Commander. Block lettering 2 inches high in black, FED-STD-595, color number 17038, on a white background, FED-STD-595, color number 17925, may be applied inside of the nose wheel well door.

5.2.7 Special purpose marking for U.S. Navy aircraft. Unless otherwise specified, the dimensions, colors, and materials markings shall also apply to special purpose markings. Due to variance in equipment configuration and restrictions in the uses of some markings, special purpose markings may or may not be applicable to all aircraft. However, when applicable and authorized for use, special purpose markings will be applied in the dimensions, colors and locations as specified herein.

5.2.7.1 Identification of naval attache (ALUSNA) aircraft. The marking for naval attache also applies to naval mission. Either marking may be applied, as applicable.

5.2.7.1.1 Fuselage marking. The United States Navy marking will be located on the fuselage in the same place as for the transport aircraft (see 5.2.2.4). The lettering shall be the largest possible size which can be accommodated on the aircraft, selected from 5.2.

5.2.7.1.2 Naval attache fuselage marking. ALUSNA markings may be deleted on the basis of local, diplomatic, or other considerations. Fuselage markings for ALUSNA aircraft shall consist of the following words: "United States Naval Attache to (name of country)." For the benefit of foreign personnel, the same wording in the language of the country to which the attache is accredited, shall be placed approximately 2 inches below the American wording. This foreign language inscription shall be applied under

MIL-STD-2161A(AS)

the supervision of personnel who have a thorough knowledge of the foreign language involved. In the event that there is more than one form of script of the foreign language, the selection shall be determined by the foreign country. All letters shall be painted or stenciled in white on a dark background or in black on a light background.

5.2.7.1.2.1 Location. The attache fuselage marking shall be forward on the aircraft, approximately under the pilot's cockpit, on both sides of the fuselage. For C-1A and larger aircraft, the English language inscription shall be located above the centerline of the fuselage and the foreign language inscription shall be located below the centerline of the fuselage. For smaller aircraft, the English and foreign language inscriptions shall be located just below the pilot's window.

5.2.7.1.2.2 Size. For C-1A and larger aircraft, the lettering of the English and foreign language inscription shall be 4 inches high. For smaller aircraft, the size of the lettering shall be reduced proportionately.

5.2.7.1.3 Naval attache wing marking. The wing marking for naval attache aircraft shall consist of an American flag, conforming to Appendix A, figure A-18.

5.2.7.1.3.1 Location. The American flag shall be located on the underside of the left wing, approximately under the national insignia on the top side of the left wing. The branch of service marking shall not be used on the wing for ALUSNA aircraft. The flag shall be centered and applied so that an observer on the ground, with airplane approaching, will view the flag with the blue field forward and to his left, and with the stripes extending outboard. If more positive identification is required because of local conditions or other considerations, an additional American flag may be applied to the top side of the right wing on an interim basis. This flag shall be removed when local considerations permit. The flag size shall be the same as that applied to the underside of the left wing and shall be located approximately over the national insignia on the underside of the right wing.

5.2.7.1.3.2 Size. The flag shall be in the proportions of 1.9 feet in length to 1.0 foot in width, in accordance with standard American flag requirements. In no case, however, shall the width exceed 75 percent of the distance between the leading edge of the wing and the aileron cutout at the point of application. In all cases, the largest size flag which can be accommodated on the wing shall be used.

5.2.7.1.4 Naval attache vertical stabilizer marking. The vertical tail surface marking for naval attache aircraft shall consist of an American flag.

MIL-STD-2161A(AS)

Note: At the discretion of cognizant commands, American flags, similar to the configuration specified for ALUSNA aircraft, may be applied (except on tactical or land camouflage scheme painted aircraft) on both sides, or on the two outboard sides of the vertical tail surface of transport aircraft to facilitate recognition by foreign countries over-flown, or for other important considerations. Such markings shall be deleted after their purpose has been served.

5.2.7.1.4.1 Location. The American flag shall be positioned horizontally and in such a manner that the union shall be uppermost on both sides of the vertical tail surfaces. For aircraft having multiple vertical tail surfaces, the flag shall appear only on the two outboard sides. On both sides of the aircraft the flag shall be applied with the blue field forward and the stripes extending aft. The bars of the flag shall appear to be trailing at all times. The flag shall be centered on the surface and placed above all other marking.

5.2.7.2 Standard American flag sizes. Appendix A, figure A-18, the following standard sizes (length by width) are specified for American flag markings used on U.S. Navy aircraft:

- a. 19 x 36 inches
- b. 21 x 40 inches
- c. 25 x 48 inches
- d. 31.4 x 60 inches

The flag or national insignia/emblem of any country, other than the United States of America, will not be displayed on any U.S. Navy aircraft for any reason.

5.2.7.3 Presidential helicopter. For layout and description of markings required on presidential helicopters, refer to Appendix D, figure D-6.

5.2.8 Marking of foreign aircraft. Aircraft procured by foreign countries through the Department of Defense shall be marked in accordance with this standard, except that the U.S. national insignia will be replaced with the foreign country's national insignia. National insignias for various countries are provided in Appendix F.

5.2.9 Access panel identification. Interior and exterior aircraft panels, plates, and access doors which require opening or removal at the time of inspection or overhaul shall be identified by the access numbering system in accordance with MS90327.

MIL-STD-2161A(AS)

5.2.10 Walkways and honeycomb panels. Walkways and honeycomb panels shall be marked as follows:

5.2.10.1 Walkways and steps. In cases where they do not contrast in color with adjacent areas, walkway areas shall be bounded by a camouflage black, FED-STD-595, color number 37038 line for a light background or a camouflage white, FED-STD-595, color number 37925 line for a dark background, 1/2 inch wide, and marked with the word "Walkway" at sufficiently frequent intervals to indicate the walkway area. Steps shall be suitably indicated at all points on the aircraft. On the exterior of aircraft with a tactical or land camouflage paint scheme, the walkway areas shall conform to 5.2.3.

5.2.11 Honeycomb panels on airplanes. Honeycomb panels (thin skin) for wing upper surfaces shall be distinctly marked by a 1 1/2 inch wide stripe of hash marks; each hash mark shall be 2 inches long, measured along the stripe with 2 inches between marks. The marks shall slope 45 degrees. The markings shall be painted on, with a material which is compatible with the finish on the aircraft, in the area of application. On the exterior of aircraft with the tactical or land camouflage paint scheme, the markings shall conform to 5.2.3.

5.2.12 Powerplant.

5.2.12.1 Powerplant removal. When making a powerplant assembly change, all systems, lines, conduits, control rods, cables, bell ranks and castings flanges shall be marked at the point of disassembly. The marking shall be a painted band not exceeding 1 inch in width, of a material which is compatible with the finish on the aircraft, in the area of application.

5.2.12.2 Powerplant controls. All engine control units shall be marked in the vicinity of the lever and in such position that the lever marking association is clear as shown in table III.

MIL-STD-2161A(AS)

TABLE III. Powerplant control markings. 1/

Control 1/	Extreme positions	
Throttle	Open	Closed
Mixture	(see 5.2.12.2.1)	
Shutter	Open	Closed
Carburetor heat	Hot	Cold
Propeller	Decrease rpm	Increase rpm
Supercharger (if turbo)	On	Off
Supercharger (if 2-speed geared)	High	Low

1/ In marking the control levers, the abbreviations T, M, S, P, and B may be used for the throttle, mixture toggle switch, propeller, and supercharger levers, respectively. Standard control knobs (other than landing gear and fire extinguisher) shall be gray, color number 16473, of FED-STD-595.

5.2.12.2.1 Mixture control lever. A plate on which the carburetor control positions are marked shall be installed adjacent to the mixture control lever. The markings shall be white letters on a black background, except IDLE CUT-OFF, which shall be white lines on a red background. The lines shall indicate the position of the middle of the control lever when the lever on the carburetor is in the appropriate notch.

5.2.12.3 Fuel system diagram. A fuel system diagram shall be provided in the cockpit of each aircraft. The fuel system diagram shall be a simple schematic layout of the fuel system with the fuel selector valve or valves displayed in a prominent manner. Lines such as normal tank vent lines, primer lines, and pressure-gage lines need not be shown on the fuel system diagram, which is intended to aid the pilot in obtaining a clear picture of that part of the fuel system with which he is concerned in flight. All fuel system diagrams shall be of sufficient size and clearance for the purpose intended.

5.2.13 Fluid line identification. All fluid lines shall be marked in accordance with MIL-STD-1247.

5.2.13.1 Color code (identification chart). Identification chart color codes in accordance with MIL-STD-1247 shall be installed in all aircraft, as follows:

- a. One identification chart color code shall be installed in each engine nacelle on all aircraft for the use of the ground crews. For multiengine aircraft, additional identification chart color codes shall be installed, one per engine.

MIL-STD-2161A(AS)

- b. Identification chart color codes are not needed in single-place aircraft for the use of the pilot. One such code shall be installed at each crew station in two-place aircraft, and one shall be installed near each crew station in multiplace aircraft, with a maximum of four per aircraft.

5.2.14 Parts markings. Markings for parts, structural assemblies, fluid lines, wiring controls, servicing points, etc., shall be in accordance with MIL-STD-1247, MS90327, and as specified herein.

5.2.15 Reworked or special parts. Parts, equipment, and assemblies, including special bolts and reworked items as altered or selected for special fit, performance, or tolerance, shall be marked in accordance with MIL-STD-130. Such markings shall be accomplished in a manner that will not adversely affect the life and utility of the item.

5.2.16 Identification of tubes, hoses, and pipelines for aircraft. The means for identification of the function, content and, if applicable, the hazard and direction of flow of pipe, hose and tube lines used in U.S. Navy aircraft shall be in accordance with MIL-STD-1247. The proper use of colors, words, symbols, tags and painted bands to identify functions, contents and hazards is specifically prescribed. Lines refer to any pipe, hose or tube used to convey liquids or gases as well as rigid conduits used to house electrical wires or cables. Fittings, valves, conduit outlets and accessories such as pipe covering and hose clamps are considered parts of a line.

5.2.17 North Atlantic Treaty Organization (NATO) code numbers. The application of NATO code numbers is described in Appendix B. The codes are applied immediately adjacent to the service symbol. NATO code numbers may be omitted on training-type aircraft and other aircraft not serviced overseas. Application of the code numbers is supplemented by applicable service points described in Appendix B.

5.2.18 Data cards. Data cards and check lists shall be mounted in the cockpit or in an accessible position. These cards shall be given a coat of clear shellac, or other transparent protective material. A drawing of the data cards, properly filled in, shall be furnished with drawings, in accordance with MIL-STD-100.

5.2.19 Marking of loose and jettisonable equipment. The following loose equipment shall be marked in a contrasting color, using a stencil or other suitable marking, with the call numbers: life rafts; tool kits peculiar to the airplanes; aircraft covers, that is engine covers, dust covers, etc., equipment specifically calibrated for the airplane, such as drift meters, tuning units, etc., and jettisonable equipment such as canopies, wing tanks, and ejection seats. Ejection seats shall include abbreviation of the operator; such as PLT, CO-PLT, NAV.

MIL-STD-2161A(AS)

5.2.20 Identification of escape system ballistic hose and tubing.

5.2.20.1 Propellant gas system. The hose, tubing or mild detonating cord assemblies used to transmit propellant gas pressure between the various cartridge-actuated devices of an escape system shall be taped in accordance with MIL-STD-1247 (compressed gas) with the following information printed in black letters on the tape:

ESCAPE SYSTEM
NORMAL -- EMPTY
EMERGENCY -- HOT GASES

5.2.20.2 Escape subsystem. The particular subsystem of the escape system in which the hose, tubing, or mild detonating cord assemblies are installed shall be identified directly adjacent to the identification tape required by 5.2.20.1 by affixing white tape with black lettering that identifies the particular subsystem. An example is:

CANOPY JETTISONING SYSTEM	CONTROL COLUMN STOWAGE SYSTEM
------------------------------	----------------------------------

5.2.20.3 Hose, tubing, and detonating cord assemblies. The extremities of the hose, tubing, or mild detonating cord assemblies shall be identified by applying white tape with black lettering that indicates the component, device, AN fitting, etc., to which the particular extremity is to be attached. Examples are:

CONNECT TO UNION AN815-4	CONNECT TO M3 INITIATOR	CONNECT TO CHECK VALVE AN6207-4	CONNECT TO M5 CATAPULT
--------------------------------	-------------------------------	---------------------------------------	------------------------------

5.2.20.4 Ground rescuer marking of hose and tubing assemblies. For ground rescue purposes all ballistic hose or tubing assemblies leading to the catapult shall be painted. The area painted shall be approximately 8 inches long and shall be between the initiator for the catapult and the catapult. The area selected shall be easily visible, readily accessible, and as close as possible to the catapult.

5.2.21 Emergency light switch. The emergency light switch, when installed, shall be indicated by a self-luminous marker with the phosphor and exciter sealed in a plastic and metal container. Radioactive paints shall not be used.

5.2.22 Dinghy (raft) release and flotation controls. Operating handles and levers shall be striped orange-yellow and black alternating lines; the title and operating instructions shall be orange-yellow. The letters of titles shall be at least 1 inch high and the letters of operating instructions not less than 1/2 inch high. If the control is in the form of a switch, then the size of the letters may be reduced to a size appropriate to the location.

MIL-STD-2161A(AS)

5.3 Workmanship. Insignia and markings shall be uniform in quality and shall be free from irregularities, defects or foreign material which could adversely affect performance, reliability or durability. Insignia or markings not applied in accordance with acceptable level of workmanship or not in accordance with the requirements of this standard shall be removed and reapplied.

MIL-STD-2161A(AS)

6. NOTES

(This section contains information of a general or explanatory nature that may be helpful, but is not mandatory.)

6.1 Intended use. The purpose of this standard is to specify paint schemes and insignia markings for all U.S. Navy and Marine Corps aircraft, including identification plates for the aircraft and major assemblies, and warning and instruction markings.

6.2 Issue of DODISS. When this standard is used in acquisition, the applicable issue of the DODISS must be cited in the solicitation (see 2.1.1).

6.3 Data requirements. The following Data Item Descriptions (DID's) must be listed, as applicable, on the Contract Data Requirements List (DD Form 1423) when this specification is applied on a contract, in order to obtain the data, except where DOD FAR Supplement 27.475-1 exempts the requirement for a DD Form 1423.

<u>Reference Paragraph</u>	<u>DID Number</u>	<u>DID Title</u>	<u>Suggested Tailoring</u>
4.3, 5.2.2.1 & 5.2.18	DI-DRPR-80651	Engineering drawing	Use contractor format

The above DID's were those cleared as of the date of this specification. The current issue of DOD 5010.12-L, Acquisition Management Systems and Data Requirements Control List (AMSDL), must be researched to ensure that only current, cleared DID's are cited on the DD Form 1423.

6.4 Toxicity. Some free isocyanate is released during the mixing and application of multi-component polyurethane coatings. Released free isocyanates can produce a significant irritation to the skin, eyes, and respiratory tract. Personnel exposed to free isocyanates may develop and allergic pulmonary sensitization, particularly if there is an inhalation of the vapor and mist produced during spray application. This sensitization may cause an asthmatic reaction with wheezing, dyspnea, and cough. Once sensitized, further exposure cannot be tolerated. For this reason, there is a restriction of the issuance and use of this material. Personnel exposed to free isocyanates on a regular basis should receive a periodic medical exam that includes a chest roentgenograph (X-ray), pulmonary function tests, and an evaluation of any respiratory disease or history of allergy. Periodic testing of pulmonary functions may aid in detecting the onset of pulmonary sensitization.

6.4.1 Personnel protective methods. Eye protection and appropriate clothing to prevent repeated or prolonged skin contact should be worn while applying material that contains free isocyanates. Additional information pertaining to protective equipment and other necessary precautions should be available from the coating application facility's occupational safety and health office.

MIL-STD-2161A(AS)

6.5 Subject term (key word) listing.

Aircraft color patterns
Emergency warnings
Hazard warnings
Identification
Insignias

6.6 International standardization. Certain provisions of this standard are the subject of international standardization agreement (ASCC 25/1, 25/3A and STANAG 1135, 3104, 3109). When amendment, revision, or cancellation of this specification is proposed which will modify the international agreement concerned, the preparing activity will take appropriate action through international standardization channels, including departmental standardization offices, to change the agreement or make other appropriate accommodations.

6.7 Changes from previous issue. Marginal notations are not used in this revision to identify changes with respect to the previous issue due to the extensiveness of the changes.

Preparing activity:
Navy - AS
(Project MFFP-N518)

MIL-STD-2161A(AS)

APPENDIX A

STANDARD MARKING, EMERGENCY AND HAZARD WARNING MARKINGS FOR AIRCRAFT

10. SCOPE

10.1 Scope. This appendix specifies the design of standard markings (including the national insignia), emergency, and hazard warning markings for fixed wing and rotary wing aircraft.

10.2 Use. This appendix is a mandatory part of this standard. The information contained herein is intended for compliance.

20. APPLICABLE DOCUMENTS

20.1 Government documents.

20.1.1 Specifications and standards. The following specifications and standards form a part of this document to the extent specified herein. Unless otherwise specified, the issues of these documents are those listed in the issue of the Department of Defense Index of Specifications and Standards (DODISS) and supplement thereto, cited in the solicitation.

SPECIFICATIONS

FEDERAL

DDD-F-416	-	Flag, National, United States of America, and Flag, Union Jack
-----------	---	--

MILITARY

MIL-F-18264	-	Finishes, Organic, Weapon System, Aircraft, Application and Control of
-------------	---	--

MIL-P-38477	-	Plastic Material, Pressure Sensitive Adhesive, for Aircraft Identification and Marking
-------------	---	--

MIL-M-43719	-	Marking Materials and Markers, Adhesive, Elastomeric, Pigmented, General Specification for
-------------	---	--

STANDARDS

FEDERAL

FED-STD-595	-	Colors Used in Government Procurement
-------------	---	---------------------------------------

MIL-STD-2161A(AS)

(Unless otherwise indicated, copies of federal and military specifications, standards, and handbooks are available from the Standardization Documents Order Desk, Building 4D, 700 Robbins Avenue, Philadelphia, PA 19111-5094.)

20.2 Order of precedence. In the event of a conflict between the text of this document and the references cited herein (except for related associated detail specifications, specification sheets or MS standards), the text of this document shall take precedence. Nothing in this document, however, supersedes applicable laws and regulations unless a specific exemption has been obtained.

30. DEFINITIONS

30.1 Definitions. For purposes of the appendix, the definitions of this standard shall apply.

40. GENERAL REQUIREMENTS

40.1 National insignia.

40.1.1 National insignia design. The design of the national insignia shall conform to the requirements of this specification. As illustrated in figure A-1, it shall consist of an insignia-white, five-pointed star inside an insignia-blue circumscribed circle. A white rectangle, one radius of the blue circle in length and 1/2 radius of the blue circle in width, shall be located on each side of the star. The top edges of the rectangle shall be placed to form a straight line with the top edges of the horizontal two star points beneath the top star point. An insignia-red horizontal stripe, 1/6 the radius of the star, shall be centered in the white rectangles at each end of the insignia. A blue border, having a width of 1/8 the radius of the blue circle, shall outline the entire design except that when the insignia is to be applied on a sea blue, dark blue, or black background, the blue circle and border may be omitted. The inside edge of each interior rectangle shall be concave, and shall have the same arc as the inside blue circle. The inside edge of each outer rectangle shall not be depicted.

40.1.1.1 Size. The blue circle of the insignia for wing application, exclusive of border, shall have a maximum diameter of 40 inches and a minimum diameter of 10 inches. Sizes may vary by 5 inch increments in diameter. The blue circle diameter selected shall be the size which is closest to, but does not exceed, 50 percent of the distance between the leading edge of the wing and the aileron cutout at the point of application. For fuselage application, the blue circle shall have a maximum diameter of 40 inches and a minimum diameter of 10 inches. The diameter selected for fuselage application shall be closest to but not exceeding that which is 50 percent of the height of the projection of the fuselage or hull side. The most practical diameter shall be selected for helicopters and convertiplanes.

MIL-STD-2161A(AS)

40.1.1.2 Color. The standard colors of the national insignia are insignia red, FED-STD-595, color number 11136, insignia white, FED-STD-595, color number 17925, and insignia blue, FED-STD-595, color number 15044. Corresponding semigloss or lusterless finishes of the above listed gloss colors may be used to match adjacent surfaces only when specified by the procuring activity.

40.1.1.3 Application. Application of the national insignia by painting shall be in accordance with MIL-F-18264. When applying the national insignia by painting, a stencil shall be used to produce a sharp outline. The insignia shall be applied with coatings compatible with the finish applied to adjacent surfaces. Decals may be used in lieu of paint for application of the national insignia (see 40.1.5). The national insignia shall be so applied on horizontal surfaces that, in the normal flight attitude of the aircraft, the top star point of the insignia points forward, and a line through that point and the star's center is parallel to the line of flight, except for the swept wing or variable sweep wing configurations. On these aircraft, the national insignia shall be placed so that it will not extend onto flaps, slats, or control surfaces (see figure A-2). The constant 50 percent chord line of the wing which passes through the center of the star. For fuselage application, the insignia shall be placed so that the top star point points upward, and a line through that point and the star's center is perpendicular to the line of flight.

40.1.2 Wing insignia. One fixed wing aircraft, the national insignia shall be applied to the upper surface of the left wing, on the lower surface of the right wing, and on the fuselage, as shown in the figures of Appendix C. The insignia shall be placed at a distance from the wingtip equal to 1/3 of the distance from the fuselage to the wingtip, measured from the center of the insignia. It may be moved inboard where impractical (i.e. where wingtip floats of a seaplane interfere). The insignia shall not be applied to the wings of research aircraft when interference with aerodynamics will result. The size selected shall be that which is closest to, but does not exceed, 75 percent of the distance between the leading edge of the wing and the aileron cutout at the point of application. The wing insignia or other markings shall be omitted from the underside of wings or other surfaces on which thermal-resistant finishes are applied.

40.1.3 Fuselage or hull insignia. On fixed wing aircraft, the national insignia shall be applied to each side of the fuselage or hull. These locations are portrayed in the figures in Appendix C. The fuselage or hull insignia may extend over doors and emergency exits, but shall not extend over windows or openings used during combat. For aircraft with a tactical or land camouflage paint scheme the insignia shall be 12 inches in diameter, inclusive, or a contrasting color, and placed as directed by the applicable Naval Aviation Depot directive.

MIL-STD-2161A(AS)

40.1.4 Rotary wing aircraft insignia. Four national star insignias shall be applied to rotary wing aircraft, so as to be visible from either side and from above and below. If the configuration permits, an additional insignia may be applied to the nose of rotary wing aircraft for frontal identification. Symmetry of size and location shall be maintained on all like-model series aircraft.

40.1.5 Decalcomanias. Decals may be used for all small markings (less than 4 inches in size). For interior application, where they will not be affected by weather conditions, and for exterior application on low-performance aircraft, decals shall be applied in accordance with MIL-M-43719. For exterior application on high-performance aircraft and where subjected to extremes of temperature, speed, and altitude, MIL-P-38477 shall apply. MIL-P-38477 decals may be furnished with perforation holes upon request. These decals may be applied only over the complete paint system. Decal application shall not be deleterious to the aircraft surface. Decals shall not be applied over brazier head rivets.

40.1.6 Decalcomania letter heights. Letter heights shall be as follows:

Small: 1, 2, 3, 4 1/2, and 6 inches high
Medium: 9, 12, 15, 18, and 21 inches high
Large: 24, 30, 42, and 48 inches high

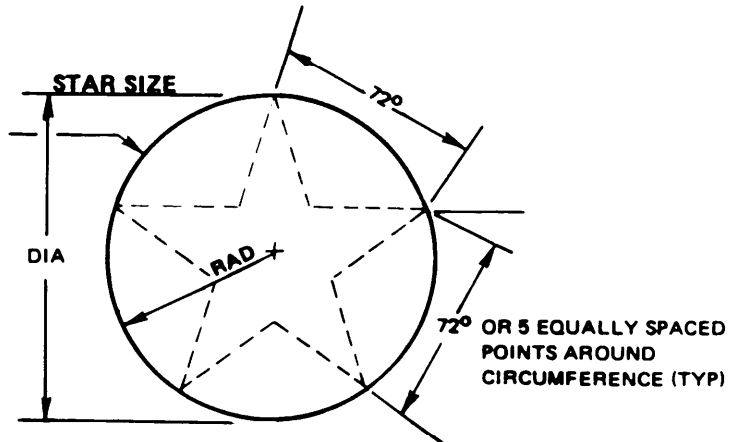
Decals larger than 48 inches in height may increase by 12 inch increments. Dimensions for letters shall maintain a 1/3 ratio for height, width, and stroke.

40.1.7 Tactical and land camouflage paint scheme national insignia. See 5.2.3 and figure A-1.

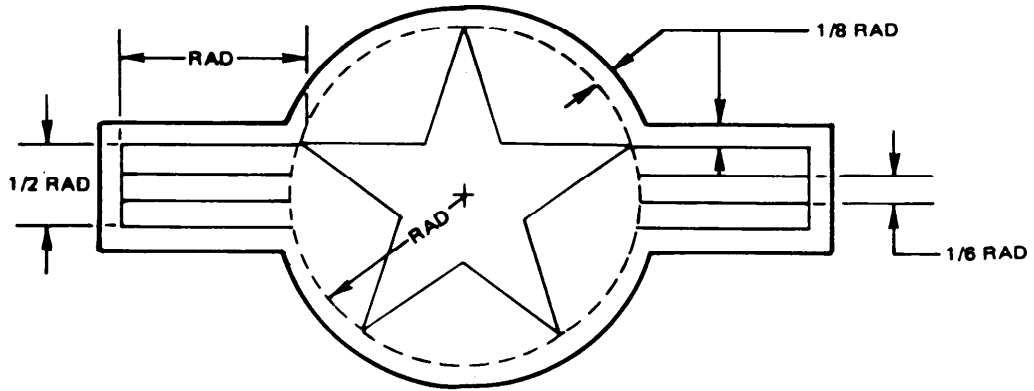
40.2 Aircraft markings. The following figures illustrate standard markings (including the national insignia), emergency, and hazard warning markings for fixed wing and rotary wing aircraft.

MIL-STD-2161A(AS)

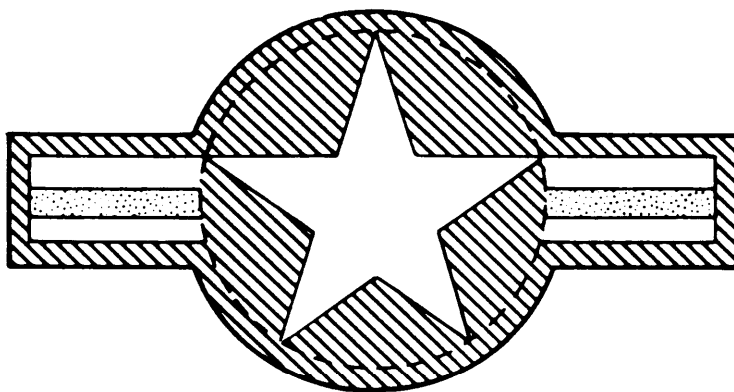
WHEN REFERENCE IS MADE TO SIZE OF INSIGNIA, THE REFERENCE IS TO THE SIZE OF THE BASIC CIRCLE ON WHICH THE WHITE STAR IS CONSTRUCTED AND NOT TO THE OUTER EDGE OF THE BLUE OUTLINE




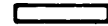

TEMPLATE OR STENCIL LAYOUT



CONSTRUCTION DETAILS





CONVENTIONAL

-  INSIGNIA RED, COLOR NO. 11136
-  INSIGNIA WHITE, COLOR NO. 17925
-  INSIGNIA BLUE, COLOR NO. 15044

TACTICAL PAINT SCHEME

-  BACKGROUND COLOR
-  CONTRASTING GRAY

LAND CAMOUFLAGE SCHEME

-  BACKGROUND COLOR
-  CONTRASTING CAMOUFLAGE COLOR

COLOR DIAGRAM

FIGURE A-1. National star insignia.

MIL-STD-2161A(AS)

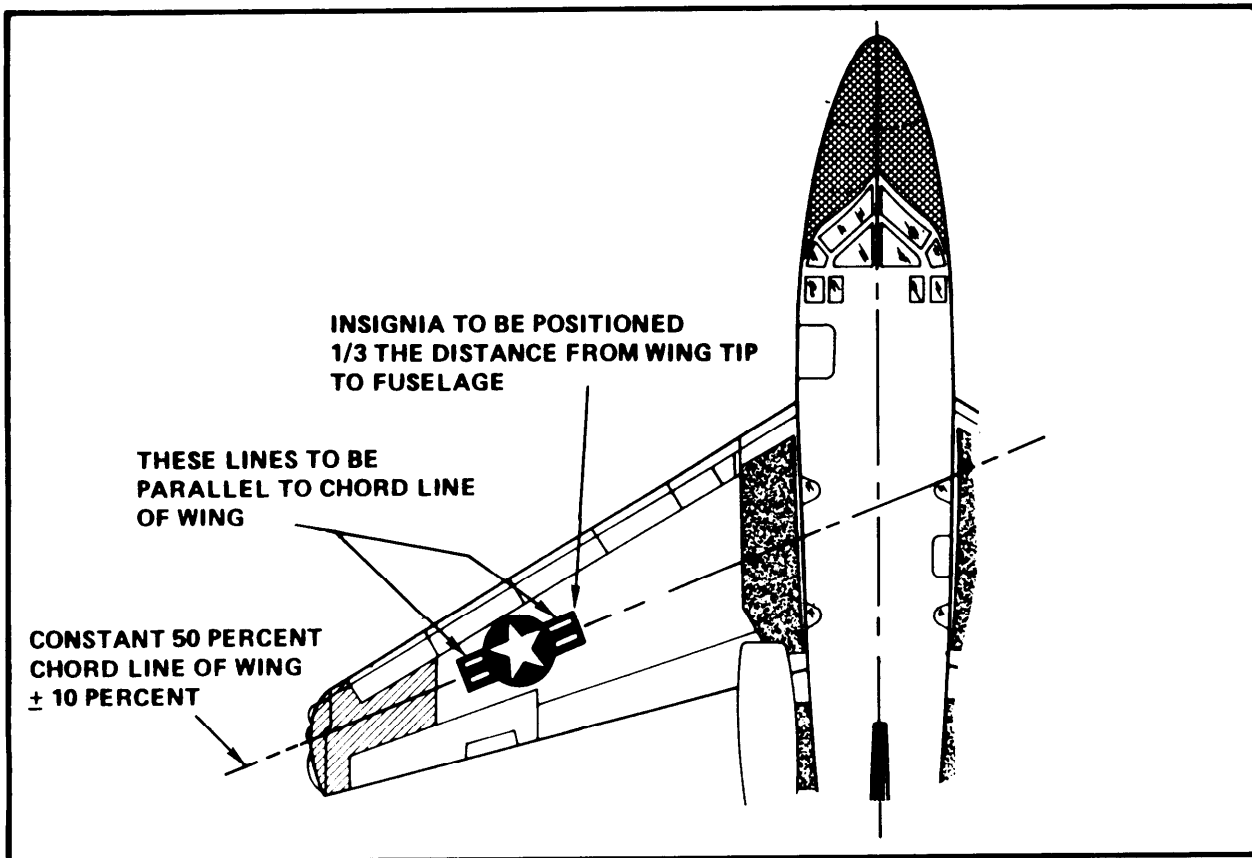


FIGURE A-2. National star insignia on swept wing aircraft.

WHITE BACKGROUND, COLOR NO. 17925



RED, COLOR NO. 11136
LETTERS AND ARROW

FIGURE A-3. Arresting hook warning.

MIL-STD-2161A(AS)

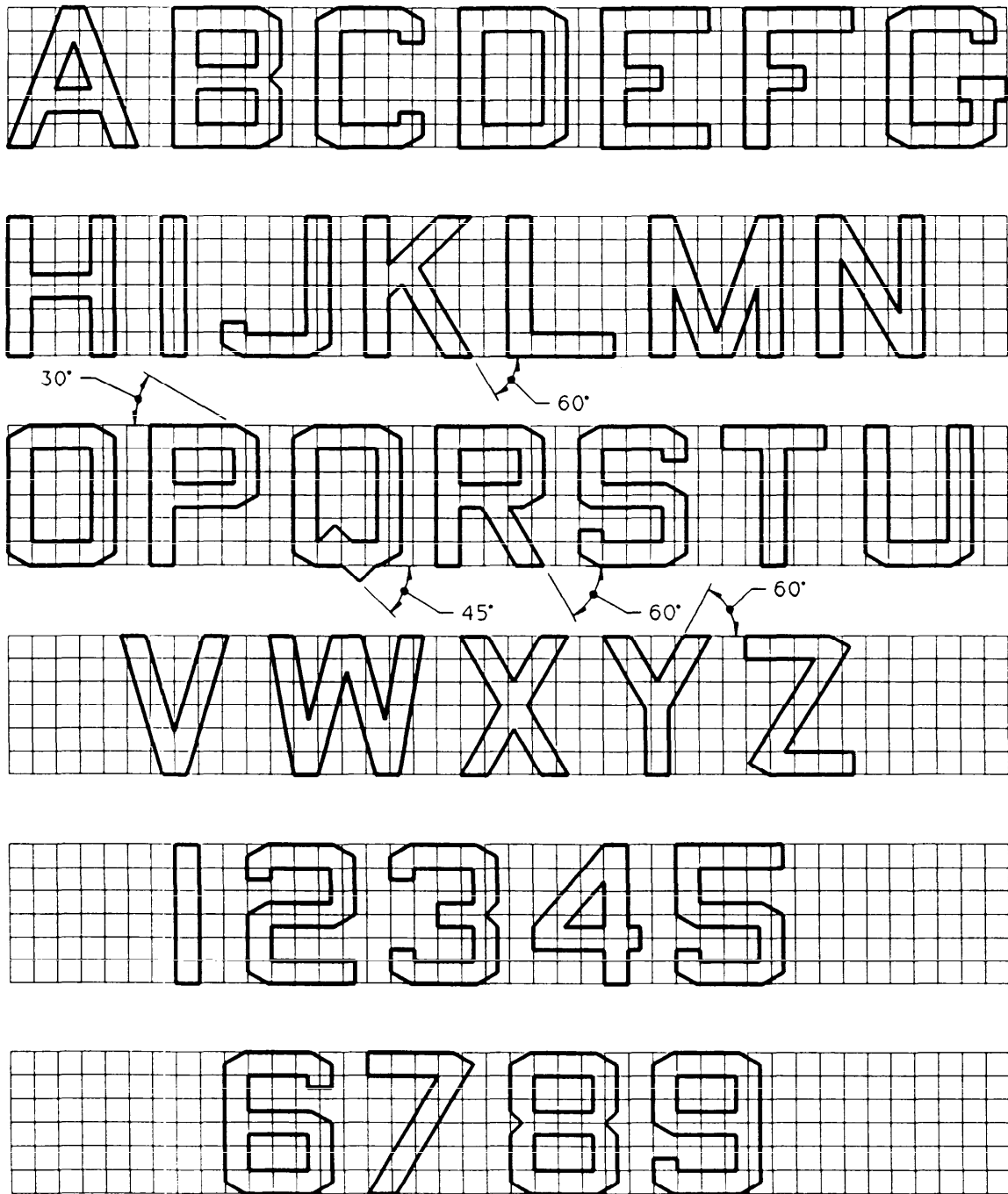


FIGURE A-4. Form of letters and numerals.

MIL-STD-2161A(AS)

1. The width of all letters and numbers (characters) shall be measured between the widest points of the characters.
2. The width of the characters is calculated as a percentage of the height. For example, as on the previous page.
 - a. All letters and numerals are 6 blocks high, and 4.5 blocks wide; therefore, the width of letters and numerals shall be 75 percent of the height.
 - b. The width of letters A and M shall be 92 percent of the letter's height.
 - c. The width of the letter W shall be 108 percent of its height.
 - d. The width of the letter G, with the exception of its overhang on the right side, shall be 75 percent its height.

To obtain the percentage of the height, divide the width of the character by its height.

The sides of the characters containing a corner wedge, (ie. B, C, D, G, 2, 3, etc.), shall be made to include an angle of 30 degrees to the horizontal, as shown on the previous page.

The spacing between characters shall be $1/6$ of the height of the letter or numeral. This spacing shall be measured from the point on each character nearest the other.

The dash (-) character is constructed such that its width is 50 percent of the width of the adjoining characters, and it shall be vertically centered. Spacing of the dash and adjoining characters shall be $1/6$ the height of the adjoining characters.

All overhangs (letters C, G, S and numerals 2, 3, 4, 9) shall be $1/12$ the character's height.

FIGURE A-4. Form of letters and numerals - Continued.

MIL-STD-2161A(AS)

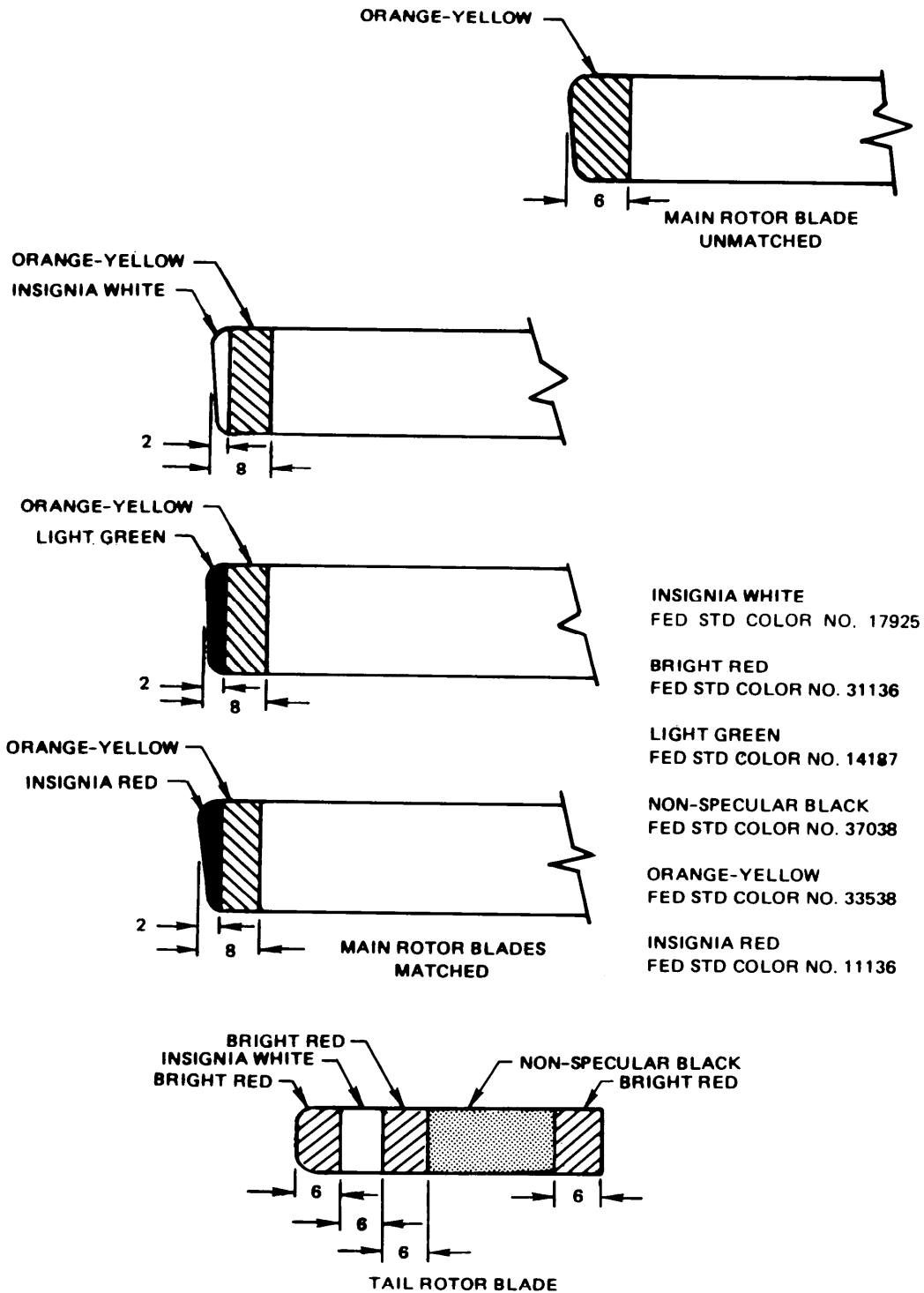


FIGURE A-5. Color scheme for helicopter blades.

MIL-STD-2161A(AS)

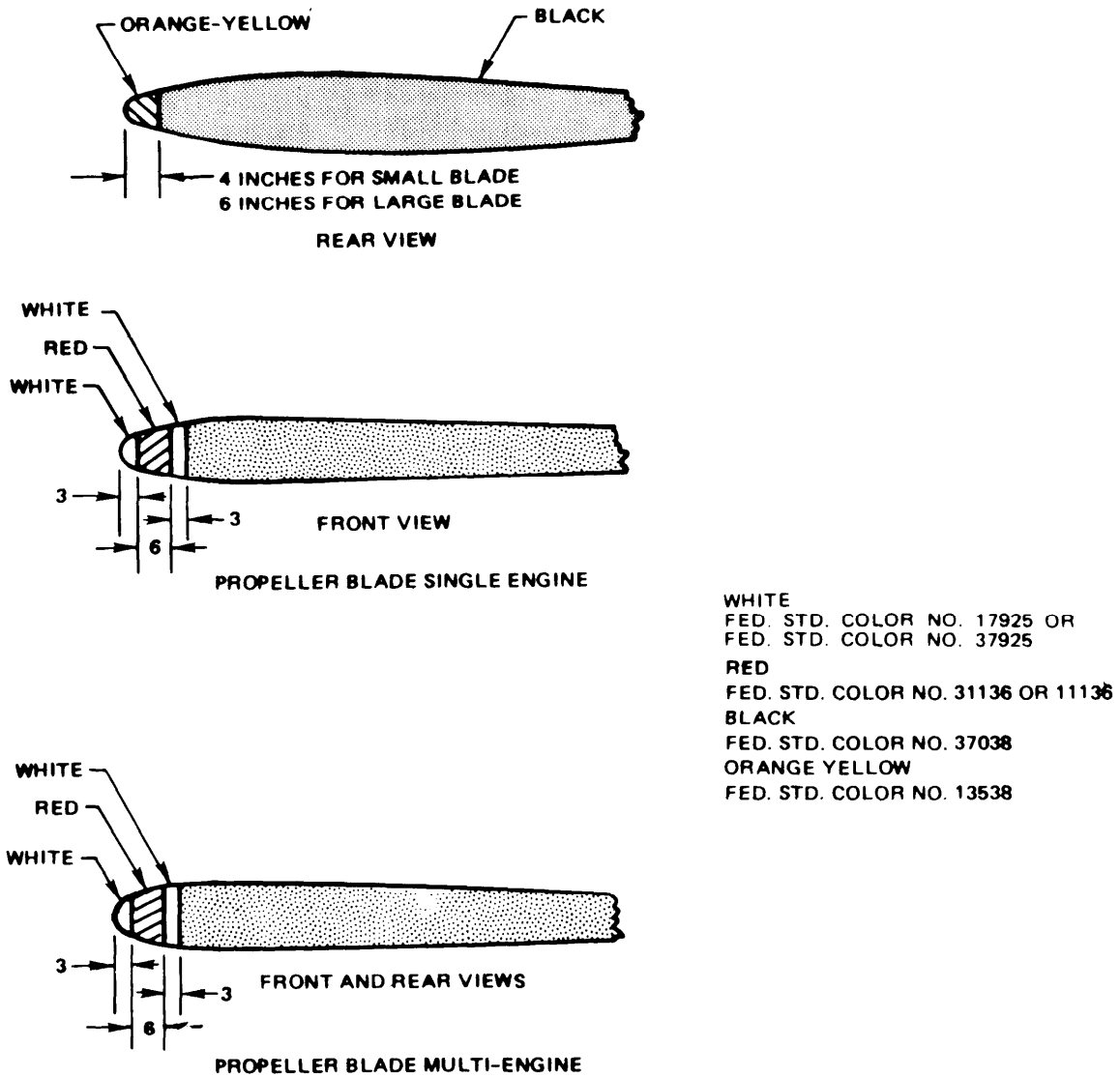


FIGURE A-6. Color scheme for reciprocating single and multi engine aircraft propellers.

MIL-STD-2161A(AS)

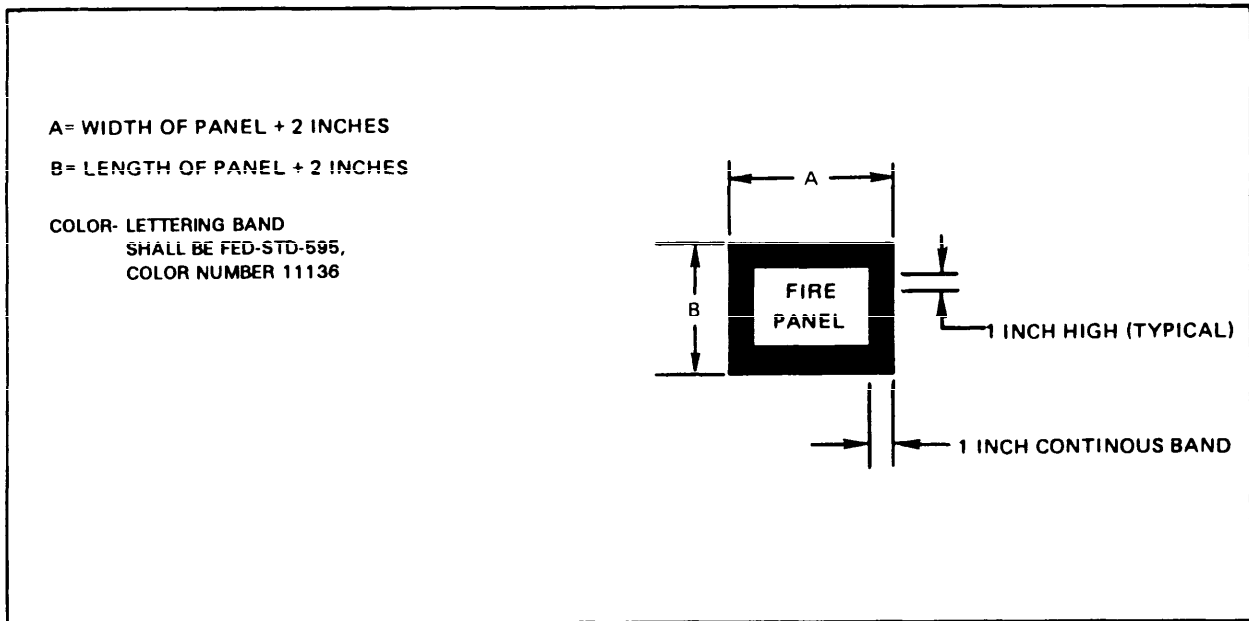


FIGURE A-7. Markings for fire access panel.

MIL-STD-2161A(AS)

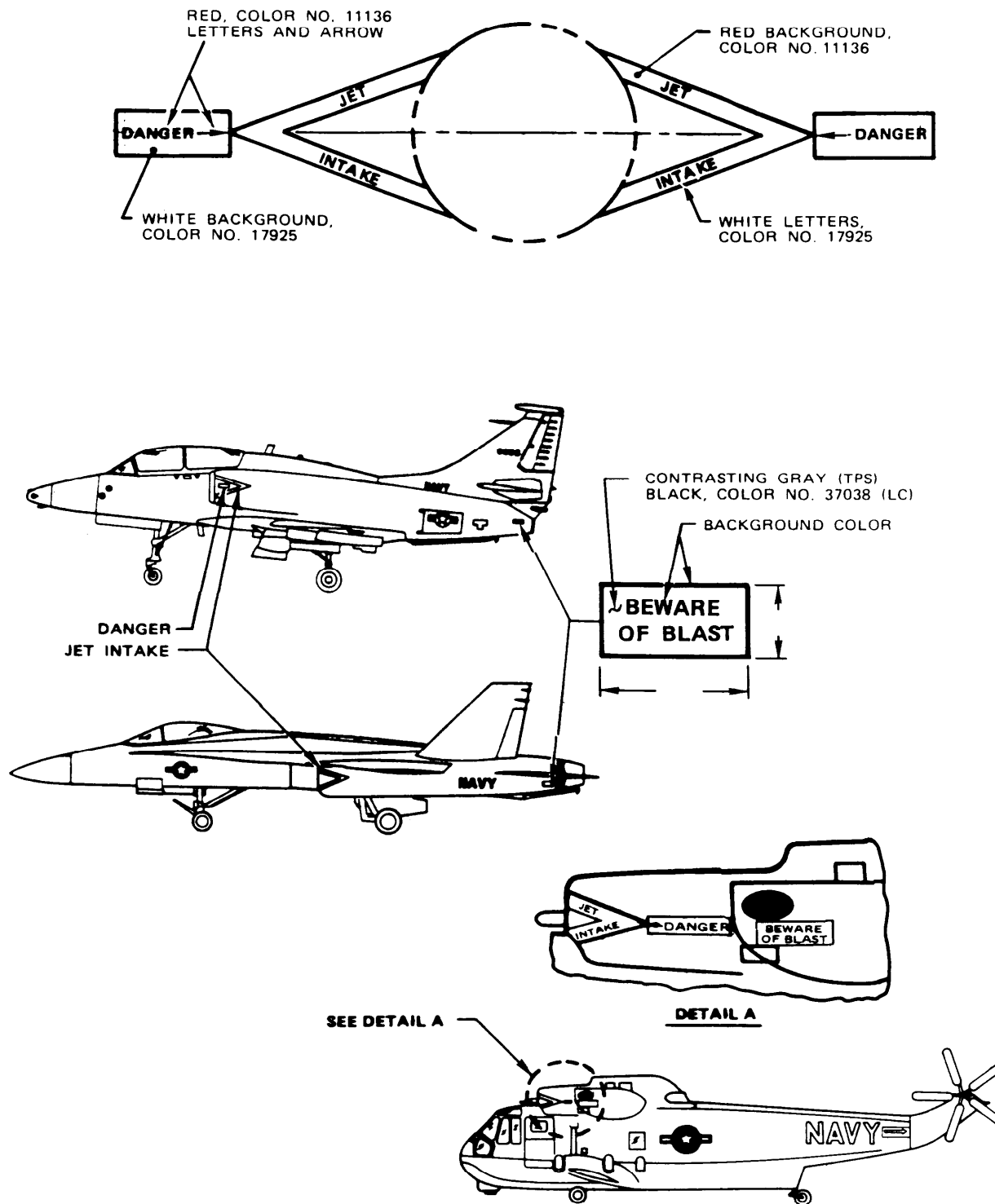
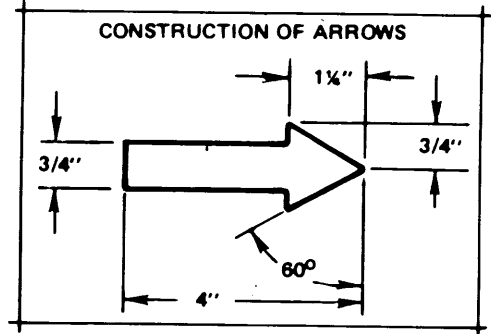


FIGURE A-8. Warning chevron and signs applied adjacent to jet engine intake and exhaust.

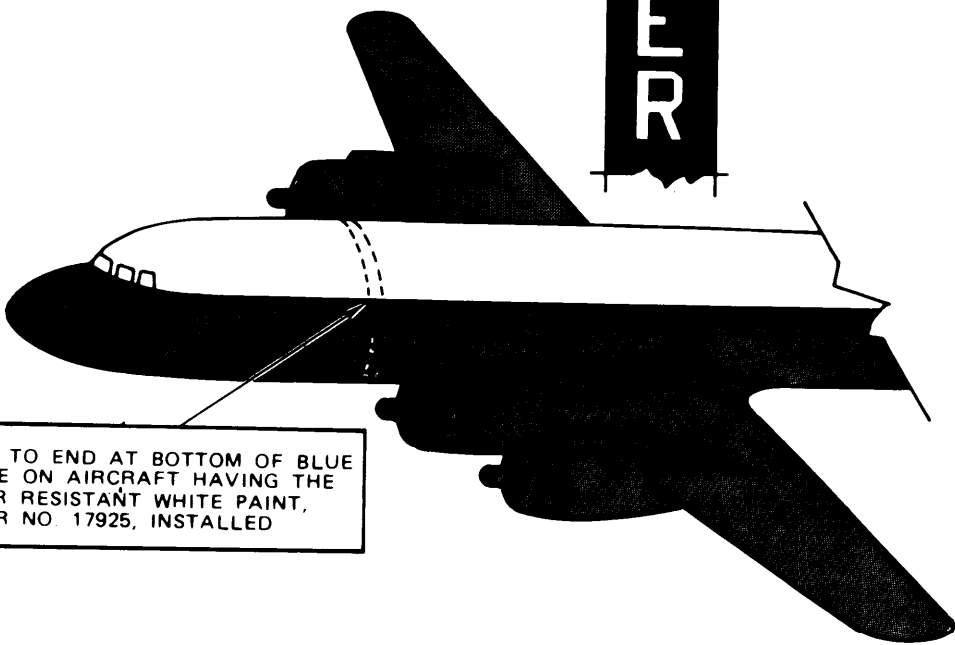
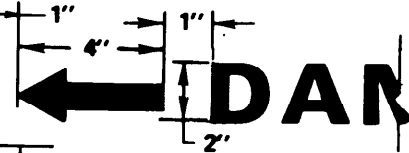
MIL-STD-2161A(AS)

PROPELLER WARNING STRIPES AND SIGNS

INSIGNIA RED, COLOR NO. 11136, CAUTION BAND TO BE 3" WIDE.
 INSIGNIA WHITE, COLOR NO. 17925, LETTERS, SUPERIMPOSED ON BAND, TO BE 2" HIGH.
 INSIGNIA RED, COLOR NO. 11136, WORDS, DANGER, TO BE 2" HIGH.
 INSIGNIA RED, COLOR NO. 11136, ARROWS TO BE 4" LONG.



DANGER →



BAND TO END AT BOTTOM OF BLUE STRIPE ON AIRCRAFT HAVING THE SOLAR RESISTANT WHITE PAINT, COLOR NO. 17925, INSTALLED

FIGURE A-9. Propeller warning strips and signs.

MIL-STD-2161A(AS)

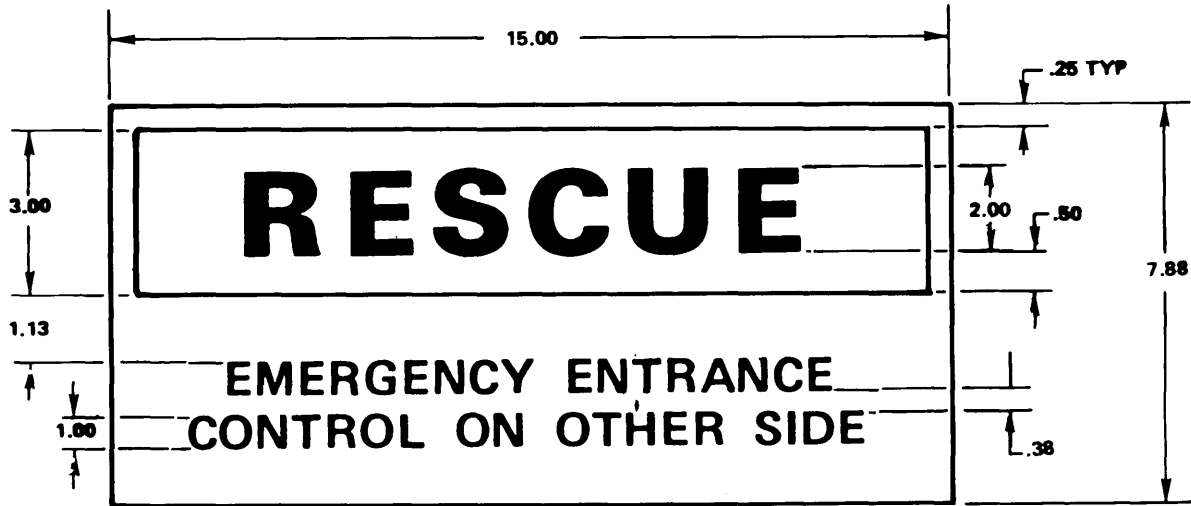


FIGURE A-10. Canopy release location.

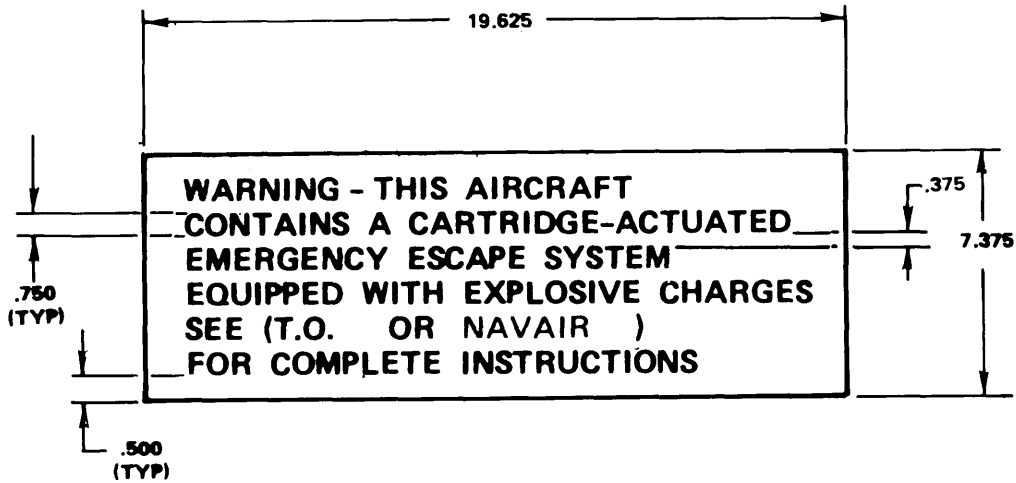


FIGURE A-11. Warning decal.

MIL-STD-2161A(AS)

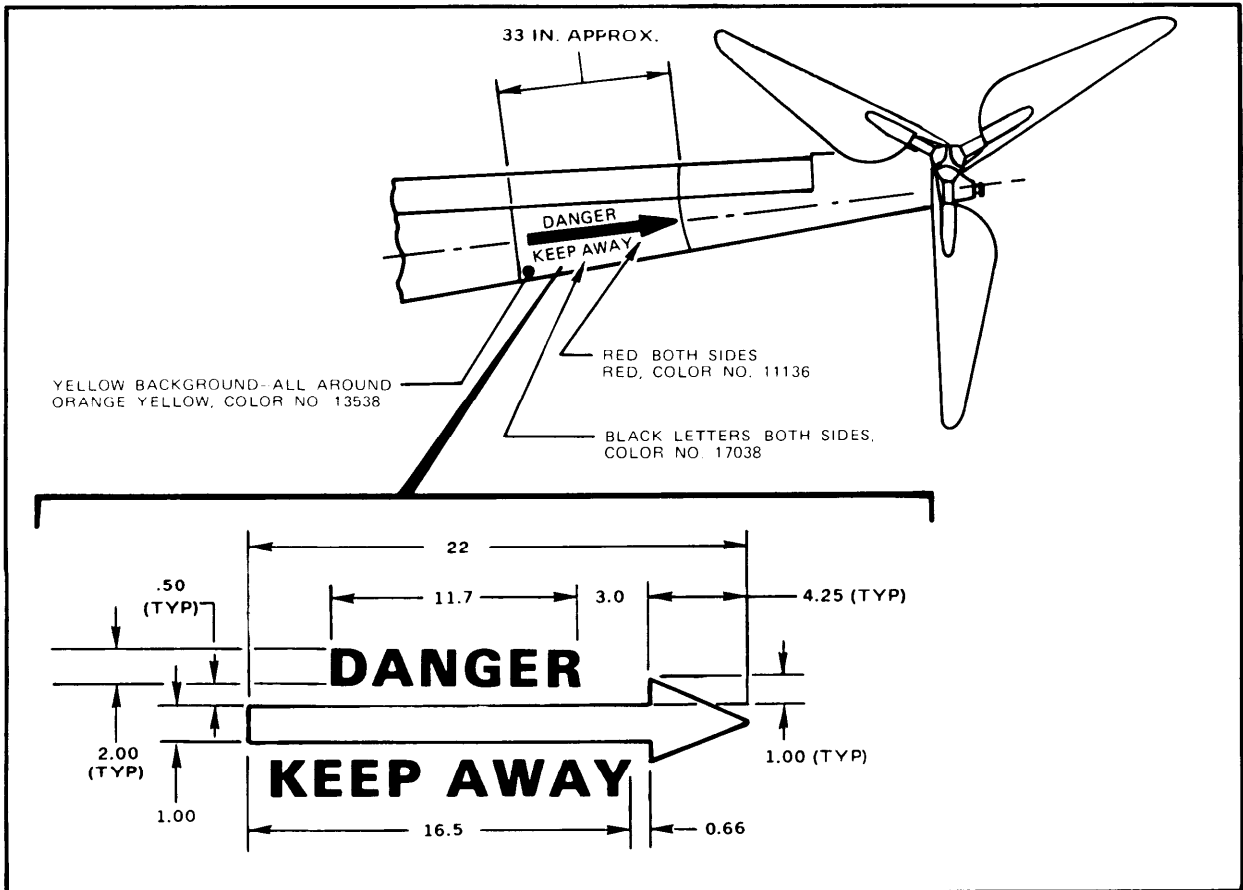
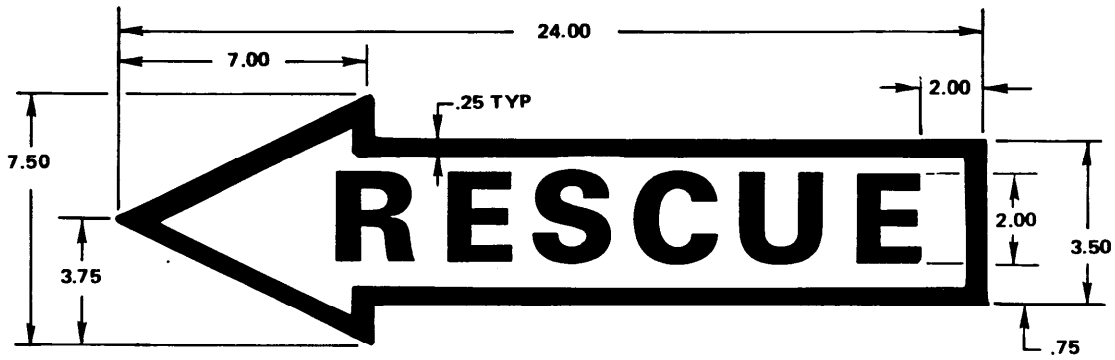


FIGURE A-12. Helicopter tail boom markings.



COLOR: ARROW - ORANGE - YELLOW, COLOR NO. 13538
BORDER AND LETTERS - BLACK, COLOR NO. 17038

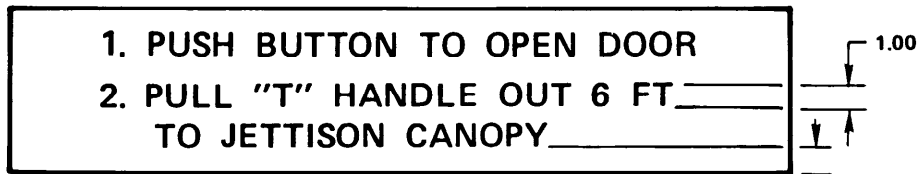


FIGURE A-13. Canopy release markings.

MIL-STD-2161A(AS)

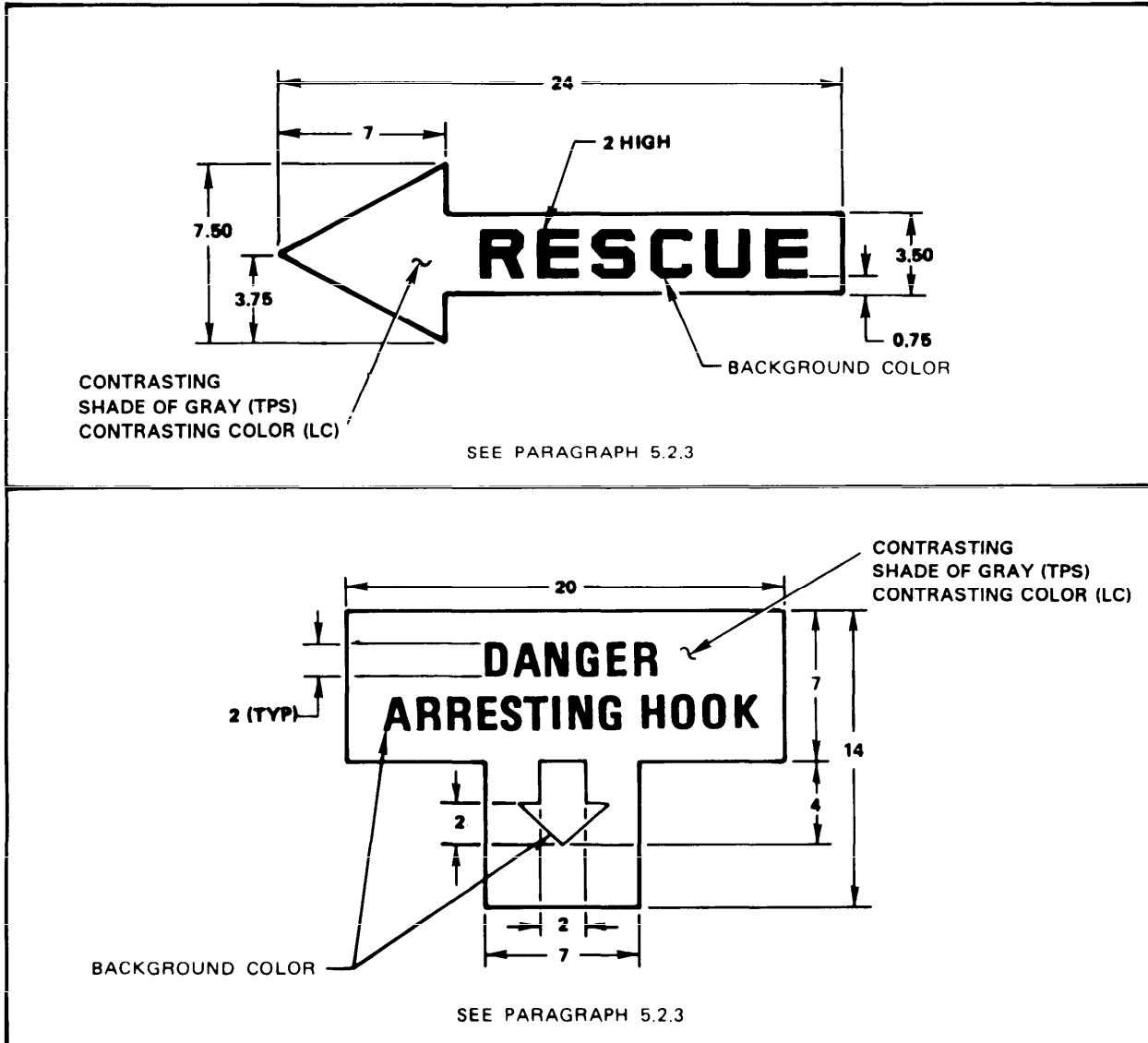


FIGURE A-14. Representative tactical and land camouflage paint scheme markings.

MIL-STD-2161A(AS)

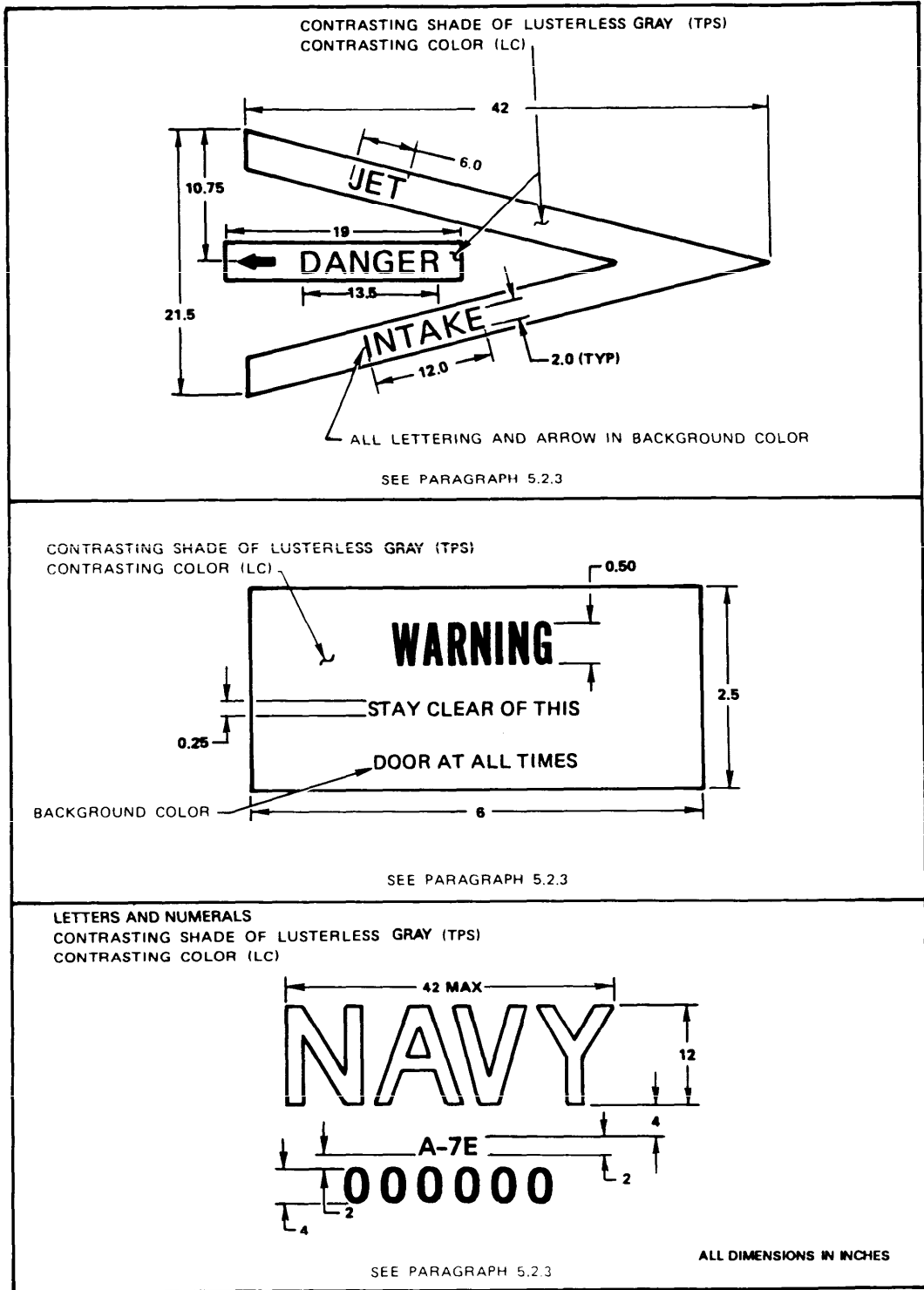


FIGURE A-15. Representative tactical and land camouflage paint scheme markings.

MIL-STD-2161A(AS)

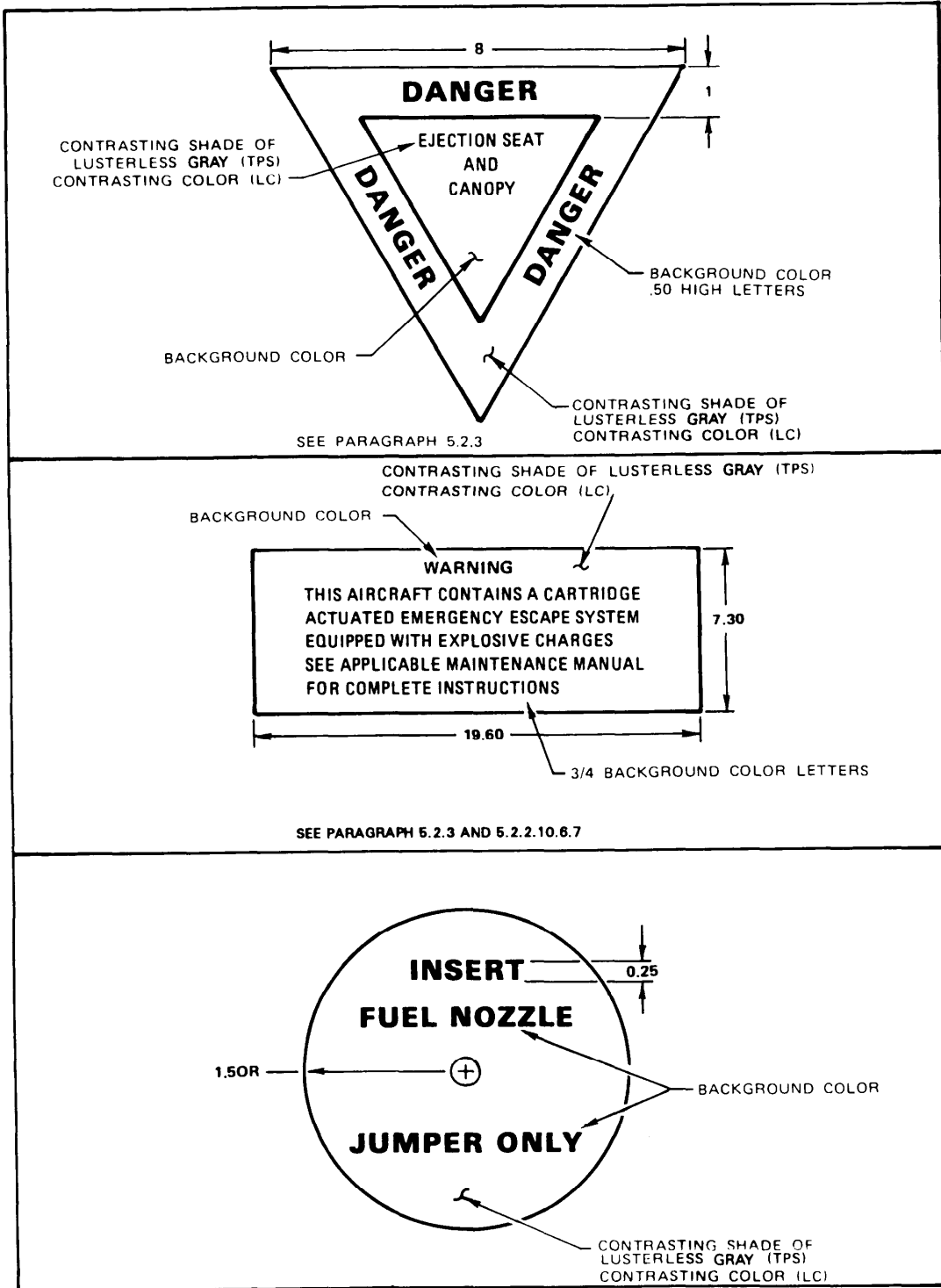
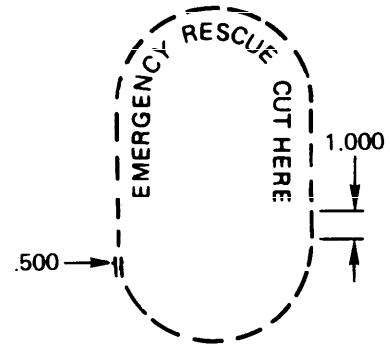
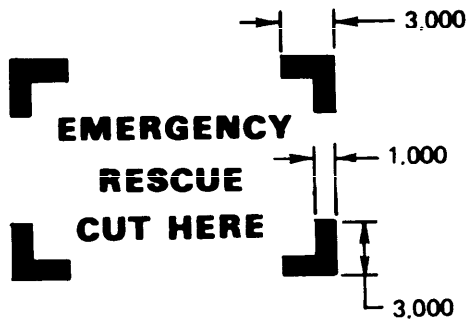


FIGURE A-16. Representative tactical and land camouflage paint scheme markings.

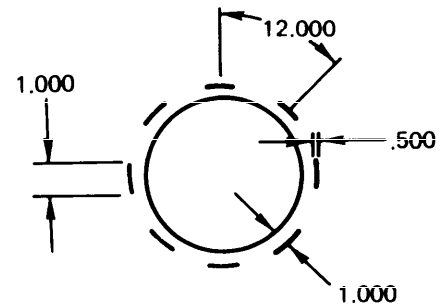
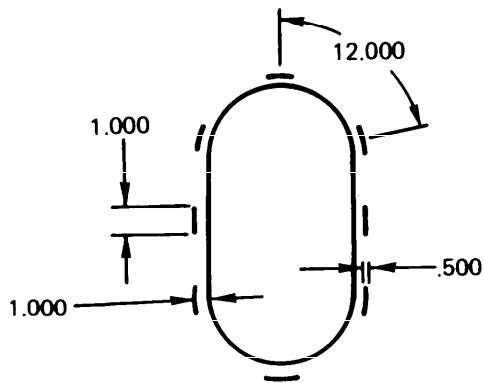
MIL-STD-2161A(AS)



CORNER MARKING
DIMENSIONS IN INCHES

PERIPHERY MARKING

LETTERS SHALL BE A MINIMUM OF 2 INCHES HIGH.



AUXILIARY DOOR

NAVIGATOR'S DOME

DIMENSIONS IN INCHES.

FIGURE A-17. Area cutout markings.

MIL-STD-2161A(AS)

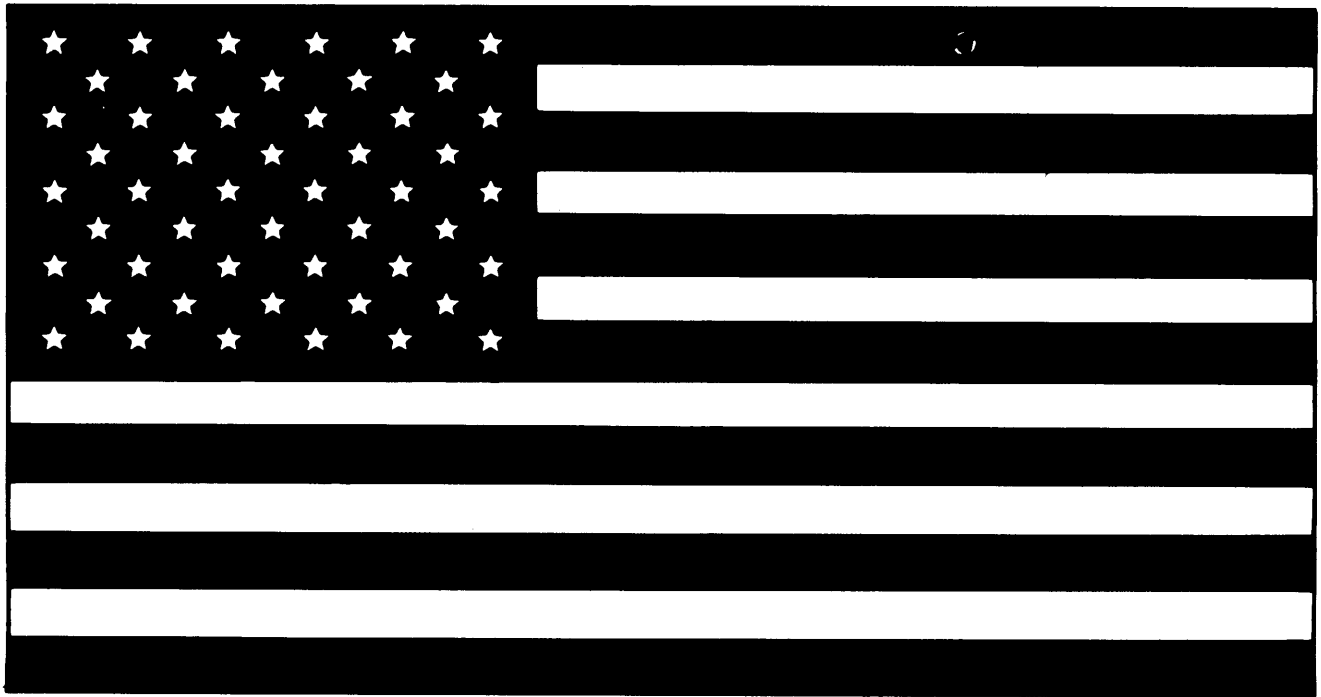
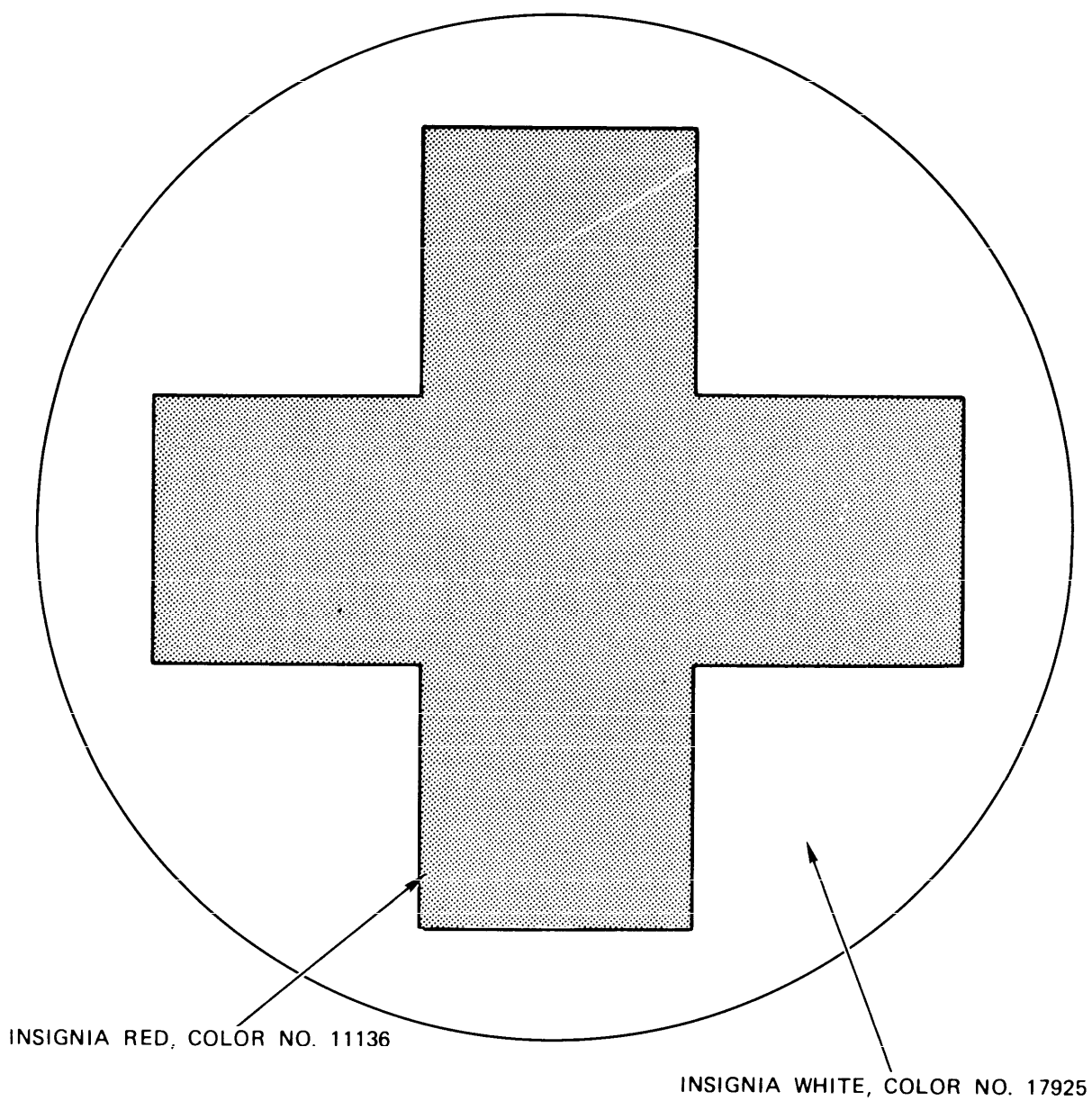


FIGURE A-18. American flag dimensions shall be in accordance with DDD-F-416.

MIL-STD-2161A(AS)



REFER TO PARAGRAPH 5.2.4

FIGURE A-19. Geneva red cross.

MIL-STD-2161A(AS)

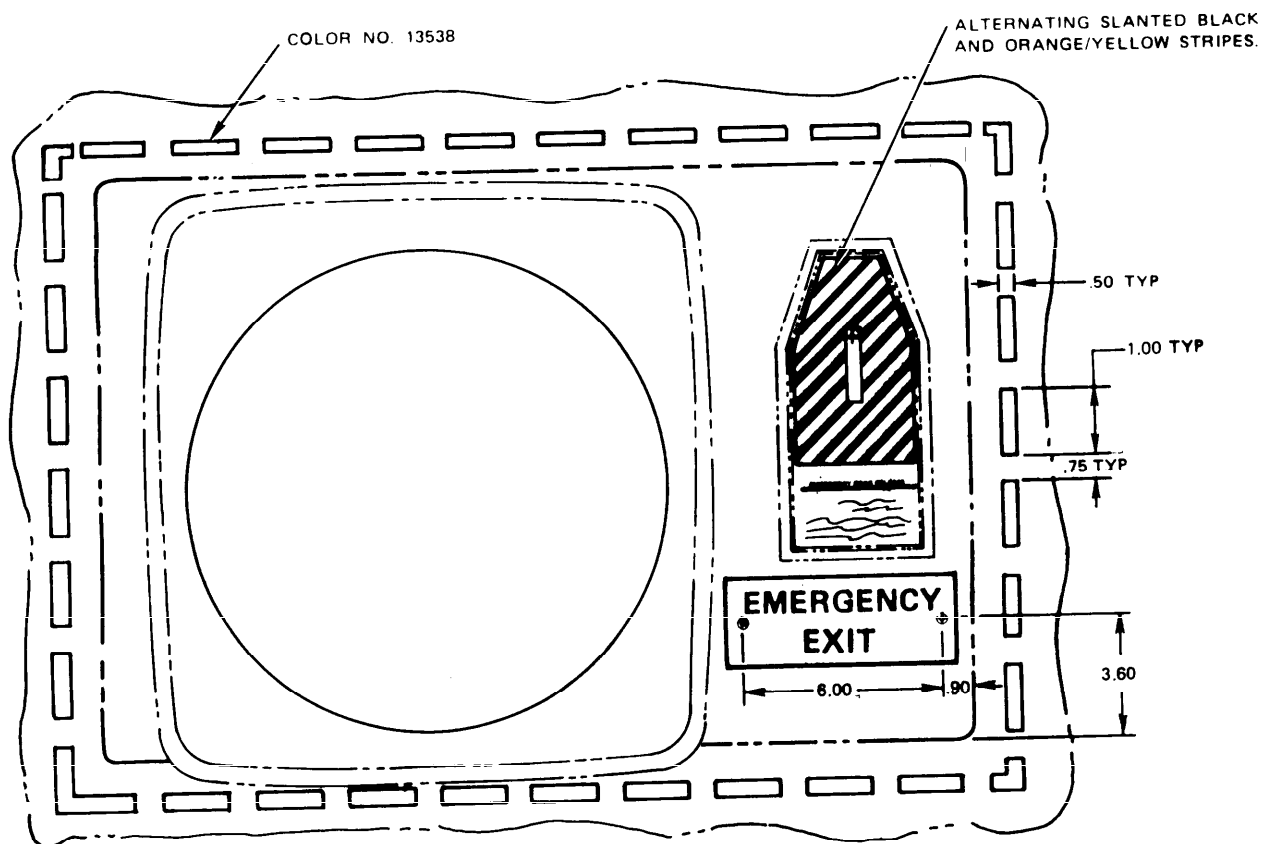


FIGURE A-20. Placard installation-identification, emergency escape hatch.

MIL-STD-2161A(AS)

APPENDIX B

SERVICING, GROUND HANDLING, HAZARD WARNING MARKINGS,
AND ARMAMENT PLACARD FOR AIRCRAFT

10. SCOPE

10.1 Scope. This appendix specifies aircraft servicing markings and appropriate NATO code number for cross servicing. Hazard warning markings for ground handling are included.

10.2 Use. This Appendix is a mandatory part of this standard. The information contained herein is intended for compliance.

20. APPLICABLE DOCUMENTS

20.1 Government documents.

20.1.1 Specifications and standards. The following specifications and standards form a part of this document to the extent specified herein. Unless otherwise specified, the issues of these documents are those listed in the issue of the Department of Defense Index of Specifications and Standards (DODISS) and supplement thereto, cited in the solicitation.

SPECIFICATIONS

FEDERAL

L-S-300	-	Sheeting and Tape, Reflective: Nonexposed Lens
O-E-760	-	Ethyl Alcohol (Ethanol), Denatured Alcohol, Proprietary Solvents and Special Industrial Solvents
O-M-232	-	Methanol (Methyl Alcohol)
SS-G-659	-	Graphite, Dry (Lubricating)
TT-I-735	-	Isopropyl Alcohol
TT-S-1732	-	Sealing Compound, Pipe Joint and Thread, Lead Free, General Purpose
VV-P-236	-	Petrolatum, Technical

MIL-STD-2161A(AS)

MILITARY

MIL-C-4339	-	Corrosion Preventive, Soluble Oil for Water Injection Systems
MIL-G-4343	-	Grease, Pneumatic System
MIL-T-5544	-	Thread Compound, Antiseize, Graphite Petrolatum
MIL-C-5545	-	Corrosion Preventive, Aircraft Engine, Heavy Oil Type
MIL-H-5606	-	Hydraulic Fluid, Petroleum Base, Aircraft, Missile and Ordnance
MIL-T-5624	-	Turbine Fuel, Aviation, Grades JP-4, JP-5 and JP-5/JP-8 ST
MIL-G-6032	-	Grease, Plug Valve, Gasoline and Oil Resistant, NATO Code Number G-363
MIL-L-6081	-	Lubrication Oil, Jet Engine
MIL-L-6082	-	Lubricating Oil, Aircraft Piston Engine (Non-Dispersant Mineral Oil)
MIL-H-6083	-	Hydraulic Fluid, Petroleum Base, for Preservation and Operation
MIL-L-6085	-	Lubricating Oil: Instrument, Aircraft, Low Volatility
MIL-L-6086	-	Lubricating Oil, Gear, Petroleum Base
MIL-C-6529	-	Corrosion Preventive, Aircraft Engine
MIL-L-7808	-	Lubricating Oil, Aircraft Turbine Engine, Synthetic Base, NATO Code O-148
MIL-M-7866	-	Molybdenum Disulfide, Technical, Lubrication Grade
MIL-L-7870	-	Lubricating Oil, General Purpose, Low Temperature
MIL-C-8188	-	Corrosion-Preventive Oil, Gas Turbine Engine, Aircraft, Synthetic Base
MIL-A-8243	-	Anti-Icing and Deicing-Defrosting Fluids

MIL-STD-2161A(AS)

MIL-S-8660	-	Silicone Compound, NATO Code Number S-736
MIL-C-11796	-	Corrosion Preventive Compound, Petrolatum, Hot Application
MIL-C-16173	-	Corrosion Preventive Compound, Solvent Cutback, Cold Application
MIL-G-21164	-	Grease, Molybdenum Disulfide, for Low and High Temperatures NATO Code G-353
MIL-L-22851	-	Lubricating Oil, Aircraft Piston Engines (Ashless Dispersant)
MIL-L-23398	-	Lubricant, Solid Film, Air Cured, Corrosion Inhibiting, NATO Code Number S-749
MIL-L-23699	-	Lubricating Oil, Aircraft Turbine Engine, Synthetic Base, NATO Code Number O-156
MIL-G-23827	-	Grease, Aircraft and Instrument, Gear and Actuator Screw, NATO Code Number G-354
MIL-G-25013	-	Grease, Aircraft, Ball and Roller Bearing NATO Code Number G-372
MIL-G-25537	-	Grease, Aircraft, Helicopter, Oscillating Bearing, NATO Code Number G-366, Metric
DOD-L-25681	-	Lubricant, Molybdenum Disulfide, Silicone
MIL-I-27686	-	Inhibitor, Icing, Fuel System
MIL-T-27730	-	Tape, Antiseize, Polytetrafluoroethylene, with Dispenser
MIL-P-38477	-	Plastic Material, Pressure Sensitive Adhesive for Aircraft Identification and Marking
MIL-M-43719	-	Marking Materials and Markers, Adhesive Elastomeric, Pigmented, General Specification for
MIL-L-46010	-	Lubricant, Solid Film, Heat Cured, Corrosion Inhibiting
MIL-H-46170	-	Hydraulic Fluid, Rust Inhibited, Fire Resistant, Synthetic Hydrocarbon Base

MIL-STD-2161A(AS)

- MIL-G-81322 - Grease, Aircraft, General Purpose, Wide Temperature Range
- MIL-L-81329 - Lubricant, Solid Film, Extreme Environment, NATO Code Number S-1737, Metric
- MIL-T-83133 - Turbine Fuels, Aviation, Kerosene Types, NATO F-34 (JP-8) & F-35
- MIL-H-83282 - Hydraulic Fluid, Fire Resistant, Synthetic Hydrocarbon Base, Aircraft, Metric, NATO Code Number H-537
- MIL-G-83363 - Grease, Transmission, Helicopter
- MIL-I-85470 - Inhibitor, Icing, Fuel System, High Flash, NATO Code Number S-1745

STANDARDS**FEDERAL**

- FED-STD-595 - Colors Used in Government Procurement

(Unless otherwise indicated, copies of federal and military specifications, standards, and handbooks are available from the Standardization Documents Order Desk, Building 4D, 700 Robbins Avenue, Philadelphia, PA 19111-5094.)

20.1.2 Other Government publications. The following other government publications form a part of this Appendix to the extent specified herein. Unless otherwise specified, the issue shall be those in effect on the date of the solicitation.

PUBLICATIONS**AIR STANDARDIZATION COORDINATING COMMITTEE (ASCC)**

- AIR STD 15/1 - Interchangeability Chart of Standardized Aviation Fuels, Lubricants, and Allied Products
- AIR STD 25/1 - Pressure Replenishment Connections for Engine Lubricating Oil
- AIR STD 25/3A - Aircraft Servicing/Hazard Markings

MIL-STD-2161A(AS)

NORTH ATLANTIC TREATY ORGANIZATION (NATO)

- STANAG 1135 - Interchangeability Chart of NATO Standardized Fuels, Lubricants and Associated Products
- STANAG 3109 - Symbol Marking of Aircraft Servicing and Safety/Hazard Points

20.2 Non-Government publications. The following document forms a part of this specification to the extent specified herein. Unless otherwise specified, the issues of the documents which are Department of Defense (DOD) adopted are those listed in the issue of the DODISS cited in the solicitation. Unless otherwise specified, the issues of the documents not listed in the DODISS are the issue of the documents cited in the solicitation.

AMERICAN SOCIETY FOR TESTING AND MATERIALS (ASTM)

- ASTM D910 - Standard Specification for Aviation Gasolines

(Application for copies should be addressed to American Society for Testing and Materials, 1916 Race Street, Philadelphia, PA 19103-1187.)

(Non-Government standards and other publications are normally available from the organizations that prepare or distribute the documents. These documents also may be available in or through libraries or other informational services.)

20.3 Order of precedence. In the event of a conflict between the text of this document and the references cited herein (except for related associated detail specifications, specification sheets or MS standards), the text of this document shall take precedence. Nothing in this document, however, supersedes applicable laws and regulations unless a specific exemption has been obtained.

30. DEFINITIONS

30.1 Definitions. For purposes of this Appendix, the definitions of this standard shall apply.

40. GENERAL REQUIREMENTS

40.1 Servicing and precautioning marking. The servicing and precautionary markings for aircraft shall be in accordance with the symbols shown and as described herein. Symbols shall be approximately 4 inches in the lowest dimension, except where otherwise specified. However, smaller sized lettering which supplement the symbols may be used if required by the item or area to be marked. Lettering which supplements the symbols shall be in the scale 1 to 4 in relation to the symbol (see figure B-1).

MIL-STD-2161A(AS)

40.2 Servicing instructions. Servicing instructions for hydraulic systems, hydraulic reservoirs, landing gear shock struts, wheels and tires, and pneumatic systems shall be provided on instruction plates or on a permanent and legible manner adjacent to charging points and test connections. Access doors or panels to servicing points shall be marked with the appropriate servicing symbol(s).

40.3 Service warning markings. Service markings shall be used to give warning and minimize possible errors in servicing, handling or aircraft and safety of flight. Symbols approved by international agreement shall be displayed on all "in production" and "in service" aircraft. These symbols shall be in accordance with those shown on figures B-6 and B-7. Marking for trainer and liaison aircraft shall be included. Paint or decals may be used when applying service point identification and precautionary service markings. Decalcomanias shall be in accordance with MIL-M-43719, L-S-300, ASCC AIR STD 25/3A and plastic material per MIL-P-38477.

40.4 Printed information. Information required in connection with servicing symbols shall be printed in accordance with 5.2.5.1, unless otherwise specified by the procuring activity.

40.5 Colors. Colors for ground handling, hazard warning, filling, and atomic flash markings shall be as follows:

- a. Ground handling: The servicing symbols used to mark ground handling servicing points shall be aviation yellow, FED-STD-595, color number 13538.
- b. Hazard: Hazard symbols shall be insignia red, FED-STD-595, color number 11136.
- c. Filling Points: The servicing symbols used to mark filling points shall be colored in black, FED-STD-595, color number 17038 or insignia white, FED-STD-595, color number 17925, according to the background.
- d. Atomic flash: Aircraft which may be subjected to atomic flash, will have servicing markings painted in suitable pale colors, having a reflectivity of at least 50 percent.

40.6 International standardization. Certain provisions of this standard are the subject of international standardization agreements ASCC AIR STD 25/1, ASCC AIR STD 15/1, NATO STANAG 3109, and NATO STANAG 1135. When revision or cancellation of this standard is proposed which will modify the international agreement concerned, the preparing activity will take appropriate action through international standardization channels including departmental standardization offices, to change the agreement or make other appropriate accommodations.

MIL-STD-2161A(AS)

50. DETAIL REQUIREMENTS

50.1 Aircraft markings and placard. The following figures illustrate aircraft armament placards, NATO codes and markings, ground handling and hazards and NATO code numbers for cross servicing.

MIL-STD-2161A(AS)

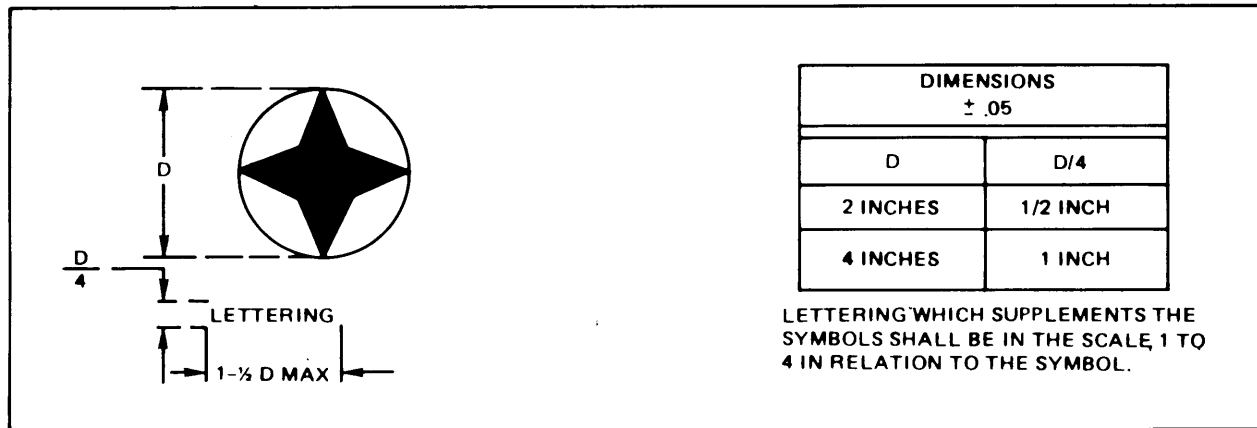


FIGURE B-1. Typical symbol dimensioning.

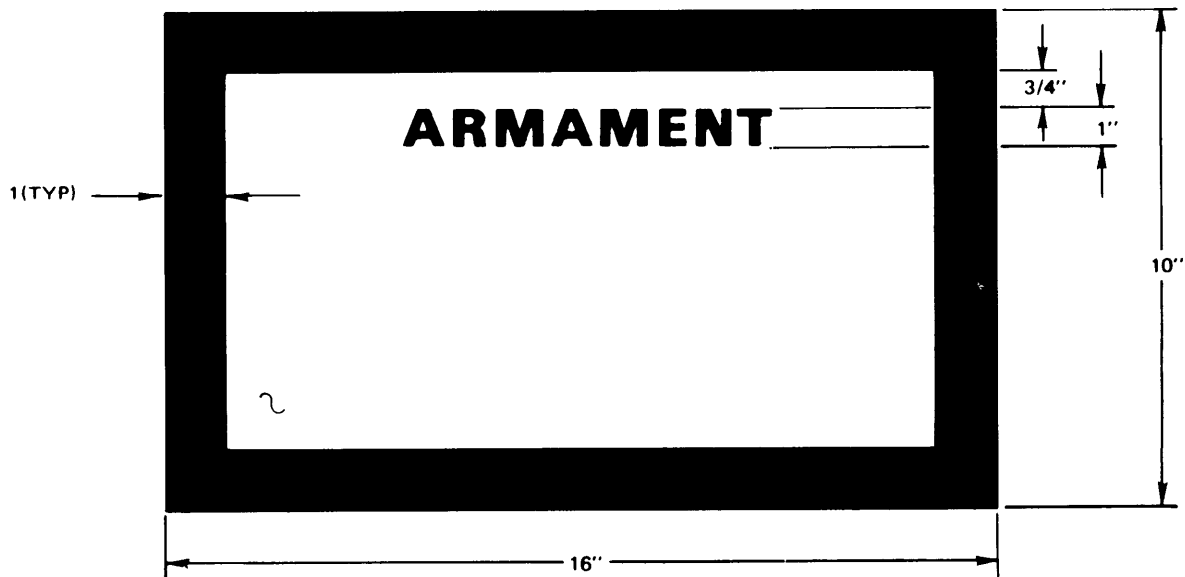





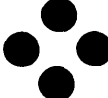












FIGURE B-2. Armament placard.


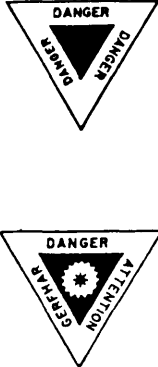

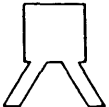
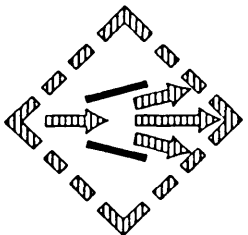

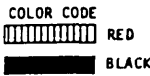

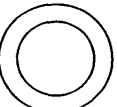

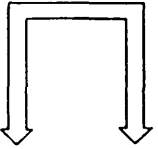

MIL-STD-2161A(AS)

FILLING (a)	
FUELING FILLED FOUR POINTED STAR WITH NOTATION OF NATO CODE NUMBER FOR FUEL  (NATO CODE NO.)	OXYGEN (BREATHING) TWO HORIZONTAL FILLED RECTANGLES WITH NOTATION OF EITHER "GAS" OR "LIQUID" FOR GASEOUS OXYGEN INCLUDE CHARGING PRESSURES IN ENGLISH AND METRIC UNITS. FOR LIQUID OXYGEN INCLUDE CAPACITY IN LITRES. WHEN NECESSARY 
ROCKET FUELS FILLED FOUR POINTED STAR IN CRESCENT WITH NOTATION OF NATO CODE NUMBER FOR ROCKET FUEL  (NATO CODE NO.)	ANTI-DETONANT OR THRUST AUGMENTATION FILLED CHEVRON WITH NOTATION OF NATO CODE NUMBER  (NATO CODE NO.)
ROCKET OXIDIZER FILLED CRESCENT WITH NOTATION OF NATO CODE NUMBER FOR ROCKET OXIDIZER  (NATO CODE NO.)	AIR CONDITIONING DOT PATTERN 
ENGINE LUBRICATING OIL FILLED SQUARE WITH NOTATION OF NATO CODE NUMBER FOR ENGINE LUBRICATING OIL  (NATO CODE NO.)	NITROGEN SERVICES FILLED SQUARE WITH A QUARTER ARC REMOVED FROM EACH CORNER, WITH TYPE OF GAS USED AND PRESSURE IN ENGLISH AND METRIC UNITS  NITROGEN — psi — Kg/Cm ²
HYDRAULIC FLUID FILLED CIRCLE WITH NOTATION OF NATO CODE NUMBER FOR HYDRAULIC FLUID  (NATO CODE NO.)	FIRE EXTINGUISHING SYSTEM A FILLED DIAMOND WITH NOTATION SHOWING NATO CODE NUMBER  (NATO CODE NO.)
DE-ICING FILLED TRIANGLE WITH NOTATION OF NATO CODE NUMBER FOR DE-ICING FLUID  (NATO CODE NO.)	EXTERNAL ELECTRICAL CONNECTIONS FILLED "E" WITH LOWER LIMB SHORTENED STATING SERVICE AND VOLTAGE DETAILS  SERVING STARTING ETC. 28V OR 112 V DC 115/200V, 400 CYCLES
COOLANT TWO FILLED HORIZONTAL S's WITH NOTATION OF NATO CODE NUMBER FOR COOLANT AND PERCENTAGE COMPOSITION IF NECESSARY  (NATO CODE NO.) WATER _____ % SOLUBLE OIL _____ %	GROUNDING OR EARTHING RECEPTACLE A FILLED INVERTED "T" WITH TWO PARALLEL BARS UNDERNEATH WHICH DIMINISH IN SIZE  GROUND (EARTH) HERE
PNEUMATIC SYSTEM FILLED X WITH NOTATION OF MAXIMUM CHARGING PRESSURE IN ENGLISH AND METRIC UNITS  MAXIMUM — psi — Kg/Cm ²	INSPECTION OF BATTERY A FILLED ELECTRIC FLASH SIGN 

(a) COLOR - BLACK OR WHITE ACCORDING TO BACKGROUND.

FIGURE B-3. NATO codes and markings-filling.

MIL-STD-2161A(AS)

FILLING COLOR - BLACK OR WHITE ACCORDING TO BACKGROUND		HAZARD (b) COLOR - RED #11136	
PNEUMATIC STARTER CONNECTION	A FILLED X CIRCUMSCRIBED BY A FILLED RING  — PSI — kPa	EXPLOSIVE ACTUATED DEVICES	MARK BOTH SIDES OF FUSELAGE RED FILLED EQUILATERAL TRIANGLE, APEX DOWN, OF THE LARGEST PRACTICABLE SIZE UP TO A 9 INCH (23cm) SIZE TO BE APPLIED TO THE EXTERNAL PART OF AIRCRAFT ADJACENT TO THE EXPLOSIVE DEVICE. THE WORD "DANGER" TO BE WITH ITS TOP TO A SURROUNDING PERIPHERAL RED LINE. IT IS PERMISSIBLE FOR THE WORD "DANGER" TO BE APPLIED IN ANY 3 DIFFERENT LANGUAGES, PROVIDED THAT ENGLISH IS ONE OF THEM. THE WORDS "EJECTION SEAT", "CANOPY" ETC OR AN APPROPRIATE SYMBOL MAY BE ADDED IN WHITE ON THE CENTRAL RED TRIANGLE. 
REFRIGERANT REPLENISHMENT	TWO FILLED TRIANGLES WITH APEXES JOINED ON HORIZONTAL CENTER LINE WITH NOTATION SHOWING TYPE OF REFRIGERANT 		
GROUND HANDLING (b) COLOR AVIATION - YELLOW #13538			
JACKING POINT	AVIATION YELLOW FILLED SQUARE WITH TWO SLANTING LEGS ON BOTTOM SIDE 	AIRBORNE AUXILIARY TURBINE POWER PLANT INLET AND/OR EXHAUST	
SLINGING OR HOISTING POINTS	AVIATION YELLOW FILLED HOOK ON A HORIZONTAL LINE. 	COLOR CODE 	
MOORING OR PICKETING	AVIATION YELLOW FILLED ANCHOR 		
TOWING (c)	AVIATION YELLOW FILLED RING 	CANOPY EXPLOSIVE RELEASE	SYMBOL AS SHOWN IN RED ON EXTERNAL PART OF THE AIRCRAFT ADJACENT TO THE EXPLOSIVE RELEASE 
LIFTING AREA (EXTERNAL STORES)	FILLED HORIZONTAL BAR WITH DOWNWARD POINTING ARROWS AT EACH END OF THE BAR 	OPTIONAL - WHEN USED SHALL BE ADDITIONAL TO HAZARD: EXPLOSIVE ACTUATED DEVICES. 	

(b) OUTLINE SYMBOLS IN BLACK OR WHITE ACCORDING TO THE BACKGROUND.
(c) OPTIONAL WHERE TOWING POINT IS OBVIOUS AND SUITABLE LOCATION FOR SYMBOL IS NOT AVAILABLE.

FIGURE B-4. NATO codes and markings-filling, ground handling and hazards.

MIL-STD-2161A(AS)

NATO SYMBOL OR CODE NUMBER
FOR MILITARY SPECIFICATIONS

CROSS SERVICING OF AIRCRAFT

<u>General type of product</u>	<u>NATO no. 1/</u>	<u>Applicable specification 2/</u>
I. <u>Piston engine fuels</u>		
II. <u>Turbine engine fuels</u>		
Kerosene type, high flashpoint	F-44	MIL-T-5624
Gasoline type, wide cut (JP-4)	F-40	MIL-T-5624
Aviation, kerosene type (JP-8)	F-34	MIL-T-83133
Kerosene type	F-35	MIL-T-83133
III. <u>Starter fuels</u>		
IV. <u>Thrust augmentation fluids</u>		
Methanol	S-747	O-M-232 Grade A
Soluble oil	C-630	MIL-C-4339
V. <u>Piston engine oils</u>		
Non-dispersant mineral oil	O-117	MIL-L-6082 Grade 1100
Non-dispersant mineral oil	O-113	MIL-L-6082 Grade 1065
Ashless dispersant	O-128	MIL-L-22851 Type II
Ashless dispersant	O-123	MIL-L-22851 Type III

FIGURE B-5. NATO code number cross reference.

MIL-STD-2161A(AS)

	<u>General type of product</u>	<u>NATO no. 1/</u>	<u>Applicable specification 2/</u>
VI.	<u>Turbine engine oils</u>		
	Aircraft turbine lubricating oil	O-133	MIL-O-6081 Grade 1010
	Synthetic type 3cSt	O-148	MIL-L-7808
	Synthetic type 5cSt	O-156	MIL-L-23699
VII.	<u>Aviation greases</u>		
	Grease, molybdenum disulfide, high & low temperatures	G-353	MIL-G-21164
	General purpose 3/	G-382	
	High temperature 3/	G-359	
	Ball and roller bearing wide temperature range 3/	G-359	
	Extreme pressure synthetic	G-354	MIL-G-23827
	Hydrocarbon resistant	G-363	MIL-G-6032
	Pneumatic system	G-392	MIL-G-4343
	Helicopter oscillating bearing	G-366	MIL-G-25537
	Extreme high temperature	G-372	MIL-G-25013
	Aircraft, multipurpose	G-395	MIL-G-81322 Grade A
	Aircraft, PTFE	G-396	MIL-G-83363
VIII.	<u>Hydraulic fluids</u>		
	Petroleum base	H-515	MIL-H-5606
	Fire resistant, synthetic	H-537	MIL-H-83282

FIGURE B-5. NATO code number cross reference - Continued.

MIL-STD-2161A(AS)

	<u>General type of product</u>	<u>NATO no. 1/</u>	<u>Applicable specification 2/</u>
IX.	<u>Miscellaneous oils</u>		
	Gear oil light (mineral type)	0-153	MIL-L-6086 Grade L
	Gear oil medium (mineral type)	0-155	MIL-L-6086 Grade M
	General purpose light oil	0-142	MIL-L-7870
	Synthetic oil instruments	0-147	MIL-L-6085
X.	<u>Specialty products</u>		
	Liquid, compass, aircraft	S-712	MIL-L-5020
	Deicing and defrosting fluid	S-742	MIL-A-8243 Type II
	Isopropanol	S-737	TT-I-735 Grade B
	Ethanol	S-738	O-E-760 Type III
	Petroleum	S-743	VV-P-236
	Molybdenum disulfide lubricant (dry)	S-740	MIL-M-7866
	Antiseize graphite-petroleum	S-720	MIL-T-5544
	Graphite	S-732	SS-G-659
	Electrical insulating and sealing compound	S-736	MIL-S-8660
	Lubricant, solid film airdrying	S-749	MIL-L-23398
	Molybdenum disulfide silicone base high temperature	S-1735	DOD-L-25681
	Antiseize compound, lead free	S-716	TT-S-1732

FIGURE B-5. NATO code number cross reference - Continued.

MIL-STD-2161A(AS)

	<u>General type of product</u>	<u>NATO no.</u> 1/	<u>Applicable specification</u> 2/
X.	<u>Specialty products</u> - Continued		
	Methanol, technical	S-747	O-M-232
	Fuel system deicing inhibitor	S-748	MIL-I-27686
	Antiseize tape, aircraft oxygen systems	S-1736	MIL-T-27730
	Lubricant, solid film, extreme environment	S-1737	MIL-L-81329
	Fuel system icing inhibitor	S-1745	MIL-I-85470
XI.	<u>Preservative compounds</u>		
	Aircraft engine corrosion preventive oil concentrate	C-608	MIL-C-6529 Type I
	Aircraft piston engine corrosion preventive oil	C-609	MIL-C-6529 Type II
	Aircraft turbine engine corrosion preventive oil	C-610	MIL-C-6529 Type III
	Heavy oil or wax thickened type	C-612	MIL-C-5545
	Corrosion preventive oil, gas turbine (synthetic base)	C-638	MIL-C-8188
	Hydraulic equipment corrosion preventive oil	C-635	MIL-H-6083
	Hard film cold application	C-632	MIL-C-16173 Grade 1
	Hard film hot application	C-633	MIL-C-11796 Grade 1
	Soft film cold application	C-620	MIL-C-16173 Grade 2
	Soft film hot application	C-627	MIL-C-11796 Grade 3

FIGURE B-5. NATO code number cross reference - Continued.

MIL-STD-2161A(AS)

<u>General type of product</u>	<u>NATO no.</u> <u>1/</u>	<u>Applicable specification</u> <u>2/</u>
XI. <u>Preservative compounds</u> - Continued		
Hydraulic fluid, rust inhibited, fire resistant, synthetic	H-544	MIL-H-46170

1/ NATO numbers are in accordance with STANAG 1135, Interchangeability Chart of NATO Standardized Fuels, Lubricants and Associated Products.

2/ Latest issues apply.

3/ There is no U.S. implementing military document for this lubricant.

FIGURE B-5. NATO code number cross reference - Continued.

MIL-STD-2161A(AS)

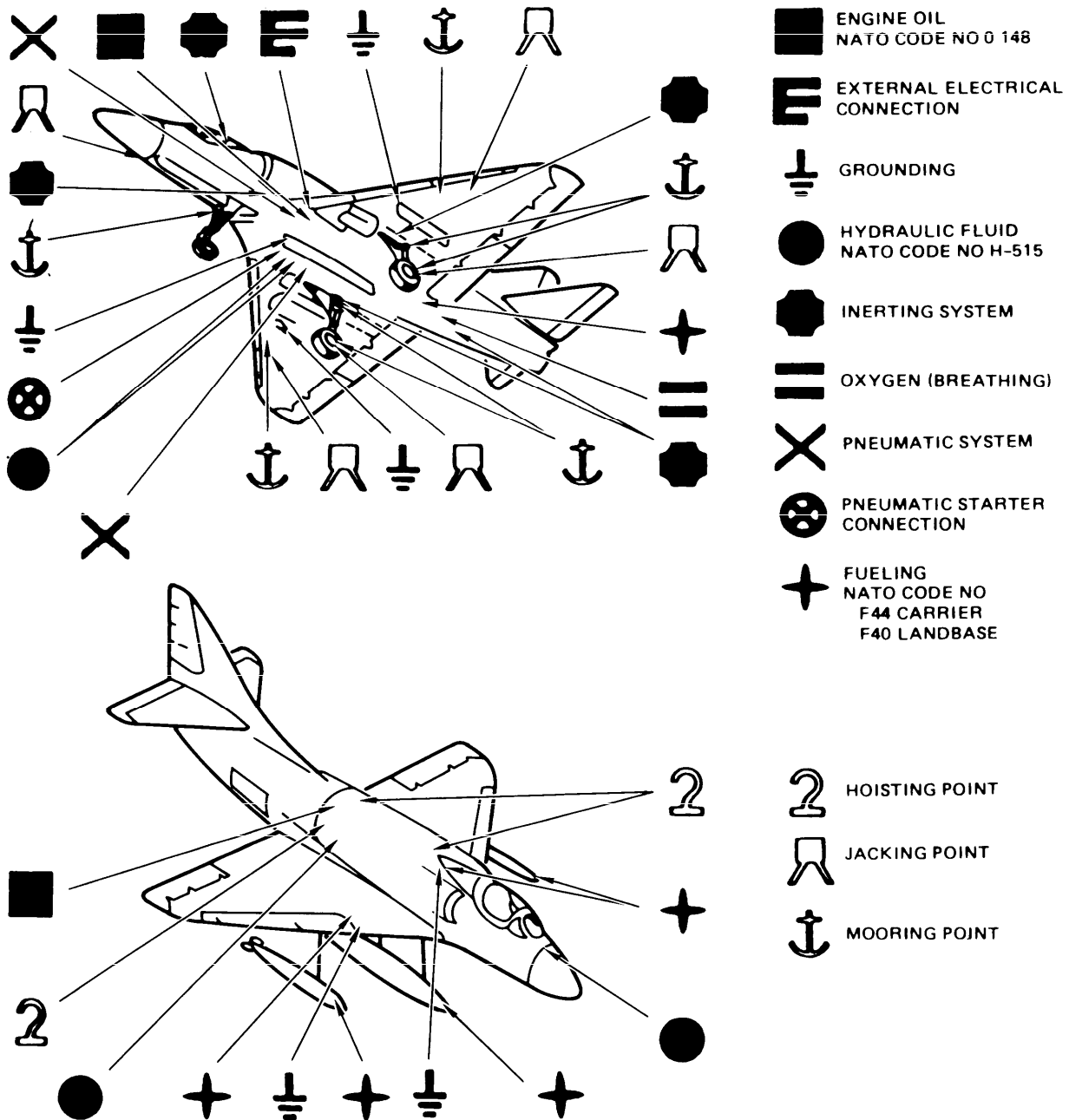


FIGURE B-6. Typical NATO aircraft servicing markings.

MIL-STD-2161A(AS)

SECTION I

MAINTENANCE

COLOR - AVIATION
YELLOW NO. 13538

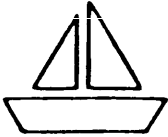
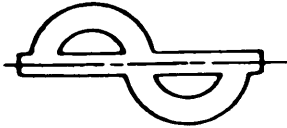
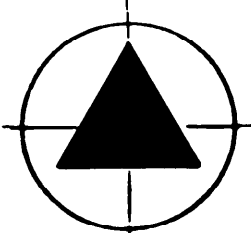
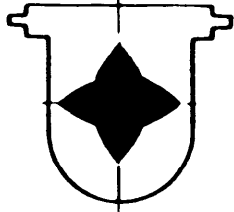
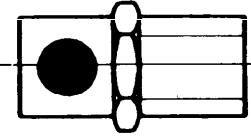
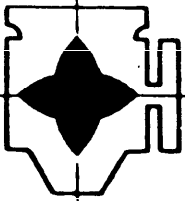
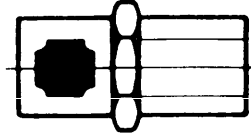
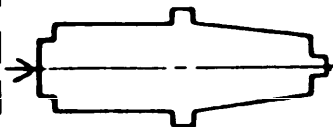
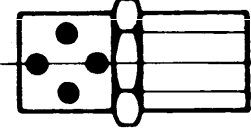
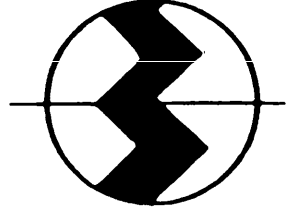
FUNCTION	SYMBOL	FUNCTION	SYMBOL
DINGHY STORAGE		INSPECTION OF ELECTRONIC INSTALLATION	
INSPECTION OF DE-ICING CIRCUIT		INSPECTION OF FUEL FILTER	
HYDRAULIC SYSTEM TEST POINT		FUEL TANK WATER DRAIN OFF	
INERTING FLUID TANK SYSTEM TEST POINT		IGNITION PLUG FOR STARTING JET ENGINE	
CABIN PRESSURE TEST POINT		INSPECTION OF STATIC CONNECTION (VENTS)	

FIGURE B-7. Required markings and symbols.

MIL-STD-2161A(AS)



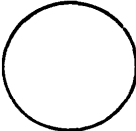

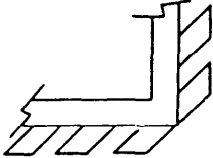

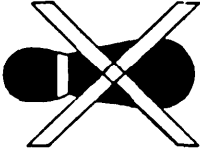


SECTION II			GROUND HANDLING		
FUNCTION	DESCRIPTION	SYMBOL	FUNCTION	DESCRIPTION	SYMBOL
NO GRIP	FILLED HAND WITH RED FILLED DIAGONAL CROSS SUPERIMPOSED		DRINKING WATER REPLENISHMENT	AVIATION YELLOW DISC SURROUNDING THE SYMBOL	
TAIL SUPPORT	AVIATION YELLOW CIRCLE AROUND THE POINT OF SUPPORT		TOILET SERVICING	AVIATION YELLOW DISC SURROUNDING THE SYMBOL	
WALKWAYS	SURROUNDED BY AN AVIATION YELLOW BORDER WITH RED FRINGE ON THE OUTSIDE		TELEPHONE CONNECTION GROUND TO COCKPIT	FILLED AVIATION YELLOW SYMBOL, AS SHOWN	
NO STEP	A FILLED FOOTPRINT WITH A RED DIAGONAL CROSS SUPERIMPOSED		FLIGHT DATA RECORDER	BLACK SYMBOLS ON WHITE BACKGROUND OR WHITE SYMBOLS ON BLACK BACKGROUND	
LOCKING OF DROP TANK	AVIATION YELLOW DISC CONTAINING FUEL SYMBOL IN RED				

FIGURE B-7. Required markings and symbols - Continued.

MIL-STD-2161A(AS)

SECTION III. HAZARD		COLOR - RED NO. 11136
FUNCTION	PART TO BE MARKED	SYMBOL
LOCKING OF CONTROLS AND UNDER CARRIAGE	UPRIGHTS AND CROSS-BARS	PAINTED RED AND WHITE AND FITTED WITH A RED PENNANT INCORPORATING REFLECTIVE STRIPES
AIRCRAFT POSITION OF LOCKS	POSITION OF UPRIGHTS AND CROSS-BARS	PAINTED RED
PITOT TUBE COVERING	COVER	PAINTED RED AND FITTED WITH A RED PENNANT INCORPORATING REFLECTIVE STRIPES
CAMERA GUN COVERING	CAMERA GUN CAP	
JET ENGINE COVERING	TAMPIONS	
ROCKET CONTROL	ELECTRIC PLUG	RED AND WHITE PENNANT
ANTIFIRING CONTROL	SHUNT	RED PENNANT WITH BLACK SKULL AND CROSS-BONES
PROHIBITION OF ACCESS	WEAKER PARTS OF AIRCRAFT	BORDER BAND AND CROSS OF ST. ANDREW IN RED

OPTIONAL MARKINGS


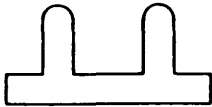

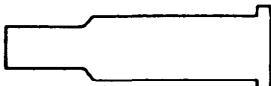
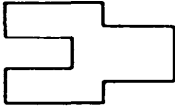
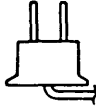

SECTION IV. ARMAMENT AND AMMUNITION		COLOR - GREEN NO. 14187
FUNCTION	PART TO BE MARKED	SYMBOL
GUN		
FIRING	SHUNT FOR CUTTING OUT FIRING SAFETY CONTROL	
FEEDING OF GUNS	CARTRIDGE	
CARTRIDGE CONTAINER	CARTRIDGE CASE	
LINKS CONTAINER	CONTAINER	
ROCKETS CONTROL	SELECTION PLUG	
BOMB HOIST	ATTACHMENT POINT FOR HOIST	

FIGURE B-7. Required markings and symbols - Continued.

MIL-STD-2161A(AS)

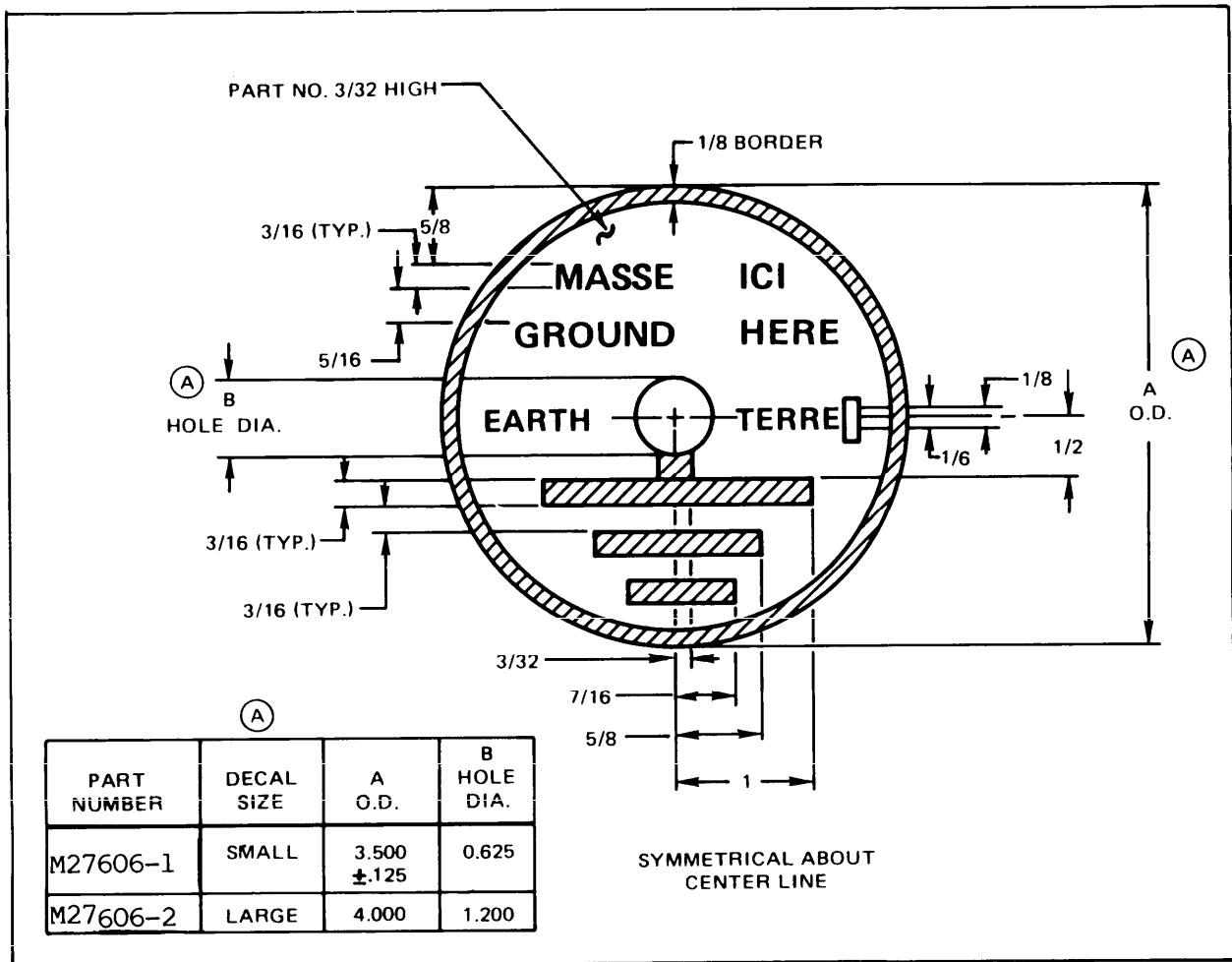


FIGURE B-8. Decalcomania - ground here, international symbol.

MIL-STD-2161A(AS)

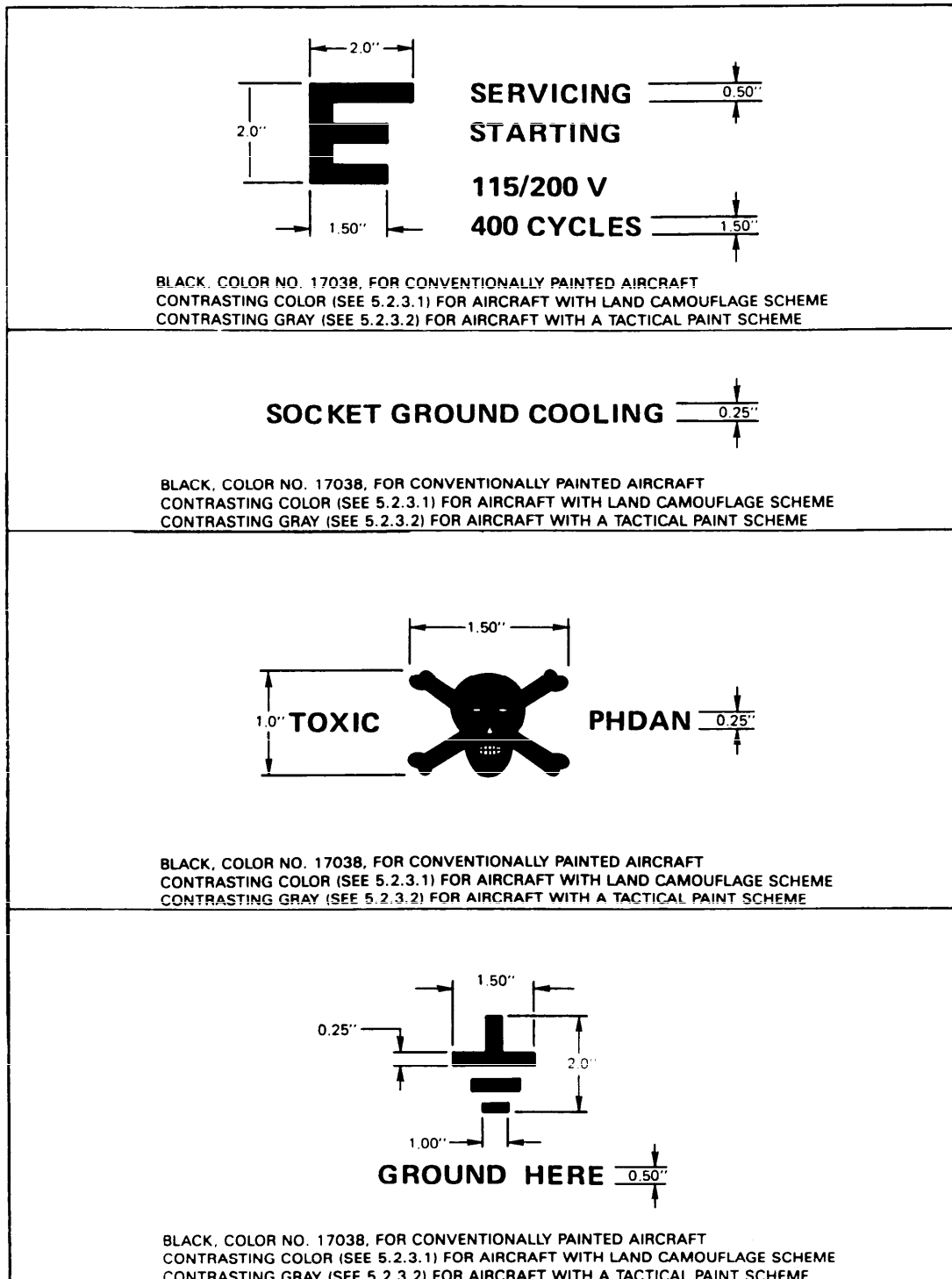


FIGURE B-9. Samples of ground servicing and hazard markings (size and color).

MIL-STD-2161A(AS)

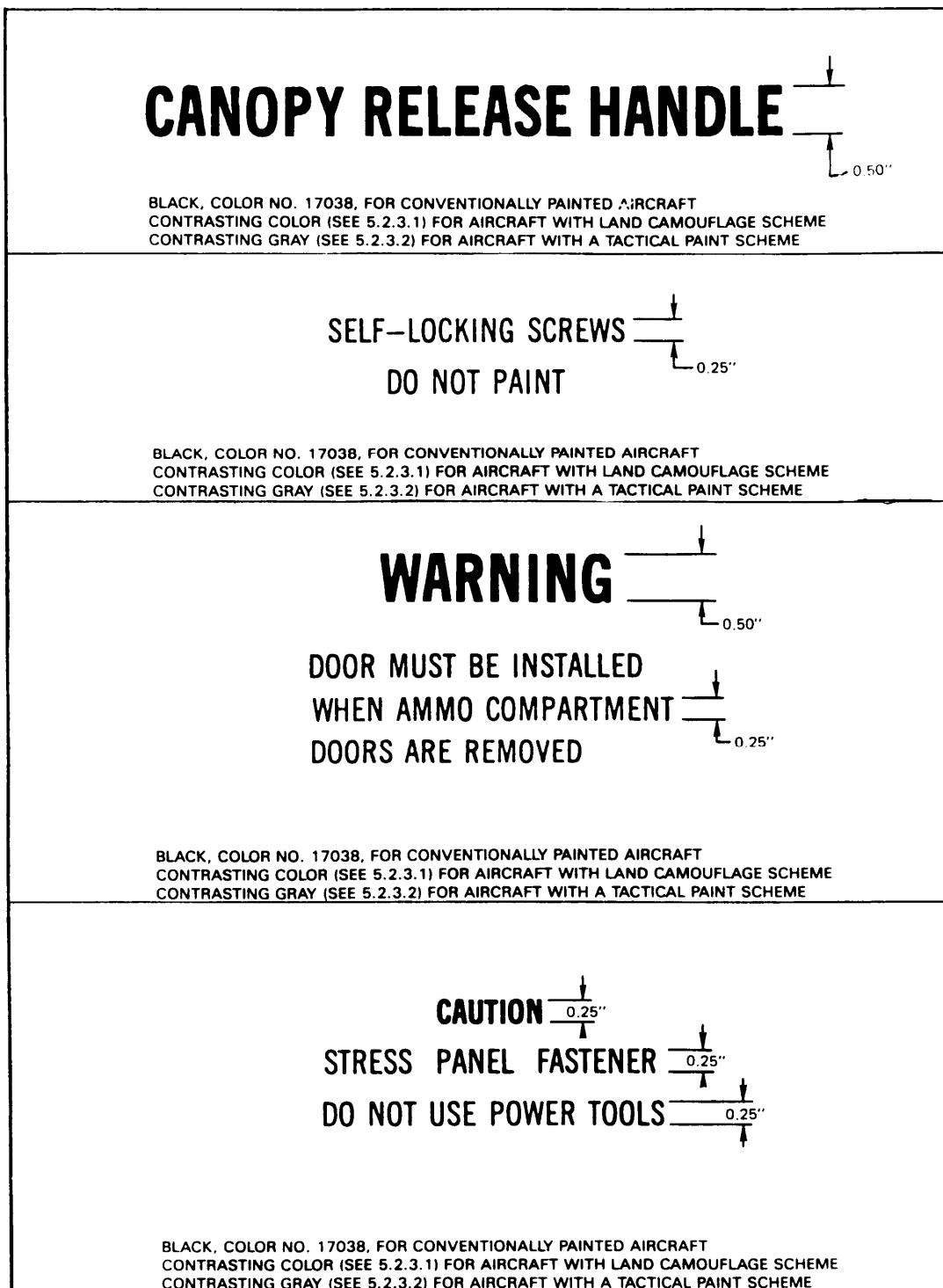


FIGURE B-9. Samples of ground servicing and hazard markings (size and color) - Continued.

MIL-STD-2161A(AS)

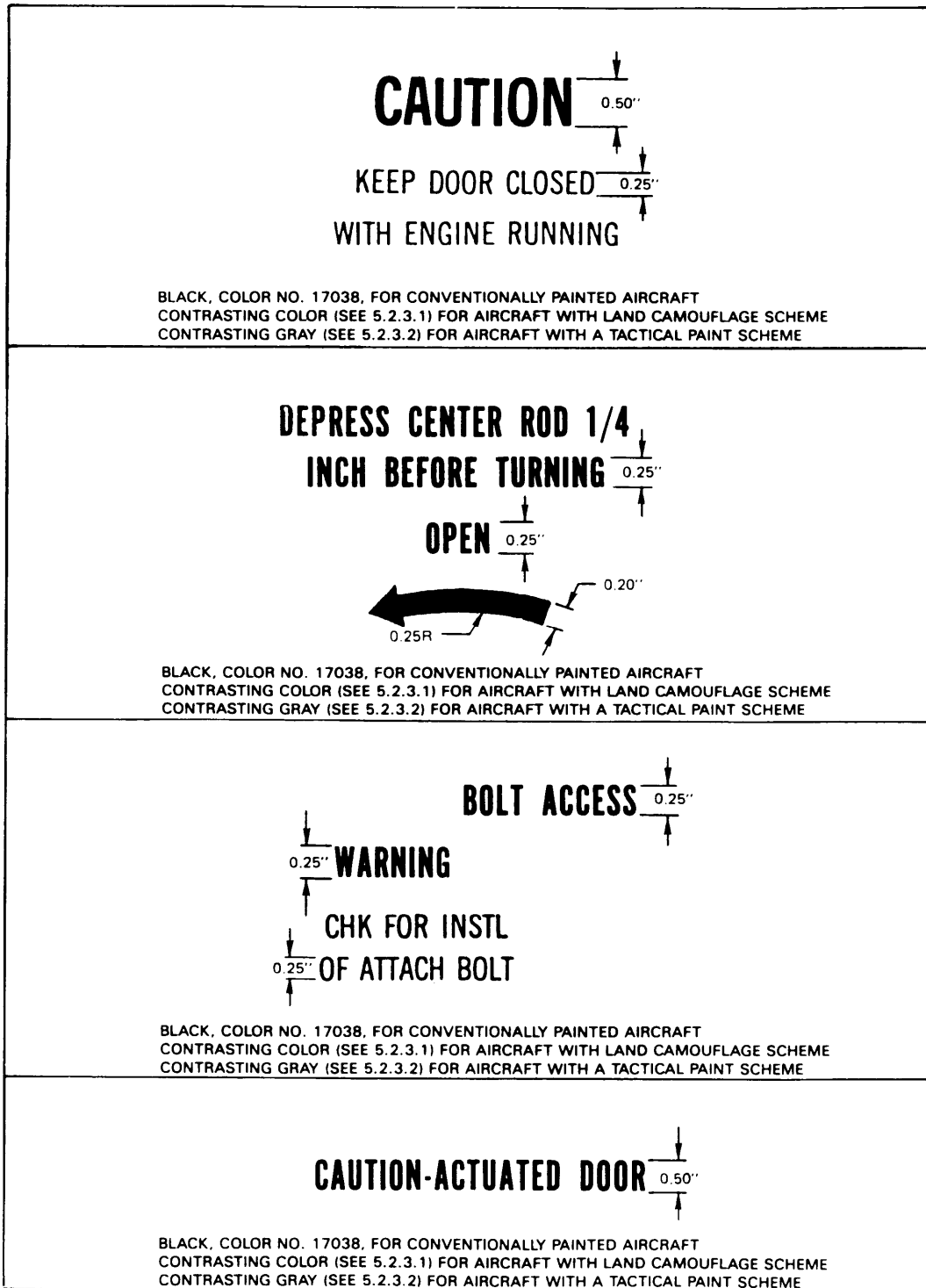


FIGURE B-9. Samples of ground servicing and hazard markings (size and color) - Continued.

MIL-STD-2161A(AS)

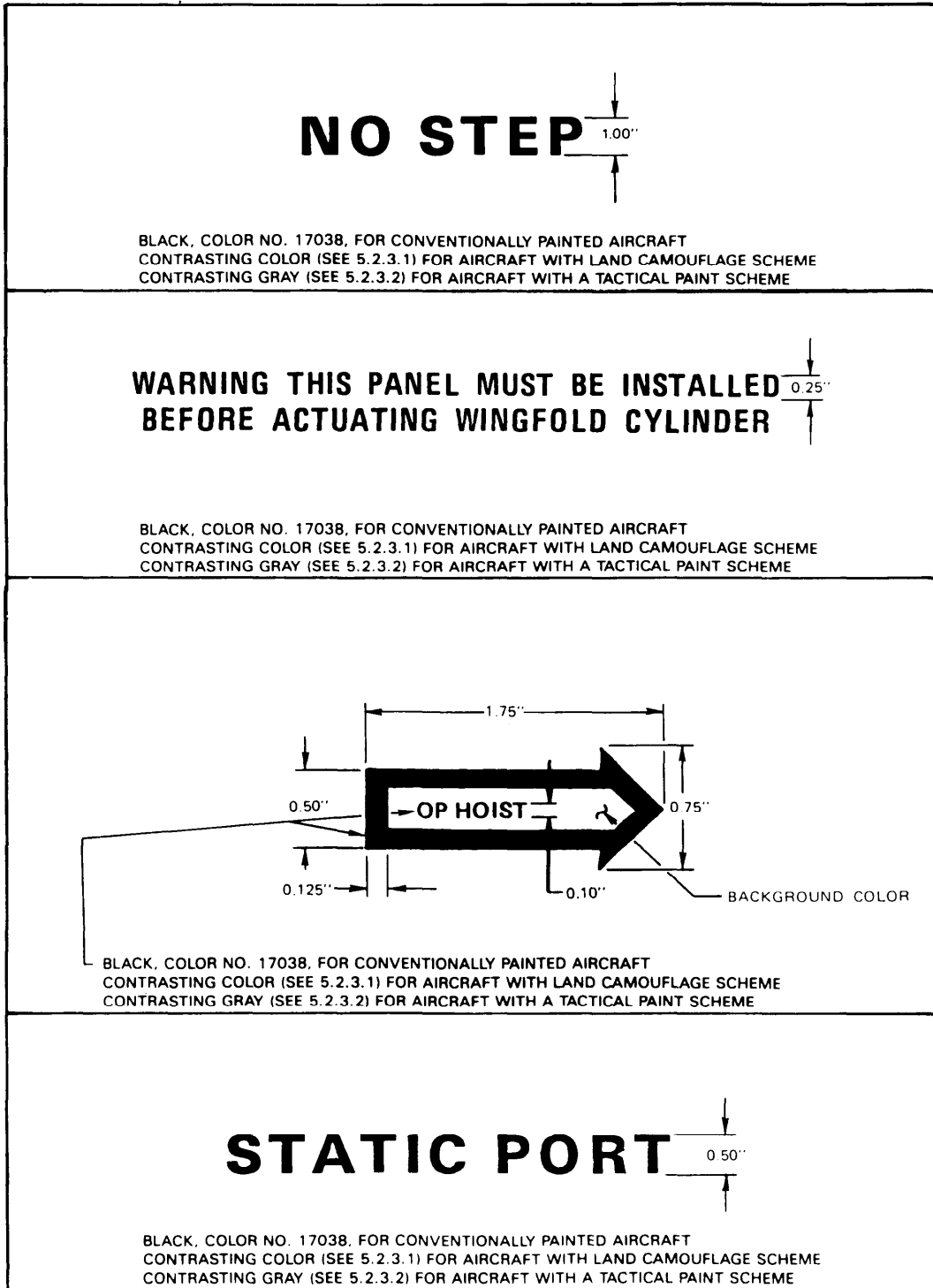


FIGURE B-9. Samples of ground servicing and hazard markings (size and color) - Continued.

MIL-STD-2161A(AS)

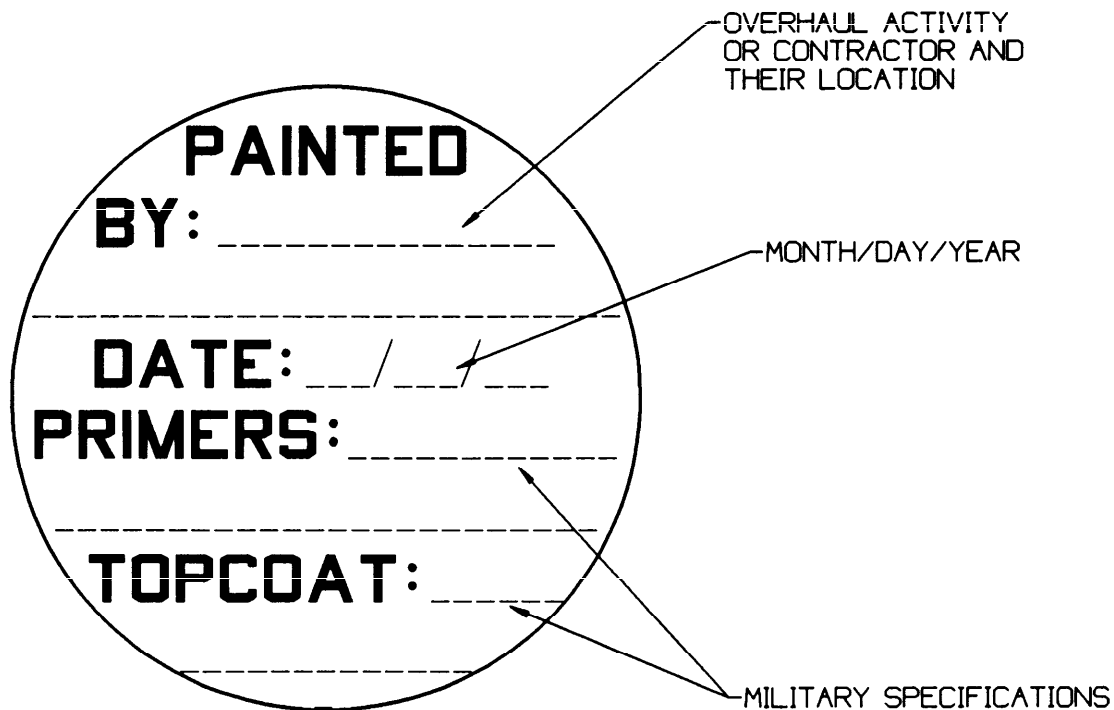


FIGURE B-10. Record of finish marking.

MIL-STD-2161A(AS)

APPENDIX C

FIGHTER, ATTACK, CARGO, UTILITY, TRAINER, AND SEARCH AND RESCUE (SAR) AIRCRAFT MARKING

10. SCOPE

10.1 Scope. This Appendix illustrated the different paint schemes for utility, cargo, SAR, fighter and attack aircraft.

10.2 Use. This Appendix is a mandatory part of this standard. The information contained herein is intended for compliance.

20. APPLICABLE DOCUMENTS. This section is not applicable to this Appendix.

30. DEFINITIONS

30.1 Definitions. For purposes of this Appendix, the definitions of this standard shall apply.

40. GENERAL REQUIREMENTS

40.1 Aircraft paint schemes. The following figures illustrate aircraft finish and marking specifications for utility, cargo, SAR, fighter and attack aircraft.

MIL-STD-2161A(AS)

1. MARKING	2. LOCATION	3. SIZE	4. COLOR NO/CODE
A. NAVY	Aft Fuselage	16"	17038
B. Model Designation, Acft BUNO	Aft Fuselage	1½" (2) 3¾" (4)	17038
C. National Star	Aft Fuselage Upper L. H. Wing Lower R. H. Wing	40" 40" 40"	17925 15044 11136
D. Call Numbers	Vertical Stabilizer	16"	17038
E. Intake Warning	Fwd. Engine Nacelle	21.5"	11136/17925
F. Beware of Blast	Aft Fuselage	7"	11136
G. Arresting Hook Marking	Aft Fuselage	2.12"	11136/17925
H. Walkway	Aft of Cockpit, Top Center of Fuselage and Wing Root	N/A	37038
I. Unit Identifier	Upper R. H. Wing Vertical Stabilizer Lower R. H. Wing	30" 30" 16"	17038
J. Antiglare	Forward of Cockpit	N/A	37038
K. Unit Aircraft Numbers	Upper R. H. Wing Forward Fuselage Lower L. H. Wing	24" 30" 16"	17038
L. Rescue Arrow	R.H. & L.H. Side of Fuselage, Near Canopy Rail	24"	13538/17038

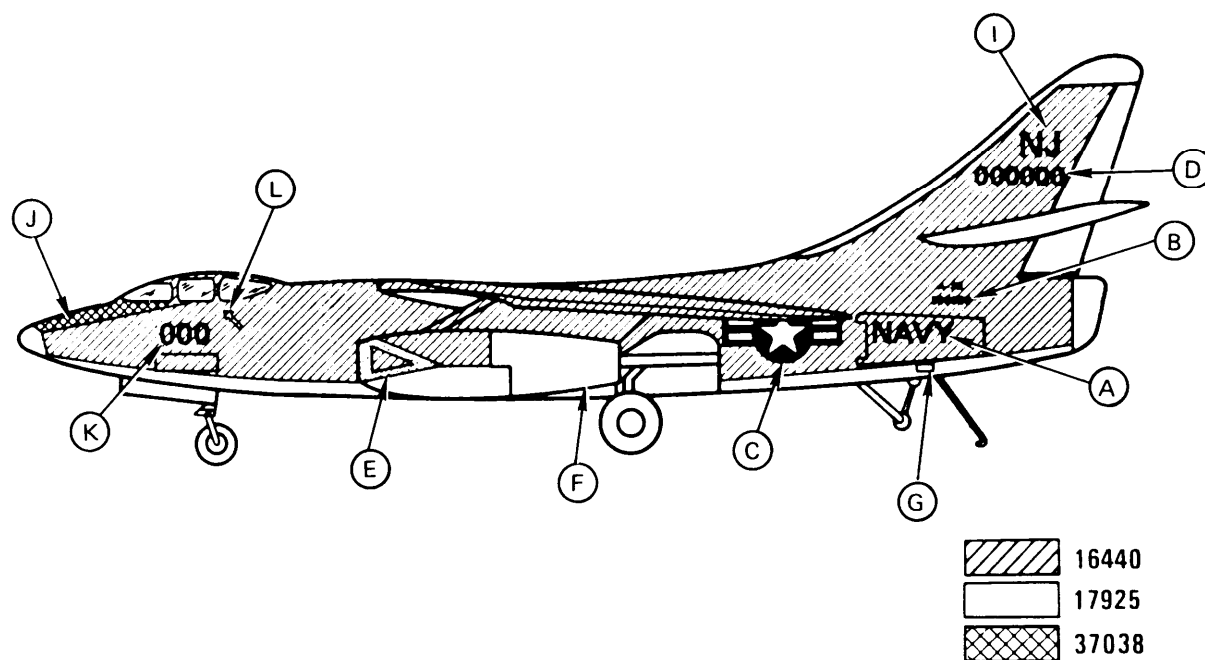


FIGURE C-1. A-3B aircraft marking.

MIL-STD-2161A(AS)

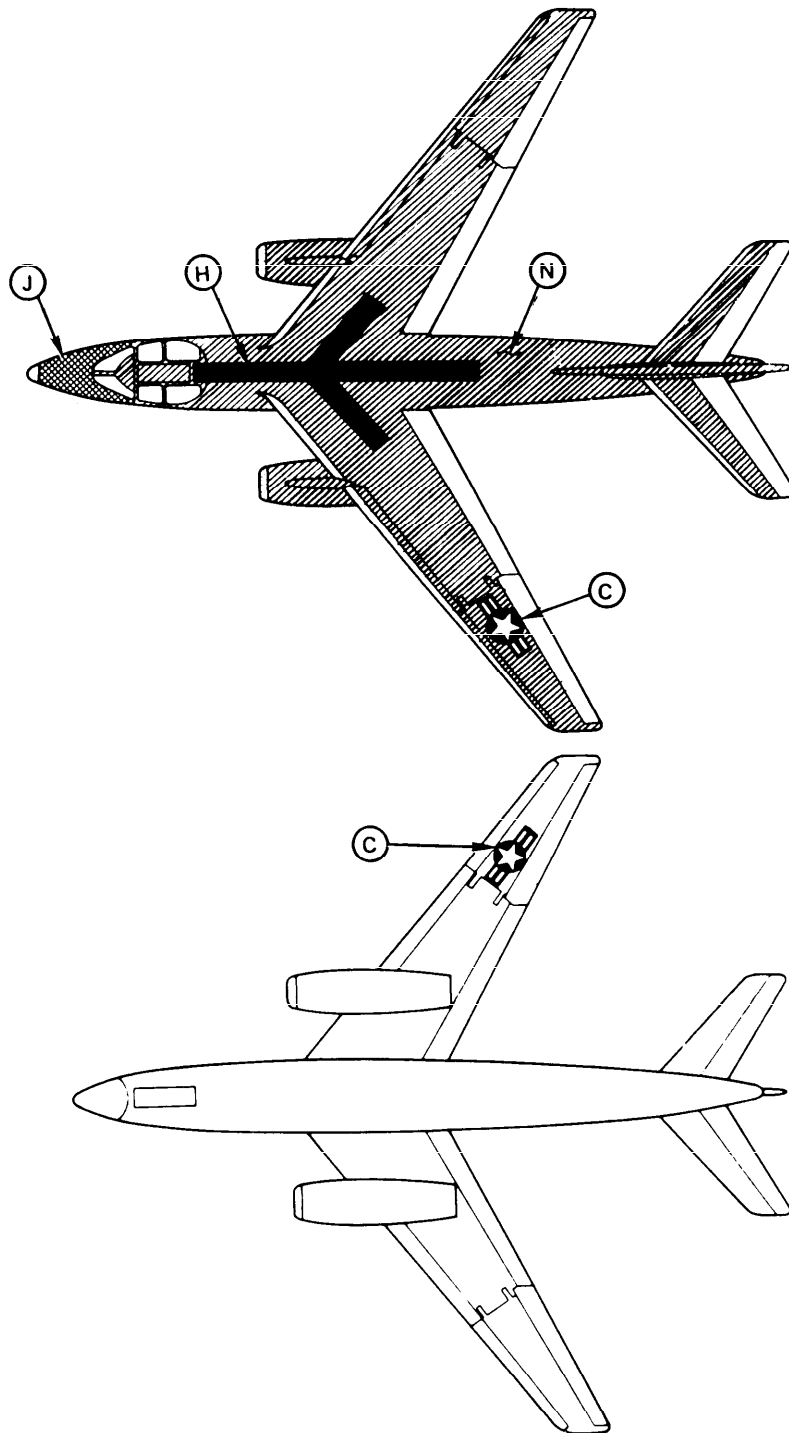
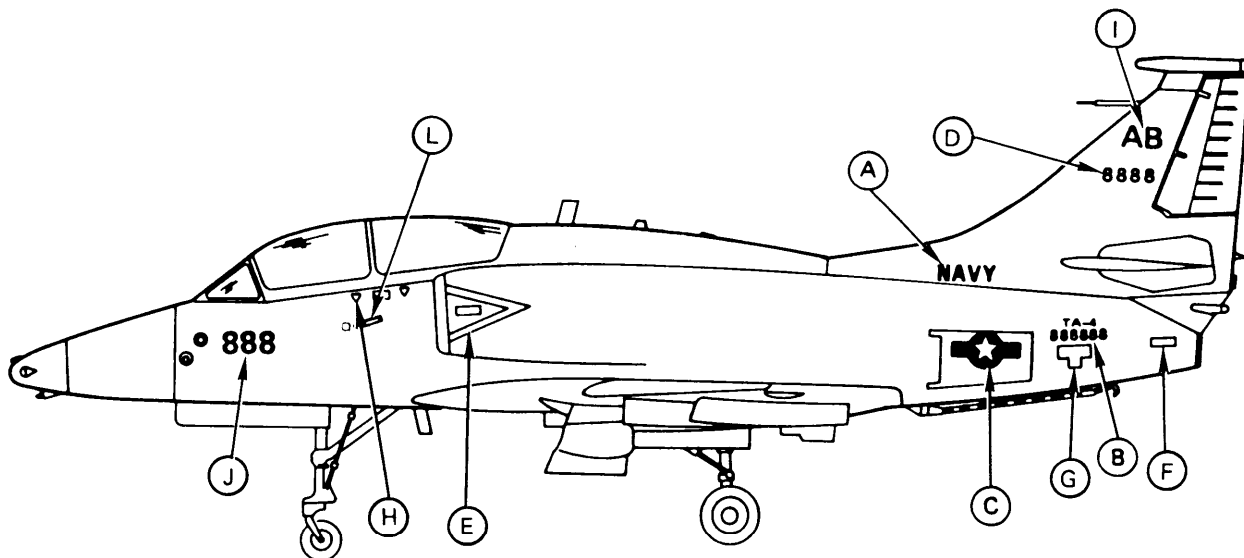


FIGURE C-1. A-3B aircraft marking - Continued.

MIL-STD-2161A(AS)

1. MARKING	2. LOCATION	3. SIZE	4. COLOR NO/CODE
A. NAVY/MARINES	Lower Vertical Stabilizer	12"/10"	IAW Para. 5.2.3 & Figure A-15
B. Model Designation, Acft BUNO	Aft Fuselage - Side	2" 4"	IAW Para. 5.2.3 & Figure A-15
C. National Star	Aft Fuselage Upper L.H. Wing Lower R.H. Wing	12" 12" 12"	IAW Para. 5.2.3 & Figure A-14
D. Call Numbers	Vertical Stabilizer	10"	IAW Para. 5.2.3
E. Intake Warning	Jet Engine Nacelles	See Para. 5.2.2.10.1	IAW Para. 5.2.3 & Figure A-15
F. Beware of Blast	Side of Engine Exhaust	7"	IAW Para. 5.2.3
G. Arresting Hook Marking	Aft Fuselage	14"	IAW Para. 5.2.3 & Figure A-14
H. Ejection Seat Warning	See Figure A-11	8"	IAW Para. 5.2.3 & Figure A-16
I. Unit Identifier	Vertical Stabilizer	12"	IAW Para. 5.2.3
J. Unit Aircraft Numbers	Fwd. Fuselage	12"	IAW Para. 5.2.3
K. Walkway	Wings Next to Fuselage	N/A	IAW Para. 5.1.13
L. Rescue Arrow	R.H. & L.H. Side of Canopy	24"	IAW Para. 5.2.3 & Figure A-14

FIGURE C-2. A/TA-4 aircraft marking (tactical).

MIL-STD-2161A(AS)

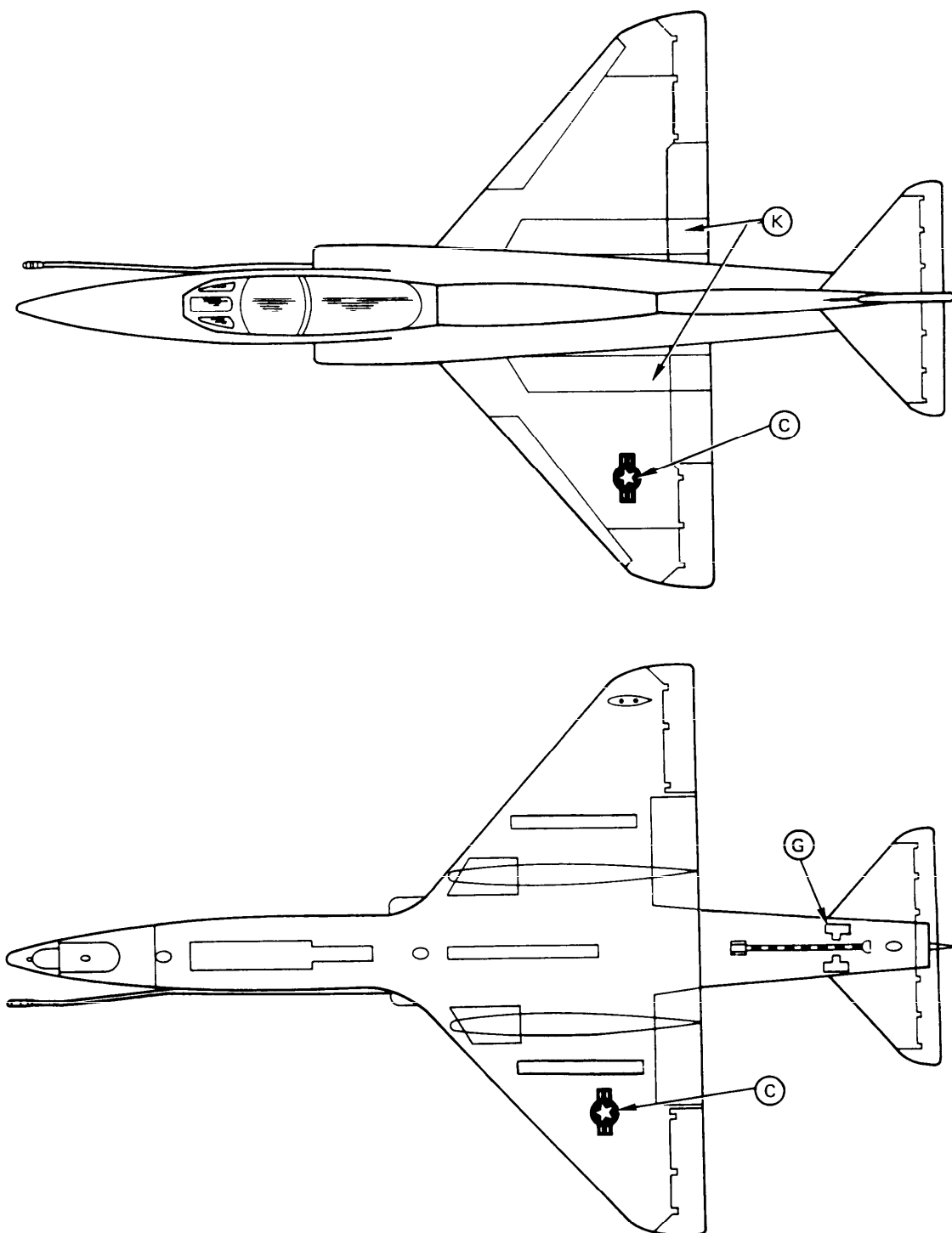


FIGURE C-2. A/TA-4 aircraft marking (tactical) - Continued.

MIL-STD-2161A(AS)

1. MARKING	2. LOCATION	3. SIZE	4. COLOR NO/CODE
A. NAVY/MARINES	Lower Vertical Stabilizer	12"	17038
B. Model Designation, Acft BUNO	Aft Fuselage	2" 4"	17038
C. National Star	Aft Fuselage Upper L.H. Wing Lower R.H. Wing	30" 30" 30"	15044/11136/ 17925
D. Call Numbers	Vertical Stabilizer	12"	17038
E. Intake Warning	Jet Engine Nacelles	See Para. 5.2.2.10.11	11136/17925
F. Beware of Blast	Side of Engine Exhaust	7"	IAW Para. 5.2.2.10.2
G. Arresting Hook Marking	See Figure A-14	4"	17925/17038
H. Ejection Seat Warning	Under Canopy Rail See Figure A-11	8"	11136/17038
I. Conspicuity Markings	See Para. 5.1.1.1	N/A	12197
J. Unit Identifier	Vertical Stabilizer Lower R.H. Wing Upper R.H. Wing	16" 20"	17038
K. Unit Aircraft Numbers	Fwd. Fuselage Upper R.H. Wing Lower L.H. Wing	12" 16" 16"	17038
L. Walkway	Wings Next to Fuselage	N/A	17038
M. Rescue Arrow	R.H. & L.H. Side of Canopy	24"	17038/13538
N. Antiglare	Forward of Cockpit	N/A	37038

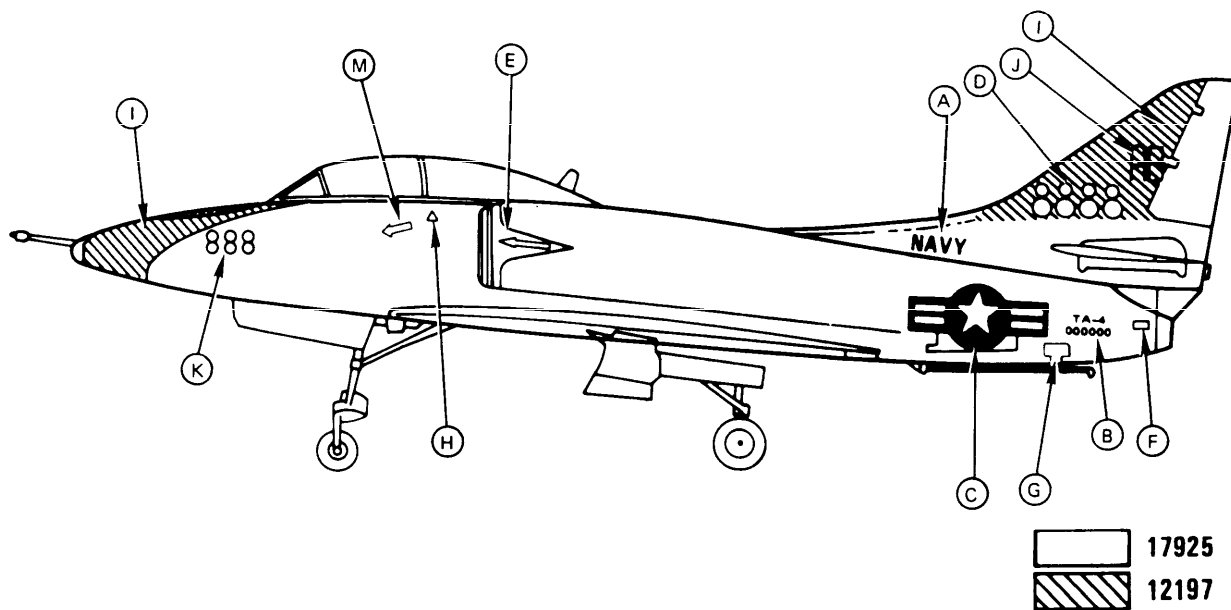


FIGURE C-3. A/TA-4 aircraft marking (high visibility).

MIL-STD-2161A(AS)

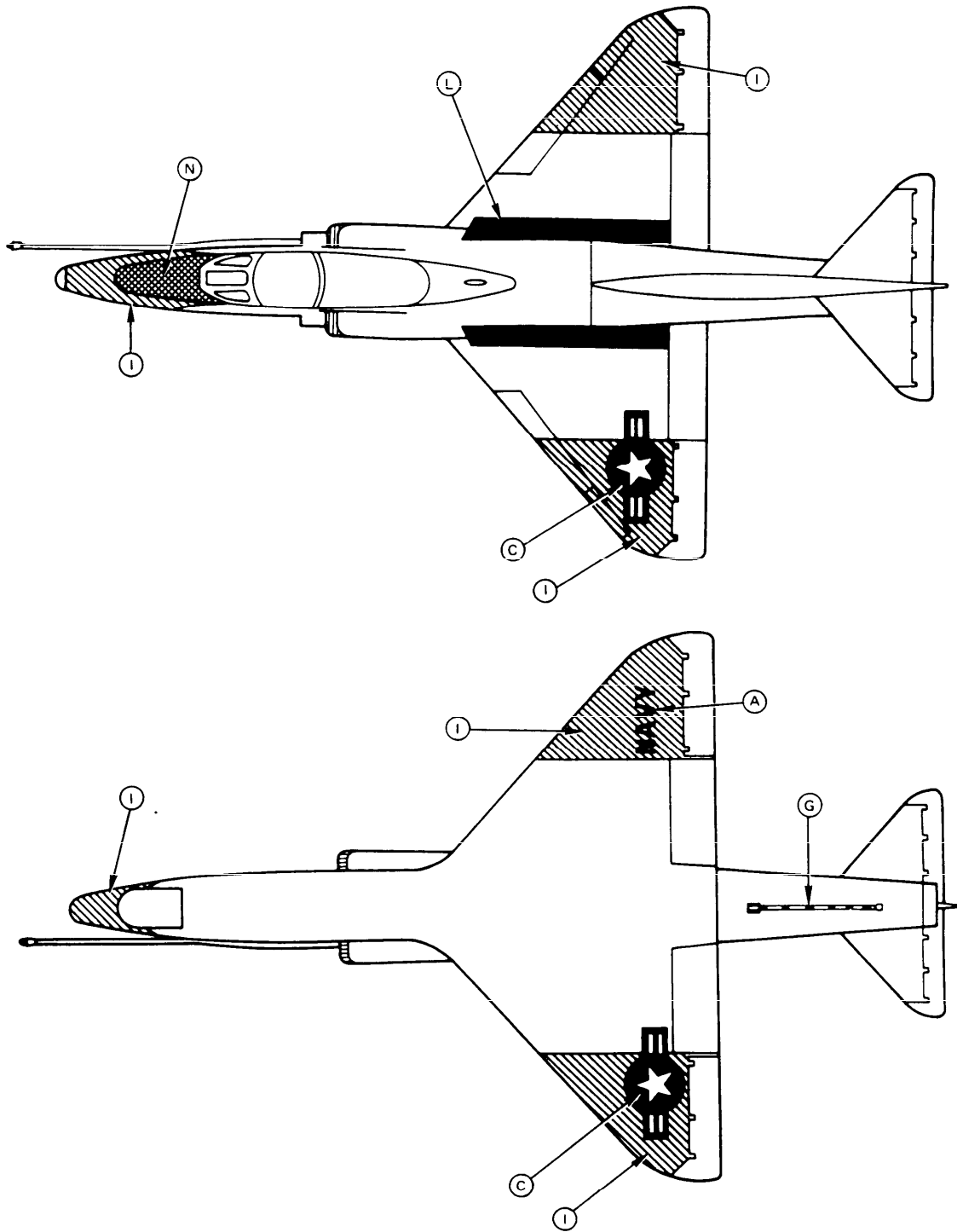
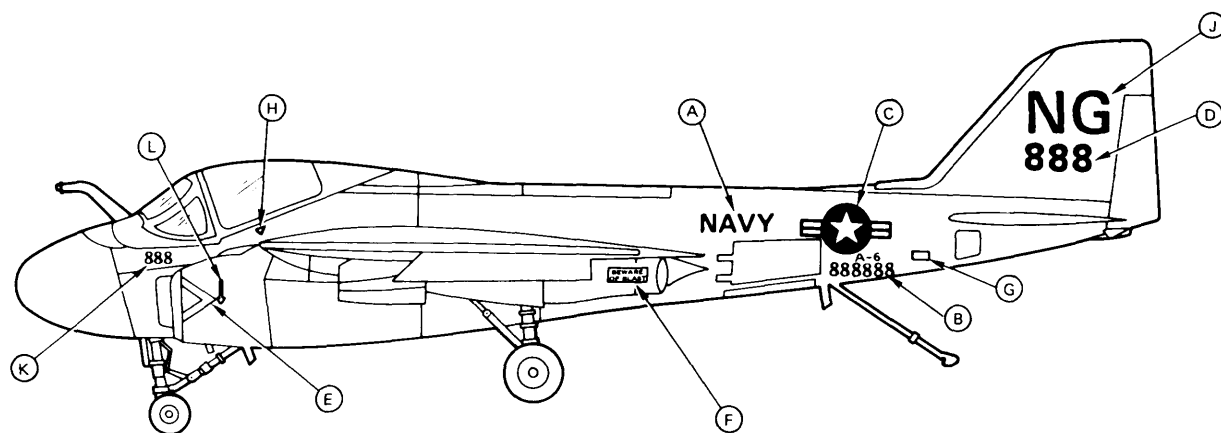


FIGURE C-3. A/TA-4 aircraft marking (high visibility) - Continued.

MIL-STD-2161A(AS)

1. MARKING	2. LOCATION	3. SIZE	4. COLOR NO/CODE
A. NAVY/MARINES	Aft Fuselage	12"	IAW Figure A-15, 35237
B. Model Designation, Acraft BUNO	Below National Star Below National Star	2" 4"	IAW Figure A-15, 35237
C. National Star	Aft Fuselage Upper L. H. Wing Lower R. H. Wing	12" 12" 12"	IAW Figure A-1, 35237
D. Call Numbers	Lower Vertical Stabilizer	12"	35237
E. Intake Warning	Engine Intake Nacelles	See Para. 5.2.2.10.1	IAW Figure A-15, 35237
F. Beware of Blast	Aft Engine Exhaust Outlet	15"	IAW 5.2.3
G. Arresting Hook Marking	Aft Fuselage	13"	IAW Figure A-14, 35237
H. Ejection Seat Warning	Below Canopy Rail	8"	IAW Figure A-16, 35237
I. Walkway	Upper Fuselage Wings Next to Fuselage	N/A	IAW Para. 5.1.13
J. Unit Identifier	Vertical Stabilizer Upper R. H. Wing	30" 30"	35237
K. Unit Aircraft Numbers	Forward Fuselage Upper R. H. Wing	12" 24"	IAW Para. 5.2.3
L. Rescue Arrow	R.H. & L.H. Sides of Canopy	24"	IAW Figure A-14, 35237

FIGURE C-4. A-6 aircraft marking (tactical).

MIL-STD-2161A(AS)

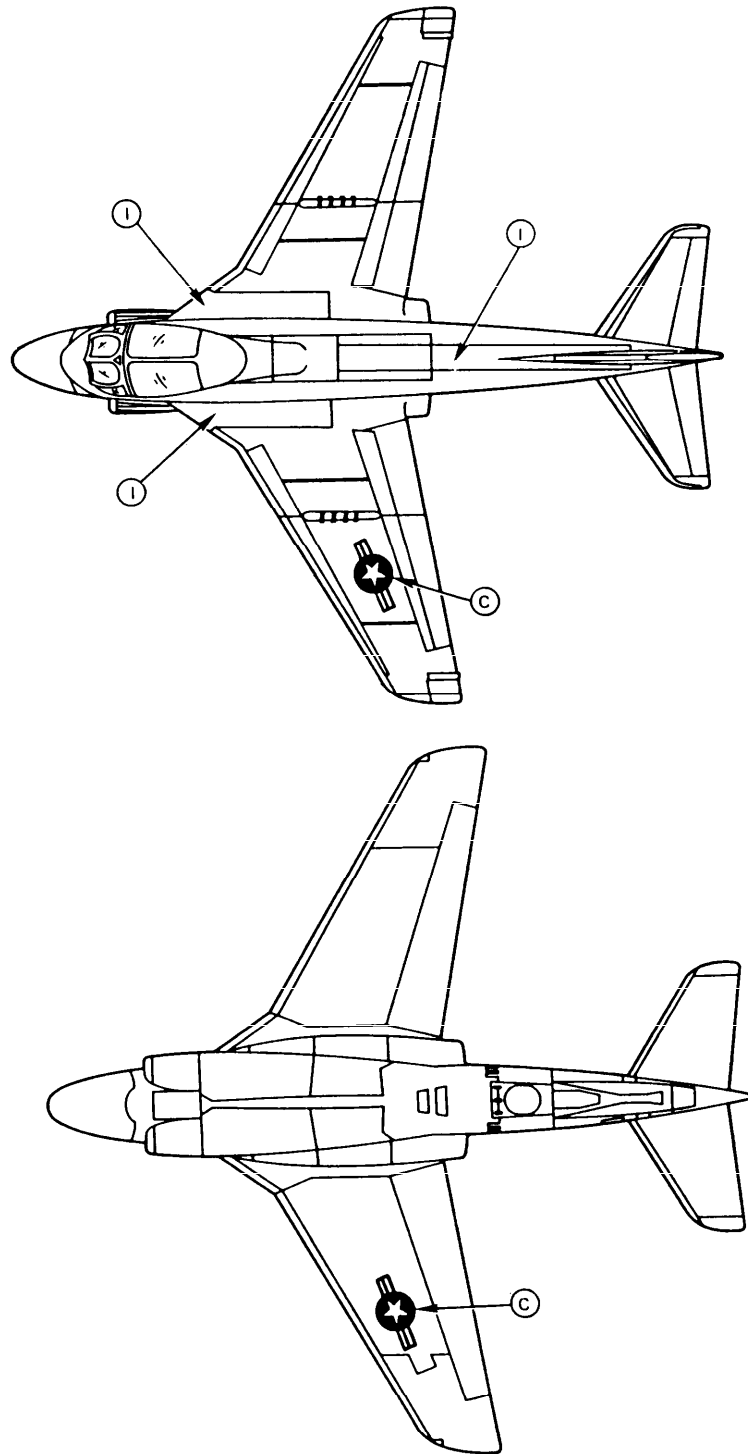
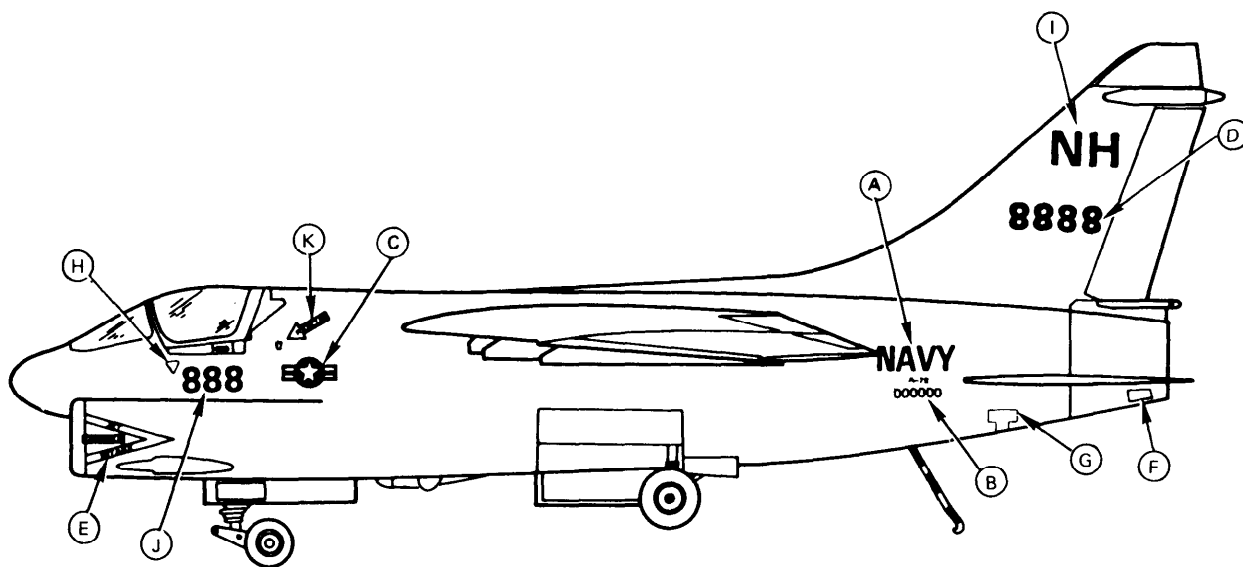


FIGURE C-4. A-6 aircraft marking (tactical) - Continued.

MIL-STD-2161A(AS)

1. MARKING	2. LOCATION	3. SIZE	4. COLOR NO/CODE
A. NAVY	Aft Fuselage	12"	IAW Figure A-15, 35237
B. Model Designation, Acft BUNO	Aft Fuselage	2" 4"	IAW Figure A-15, 35237
C. National Star	Fwd. Fuselage Lower R. H. Wing Upper L. H. Wing	12" 12" 12"	IAW Figure A-1, 35237
D. Call Numbers	Vertical Stabilizer	10"	35237
E. Intake Warning	Fwd. Fuselage	21.5"	IAW Figure A-15, 35237
F. Beware of Blast	Aft Fuselage	7"	35237
G. Arresting Hook Marking	Aft Fuselage	14"	IAW Figure A-14, 35237
H. Ejection Seat Warning	Below Canopy Rail	8"	IAW Figure A-16, 35237
I. Unit Identifier	Upper Vertical Stabilizer		35237
J. Unit Aircraft Numbers	Fwd. Fuselage		IAW Para. 5.2.3
K. Rescue Arrow	R.H. & L.H. Sides of Canopy	24"	IAW Figure A-14, 35237
L. Walkway	Horizontal Stabilizer Next to Fuselage	N/A	IAW Para. 5.1.13

FIGURE C-5. A-7 aircraft marking (tactical).

MIL-STD-2161A(AS)

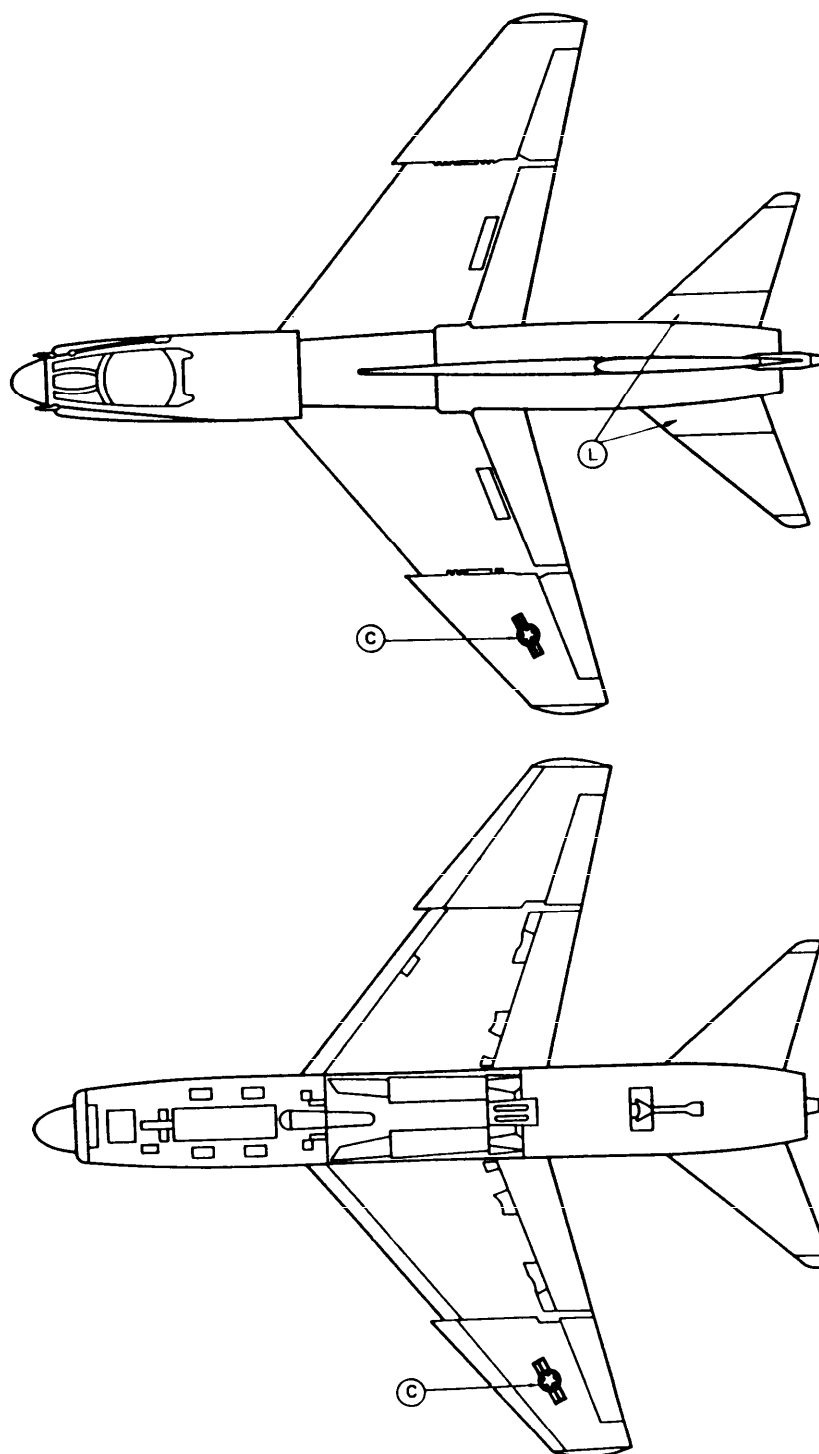


FIGURE C-5. A-7 aircraft marking (tactical) - Continued.

MIL-STD-2161A(AS)

1. MARKING	2. LOCATION	3. SIZE	4. COLOR NO/CODE
A. MARINES	Lower Vertical Stabilizer Upper R.H. Wing	7" 12"	37038
B. Model Designation, Acraft BUNO	Lower Aft Fuselage	2" 4"	37038
C. National Star	Fwd. Fuselage Upper L.H. Wing Lower R.H. Wing	20" 25" 25"	37038
D. Call Numbers	Vertical Stabilizer	7"	37038
E. Intake Warning	Engine Intake Nacelles	See Para. 5.2.2.10.1	37038
F. Beware of Blast	Engine Exhaust Nacelles	See Figure A-8	37038
G. Ejection Seat Warning	Below Canopy Rail	8"	37038/11136
H. Unit Identifier	Upper Aft Fuselage	4"	37038
I. Unit Aircraft Numbers	Fwd. Fuselage	12"	37038
J. Rescue Arrow	R.H. & L.H. Side of Canopy	24"	37038/34095

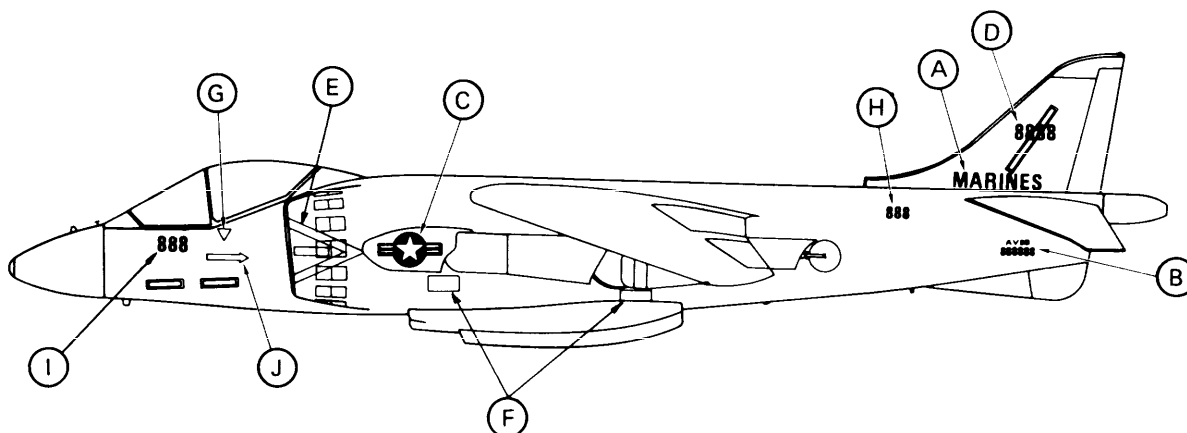


FIGURE C-6. AV-8B aircraft marking (land camouflage).

MIL-STD-2161A(AS)

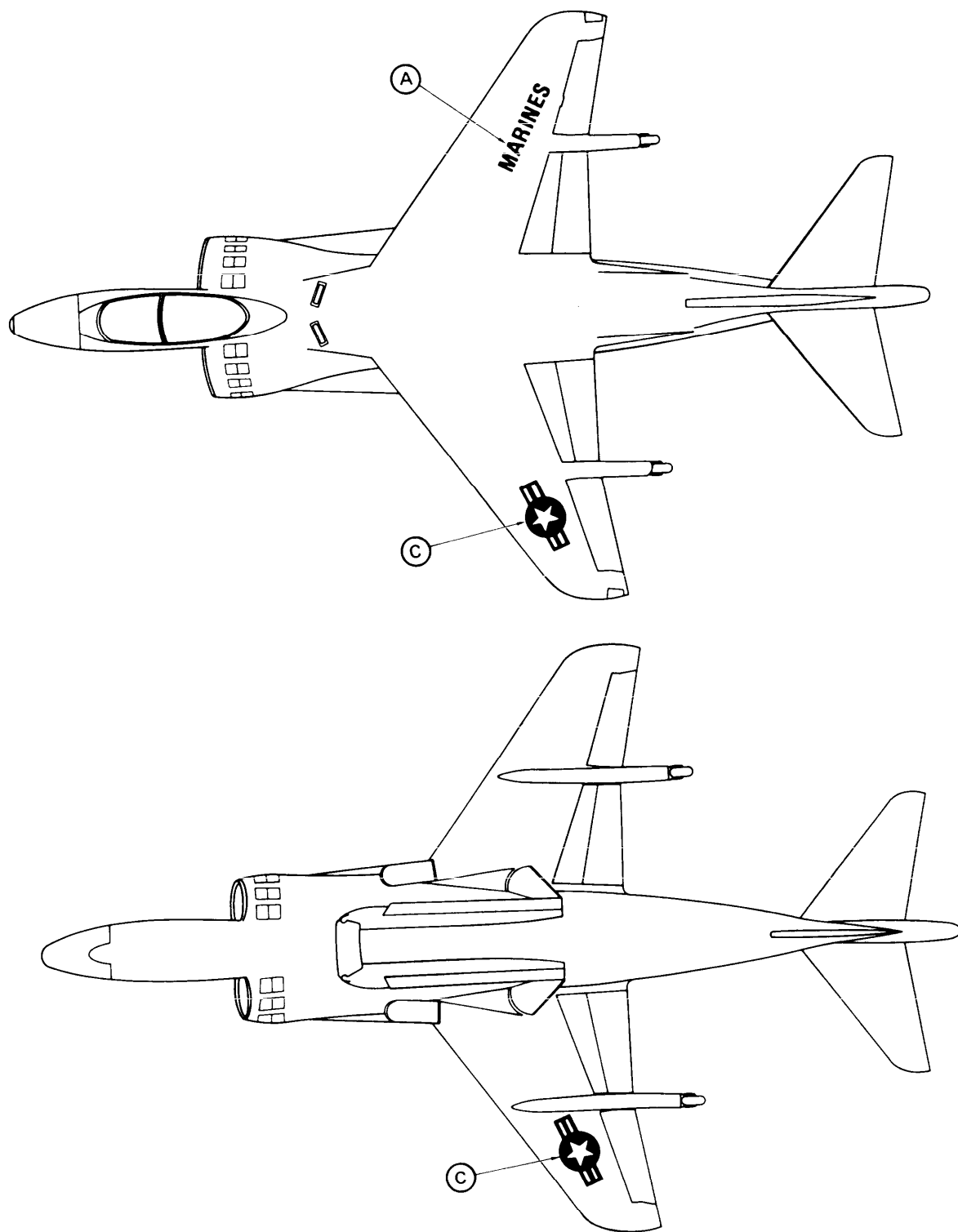


FIGURE C-6. AV-8B aircraft marking (land camouflage) - Continued.

MIL-STD-2161A(AS)

1. MARKING	2. LOCATION	3. SIZE	4. COLOR NO/CODE
A. NAVY	Aft Fuselage	16"	17038
B. Model Designation, Acft BUNO	Lower Aft Fuselage	2" 4"	17038
C. National Star	Aft Fuselage Upper L.H. Wing Lower R.H. Wing	40" 30" 30"	11136 15044 17925
D. Call Numbers	Vertical Stabilizer	12"	17038
E. Antiglare	Upper ½ Nose and Inside Upper ½ Eng Cowl	N/A	37038
F. Walkway	Center Top of Fuselage, Wing Root & Engine Cowlings	N/A	37038
G. Propeller Warning Band	Fwd. Fuselage (See Figure A-9)	3"	11136/17925
H. Flag	Vertical Stabilizer	26 X 46	11136/15044/17925
I. Unit Aircraft Numbers	Nose	16"	17038
J. Unit Identifier	Vertical Stabilizer	30"	37038
K. Propeller Tips	See Figure A-6	N/A	See Figure A-6
L. Arresting Hook Marking	Aft Fuselage	7"	17038
M. Rescue Arrow	Top Fwd. Fuselage, Aft of Cockpit	18"	17038

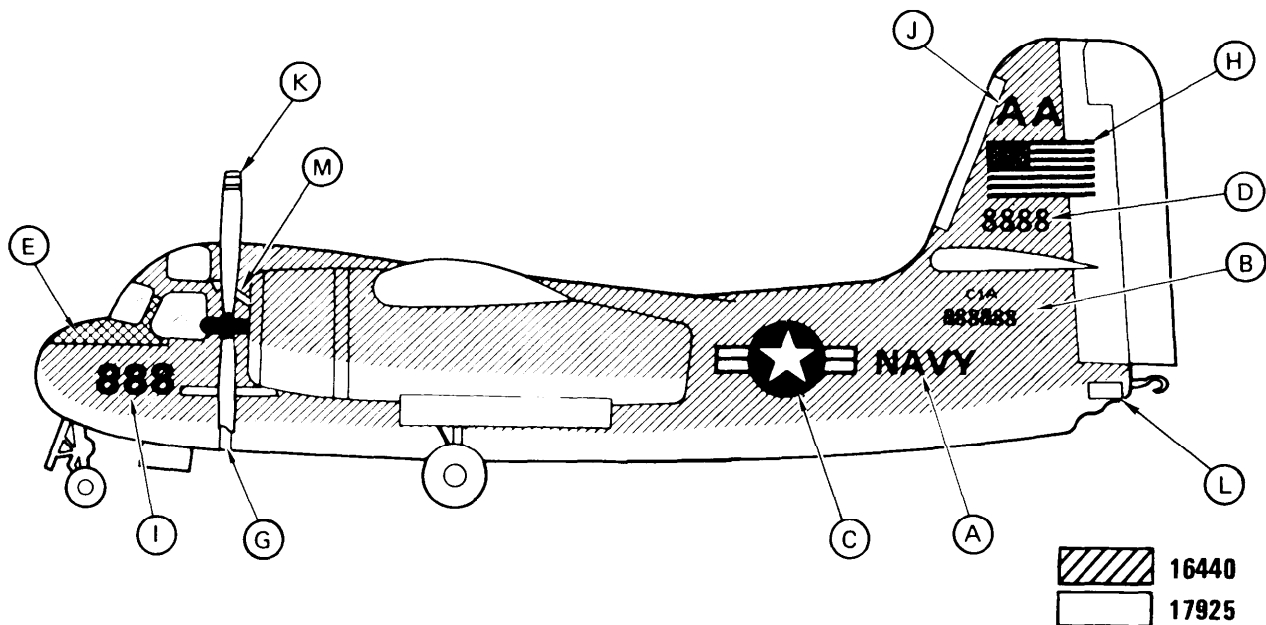


FIGURE C-7. C-1A aircraft marking.

MIL-STD-2161A(AS)

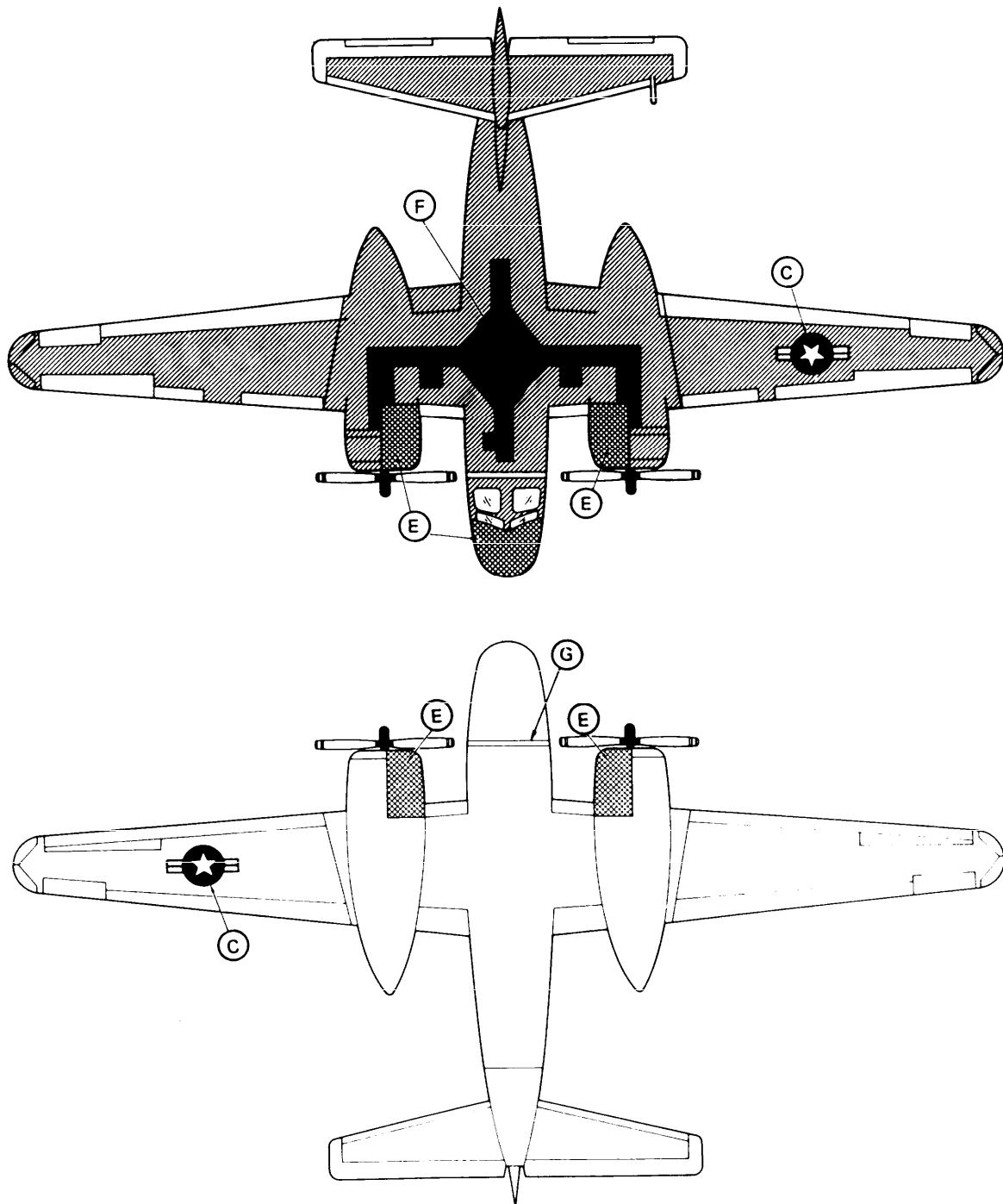


FIGURE C-7. C-1A aircraft marking - Continued.

MIL-STD-2161A(AS)

1. MARKING	2. LOCATION	3. SIZE	4. COLOR NO/CODE
A. UNITED STATES NAVY	Center Fuselage	12"	17038
B. Model Designation, Acft BUNO	Aft Fuselage	2" 4"	17038
C. National Star	Aft Fuselage Upper L. H. Wing Lower R. H. Wing	40" 40" 40"	11136 15044 17925
D. Call Numbers	Mid Vertical Stabilizer (Outsides Only)	12"	17038
E. Propeller Tips	N/A	3"/6"/3"	17925/11136/17925 See Figure A-6
F. Antiglare	Nose & Propeller Hubs	N/A	37038
G. Arresting Hook Marking	Aft Fuselage Doors	13"	17038
H. Walkway	Per Drawing	Per Drawing	37038
I. Propeller Warning Band	Fwd. Fuselage	3" (See Figure A-9)	11136
J. Rescue Arrow	Fwd. Fuselage Toward Pilot Compartment Door	24"	17038

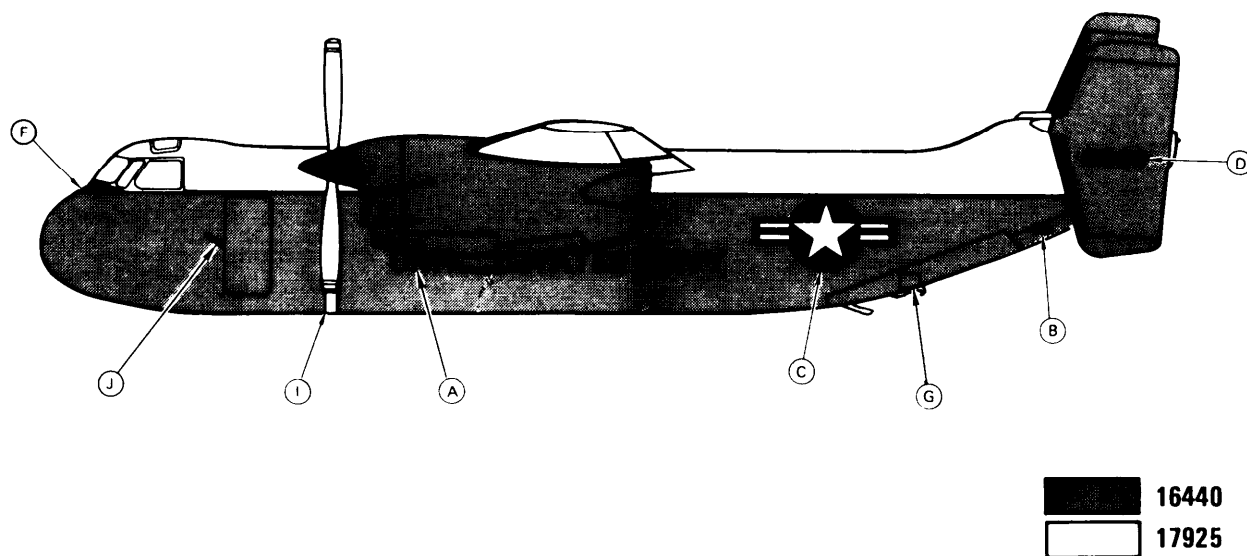


FIGURE C-8. C-2A aircraft marking.

MIL-STD-2161A(AS)

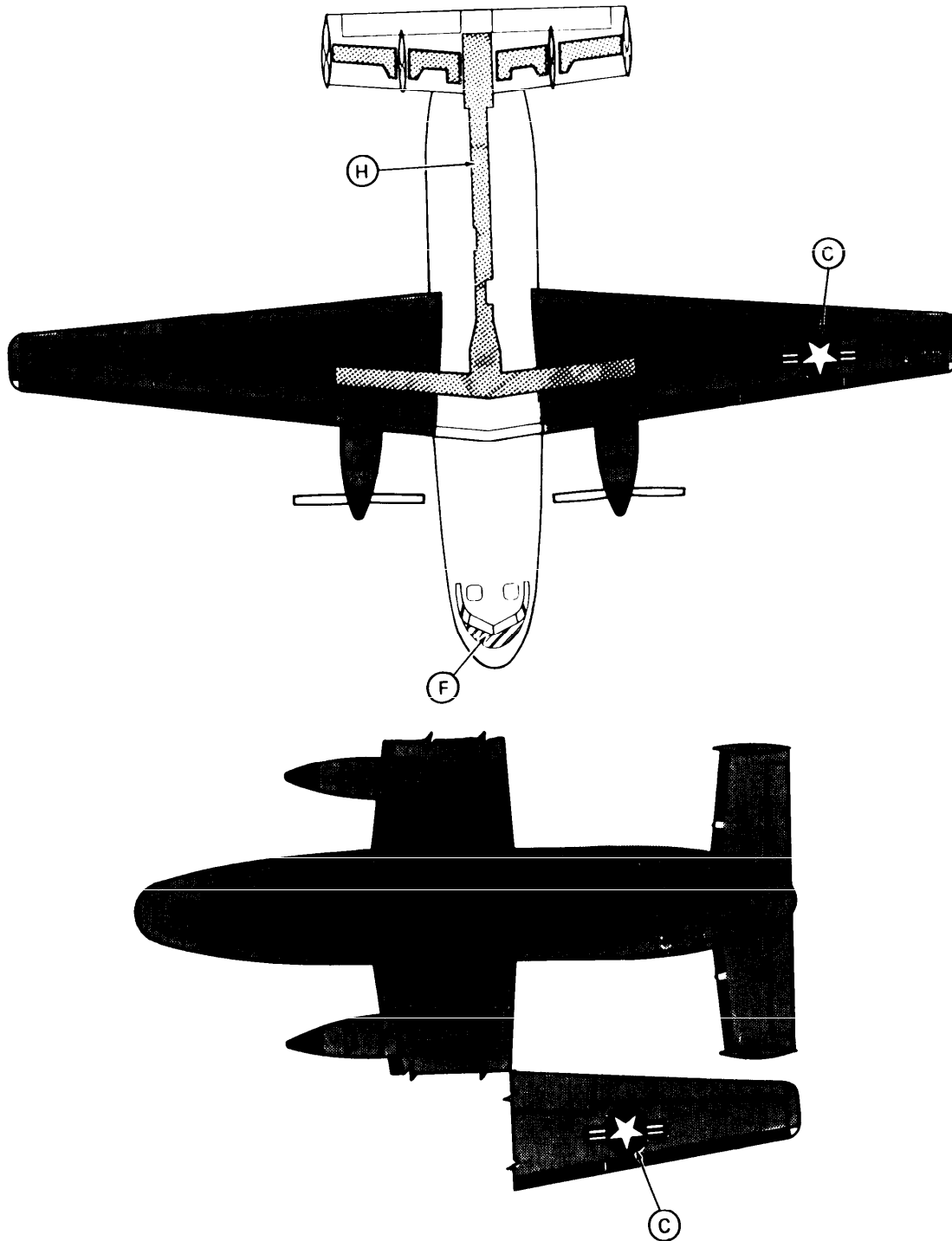


FIGURE C-8. C-2A aircraft marking - Continued.

MIL-STD-2161A(AS)

1. MARKING	2. LOCATION	3. SIZE	4. COLOR NO/CODE
A. UNITED STATES NAVY	Side of Fuselage	10"	17038
B. Model Designation, Acft BUNO	Aft Fuselage	2" 4"	17038
C. National Star	Aft Fuselage Upper L.H. Wing Lower R.H. Wing	45" 60" 60"	11136/15044/17925
D. Call Numbers	Vertical Stabilizer	20"	17038
E. Propeller Tips	N/A	3"/6"/3"	17925/11136/17925
F. Antiglare	Fwd. of Cockpit		37038
G. Navy	Lower L.H. Wing	36"	18464
H. Flap Wells, Aileron Wells and Aileron (See NOTE)			16440
I. Walkway Border	Wing Center to Outboard Engine	N/A	17038
J. Flag	Vertical Stabilizer	39"	11136/15044/ 17925 (Overseas only)
K. Unit Aircraft Numbers	Forward Fuselage	16"	17038
L. Unit Identifier	Vertical Stabilizer Upper R.H. Wing	40" 40"	17038 17038
M. Propeller Warning Band	Fwd. Fuselage	See Figure A-9	See Figure A-9
N. Rescue Arrow	Pilot Compartment Door Handle Rear Door Handle	29" 29"	17925/12197

NOTE: Item H - For tactical and LC aircraft, flap, wheel, and aileron wells shall be painted the appropriate color to blend with camouflage.

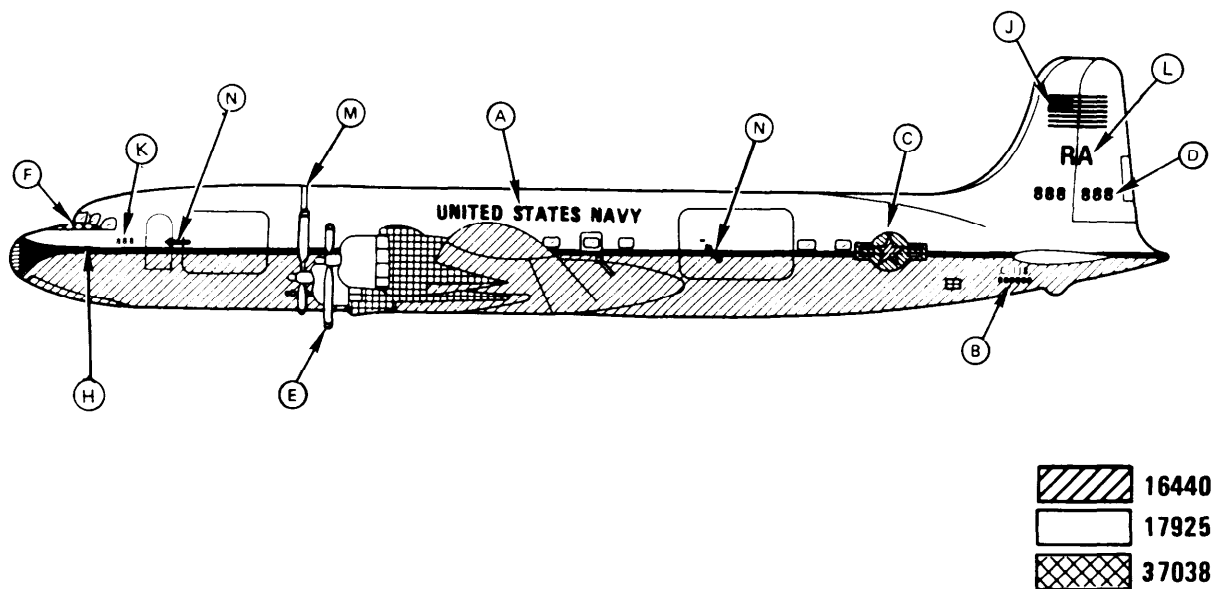


FIGURE C-9. C-118 aircraft marking (cargo).

MIL-STD-2161A(AS)

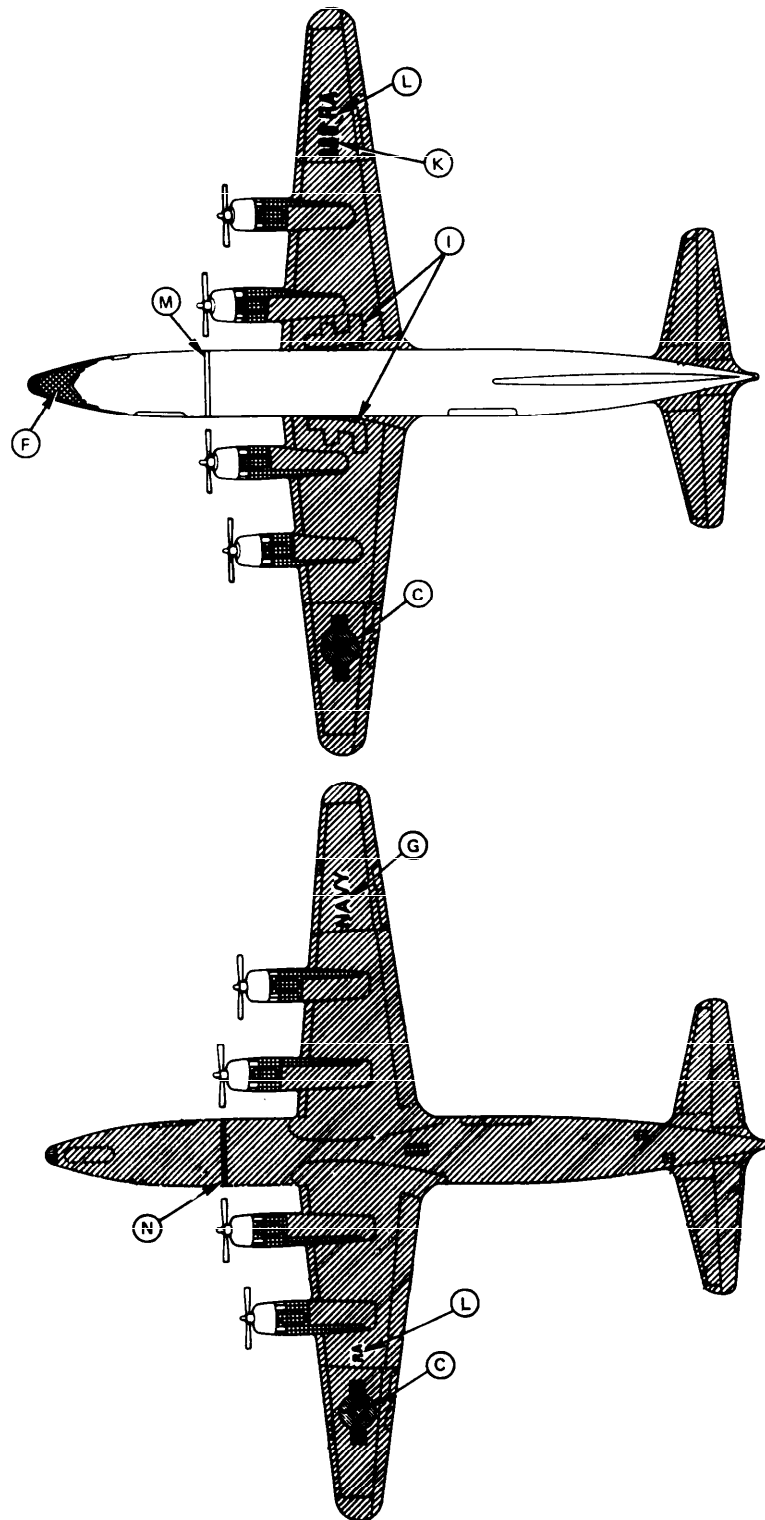


FIGURE C-9. C-118 aircraft marking (cargo) - Continued.

MIL-STD-2161A(AS)

1. MARKING	2. LOCATION	3. SIZE	4. COLOR NO/CODE
A. UNITED STATES NAVY	Center Fuselage	12"	17038
B. Model Designation, Acft BUNO	Aft Fuselage	2" 4"	17038
C. National Star	Aft Fuselage Lower R.H. Wing Upper L.H. Wing	55" 50" WG	11136 17925 15044
D. Call Numbers	Vertical Stabilizer	30"	17038
E. Propeller Tips	N/A	3"/6"/3"	17925/11136/17925
F. NAVY	Lower L.H. Wing	30"	17038
G. Walkway	Wing and Fuselage Upper Surface	N/A	36231
H. Conspicuity Markings	Per Drawing	N/A	12197
I. Propeller Warning Band	Fwd. Fuselage	3"	11136
J. Unit Aircraft Numbers	Fwd. Fuselage Upper R.H. Wing	24" 30"	17038
K. Unit Identifier	Lower R.H. Wing Upper R.H. Wing Vertical Stabilizer	30" 30" 30"/36"	17038
L. Antiglare	Nose	Per Drawing	17038
M. Emergency Rescue Notice	Wing/Fuselage Joint, R.H. & L.H. Sides	24"	13538
N. Turbine Exhaust Warning	Center Lower Fuselage, L.H. & R.H.	3"	11136

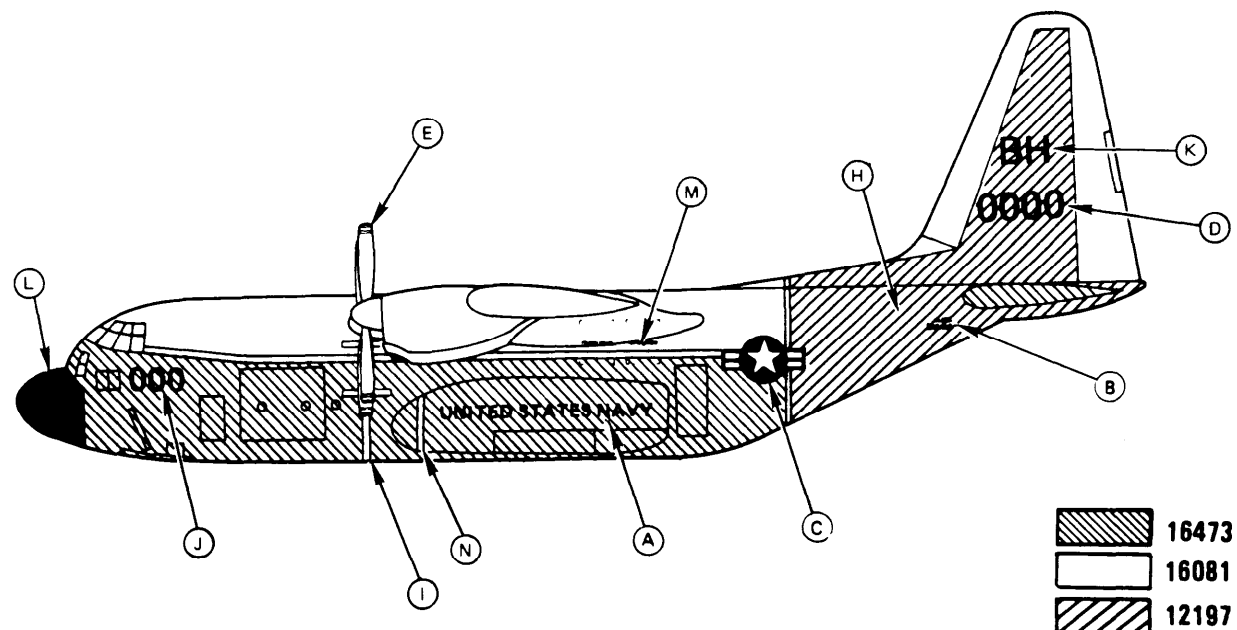


FIGURE C-10. C-130 aircraft marking (arctic).

MIL-STD-2161A(AS)

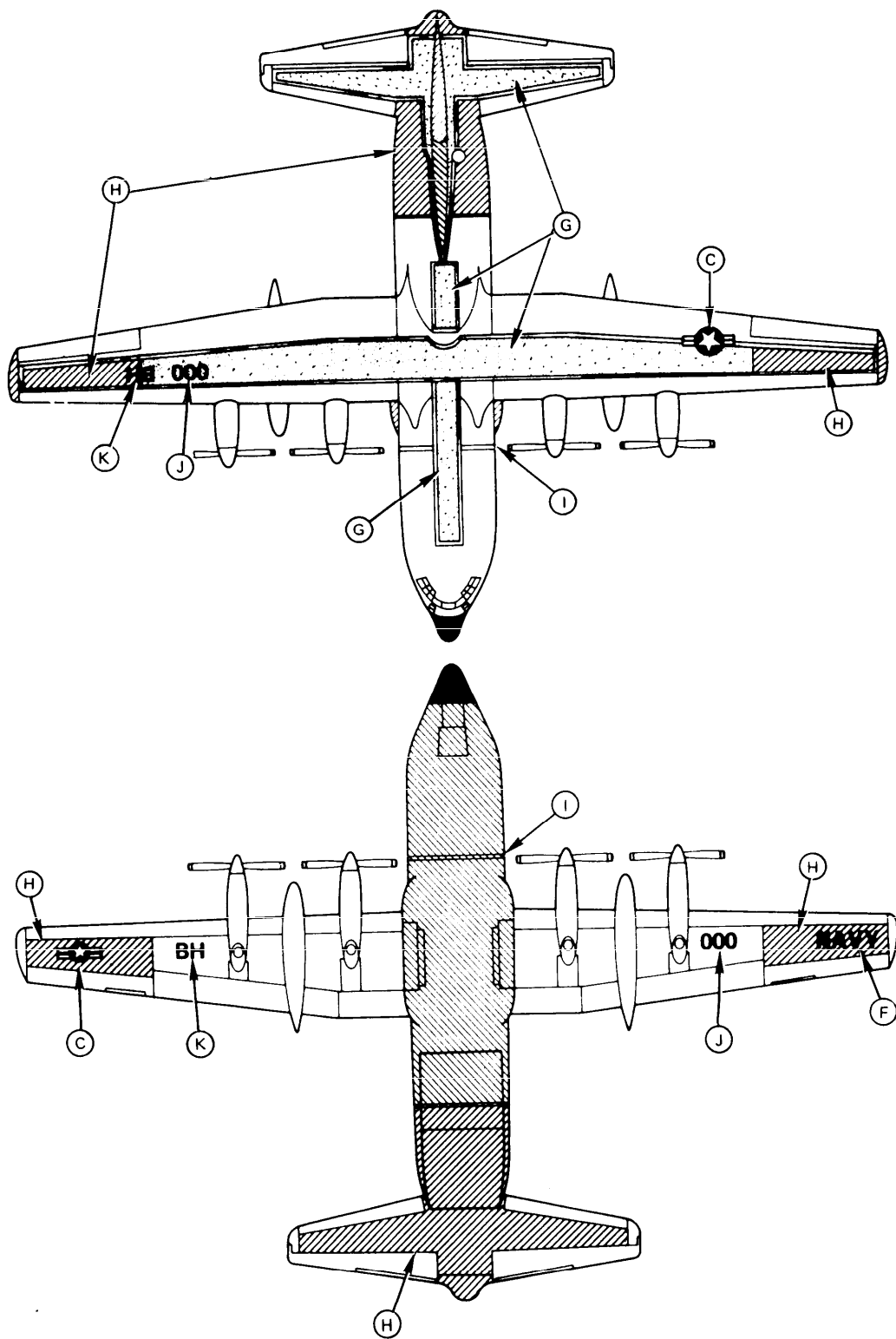
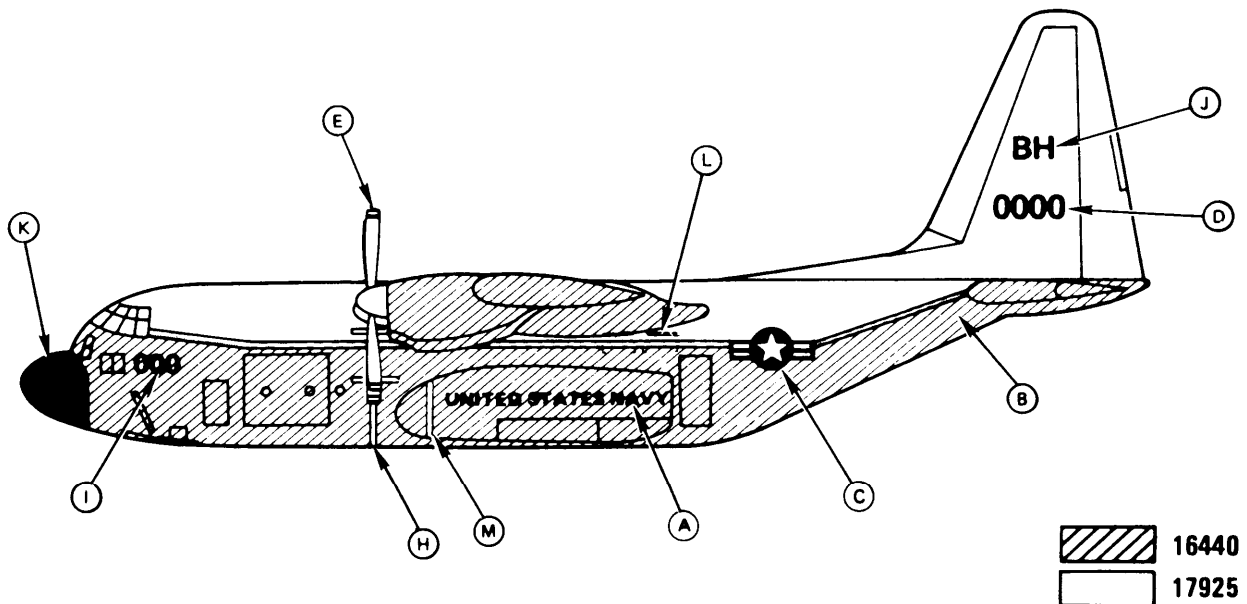


FIGURE C-10. C-130 aircraft marking (arctic) - Continued.

MIL-STD-2161A(AS)

1. MARKING	2. LOCATION	3. SIZE	4. COLOR NO/CODE
A. UNITED STATES NAVY/ MARINES	Center Fuselage	12"	17038
B. Model Designation, Acft BUNO	Aft Fuselage	2" 4"	17038
C. National Star	Aft Fuselage Lower R.H. Wing Upper L.H. Wing	55" 50" WG	11136 17925 15044
D. Call Numbers	Vertical Stabilizer	30"	17038
E. Propeller Tips	N/A	3"/6"/3"	17875/11136/17925
F. NAVY/MARINES	Lower L.H. Wing Wings	30"	17038
G. Walkway	Top of Wing & Fuselage	Per Drawing	36231
H. Propeller Warning Band	Fwd. Fuselage	3"	11136
I. Unit Aircraft Numbers	Fwd. Fuselage Upper R. H. Wing	24" 30"	17038
J. Unit Identifier	Lower R. H. Wing Upper R. H. Wing Vertical Stabilizer	30" 30" 30"/36"	17038
K. Antiglare	Nose	Per Drawing	17038
L. Emergency Rescue Notice	Wing/Fuselage Joint, R.H. & L.H. Sides	24"	13538
M. Turbine Exhaust Warning	Center Lower Fuselage, R.H. & L.H. Sides	3"	11136

FIGURE C-11. C-130 aircraft marking (cargo/tanker/tacamo).

MIL-STD-2161A(AS)

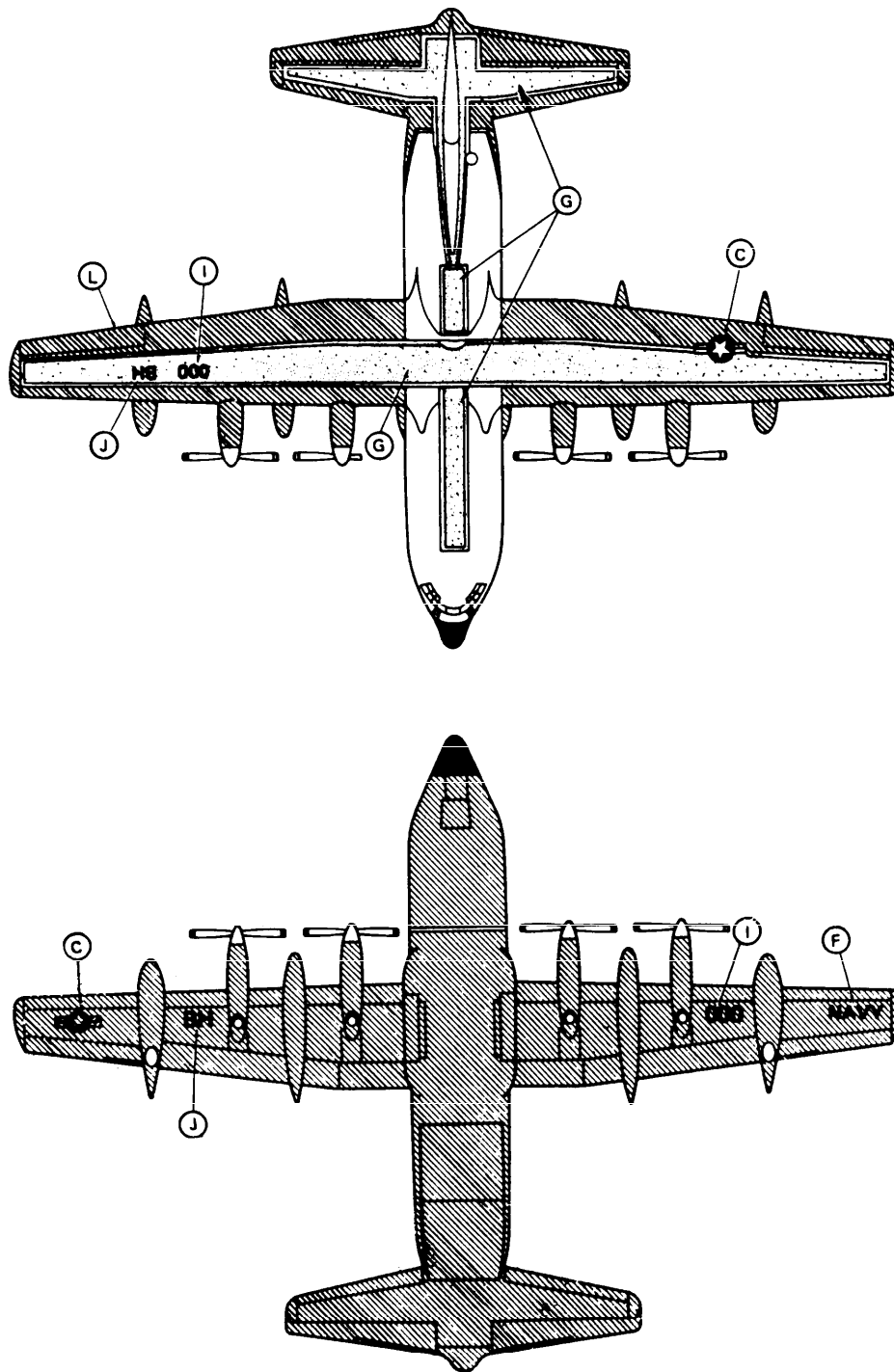


FIGURE C-11. C-130 aircraft marking (cargo/tanker/tacamo) - Continued.

MIL-STD-2161A(AS)

1. MARKING	2. LOCATION	3. SIZE	4. COLOR NO/CODE
A. UNITED STATES NAVY/ MARINES	Center Fuselage	12"	17038
B. Model Designation, Acft BUNO	Aft Fuselage	2" 4"	17038
C. National Star	Aft Fuselage Lower R.H. Wing Upper L.H. Wing	55" 50" WG	11136 17925 15044
D. Call Numbers	Vertical Stabilizer	30"	17038
E. Propeller Tips	N/A	3"/6"/3"	17875/11136/17925
F. NAVY/MARINES	Lower L.H. Wing Wings	30"	17038
G. Walkway	Top of Wing & Fuselage	Per Drawing	36231
H. Propeller Warning Band	Fwd. Fuselage	3"	11136
I. Unit Aircraft Numbers	Fwd. Fuselage Upper R. H. Wing	24" 30"	17038
J. Unit Identifier	Lower R. H. Wing Upper R. H. Wing Vertical Stabilizer	30" 30" 30"/36"	17038
K. Antiglare	Nose	Per Drawing	17038
L. Emergency Rescue Notice	Wing/Fuselage Joint, R.H. & L.H. Sides	24"	13538
M. Turbine Exhaust Warning	Center Lower Fuselage, R.H. & L.H. Sides	3"	11136

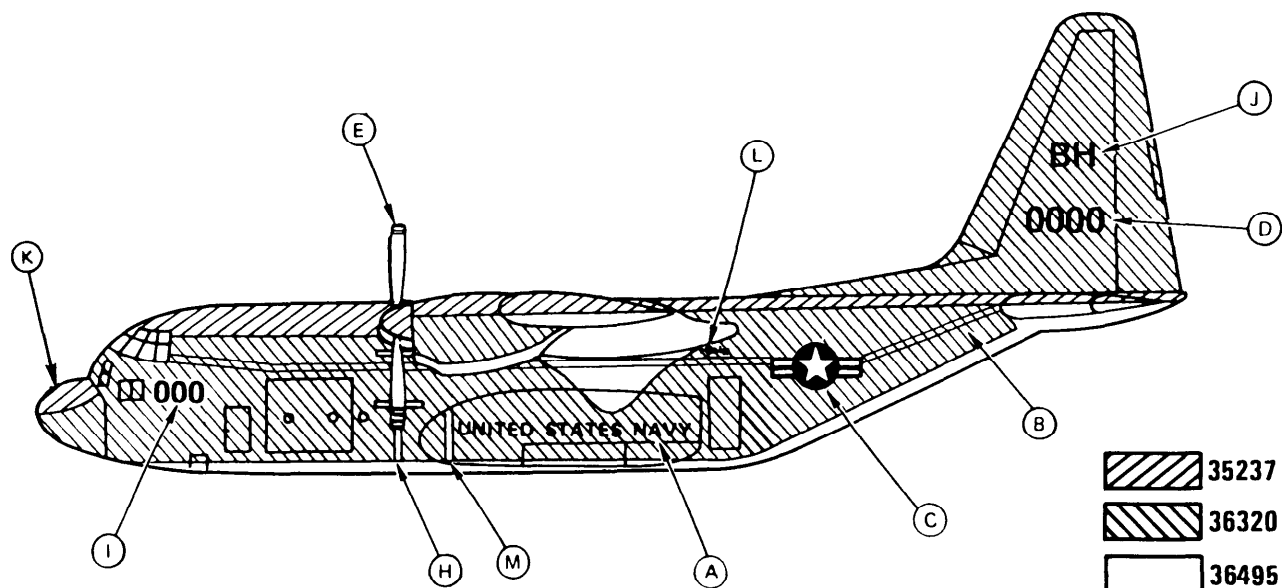


FIGURE C-12. C-130 aircraft marking (tactical).

MIL-STD-2161A(AS)

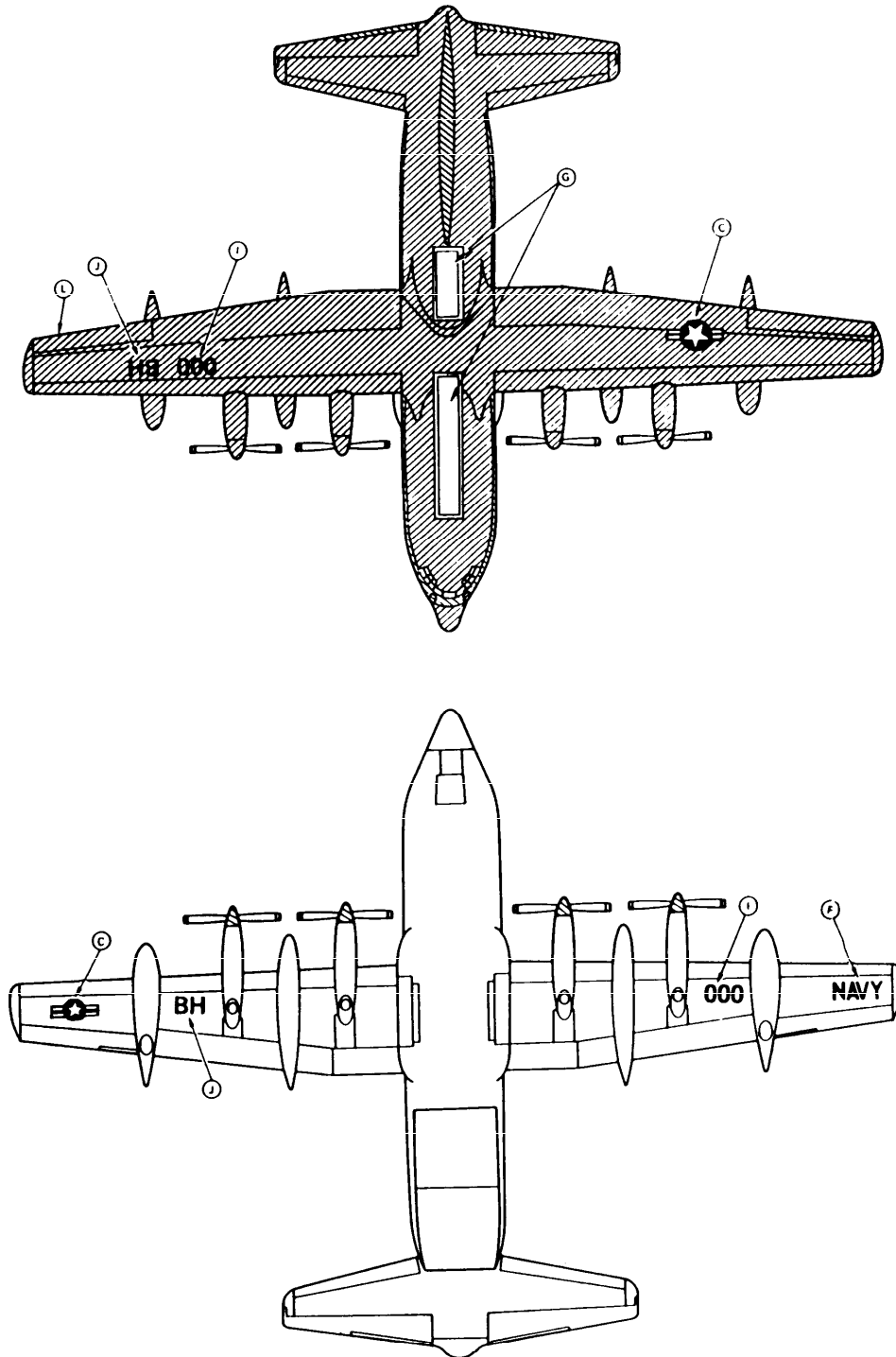


FIGURE C-12. C-130 aircraft marking (tactical) - Continued.

MIL-STD-2161A(AS)

1. MARKING	2. LOCATION	3. SIZE	4. COLOR NO/CODE
A. UNITED STATES NAVY	Fuselage	16"	17038
B. Model Designation, Acft BUNO	Aft Fuselage Under Horizontal Tail	2" 4"	17038
C. National Star	Aft Fuselage Upper L.H. Wing Lower R.H. Wing	40" 40" WG	11136 15044 17925
D. Call Numbers	Vertical Stabilizer	16"	17038
E. Propeller Tips	3"/6"/3"	12"	17875/11136/ 17925
F. Antiglare	Fwd. of Cockpit	N/A	37038
G. Unit Identifier	R.H. and L.H. Fwd. Fuselage	9"	17038
H. Propeller Warning Band	Lower Fuselage Propeller Plane	3"	11136/17925
I. Navy	Lower L.H. Wing	30"	17038
J. Walkway	Wings Near Fuselage	N/A	17038
K. Accent Stripe	Center of Fuselage L.H. & R.H. Sides Nose to Horizontal Stabilizer	2.5"	17925
L. Rescue Arrow	Fwd. Fuselage	24"	17038

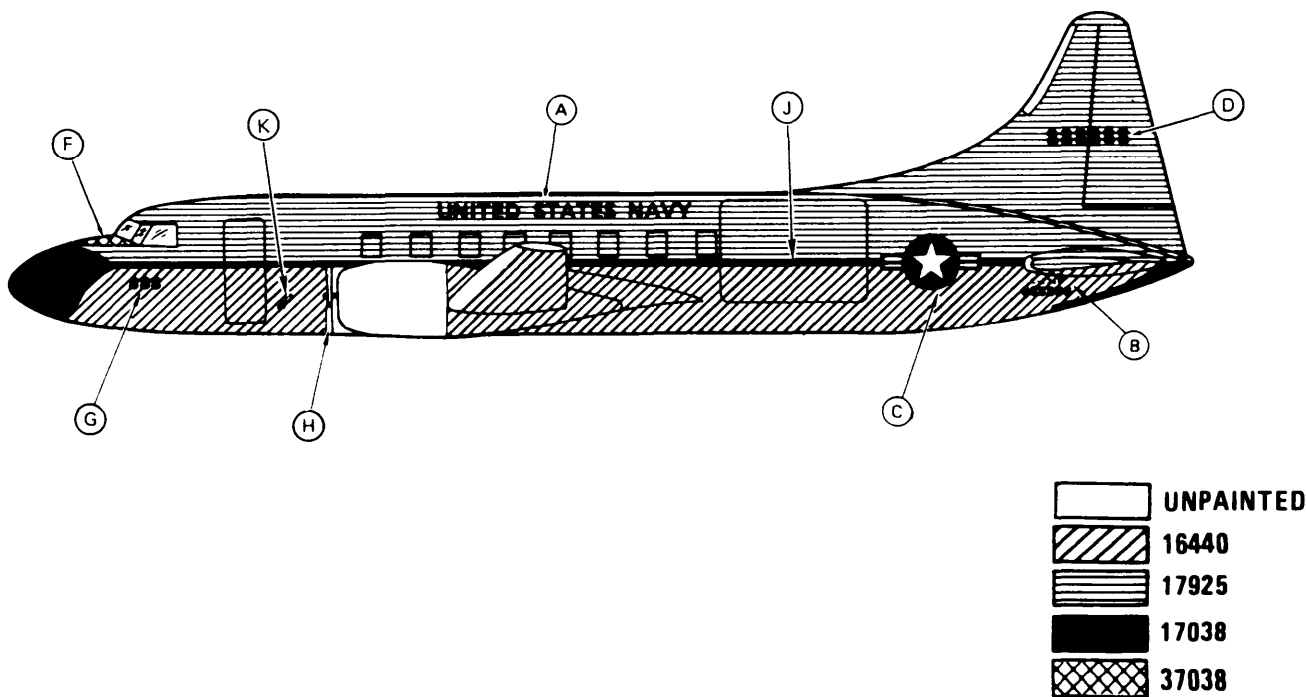


FIGURE C-13. C-131 aircraft marking (cargo).

MIL-STD-2161A(AS)

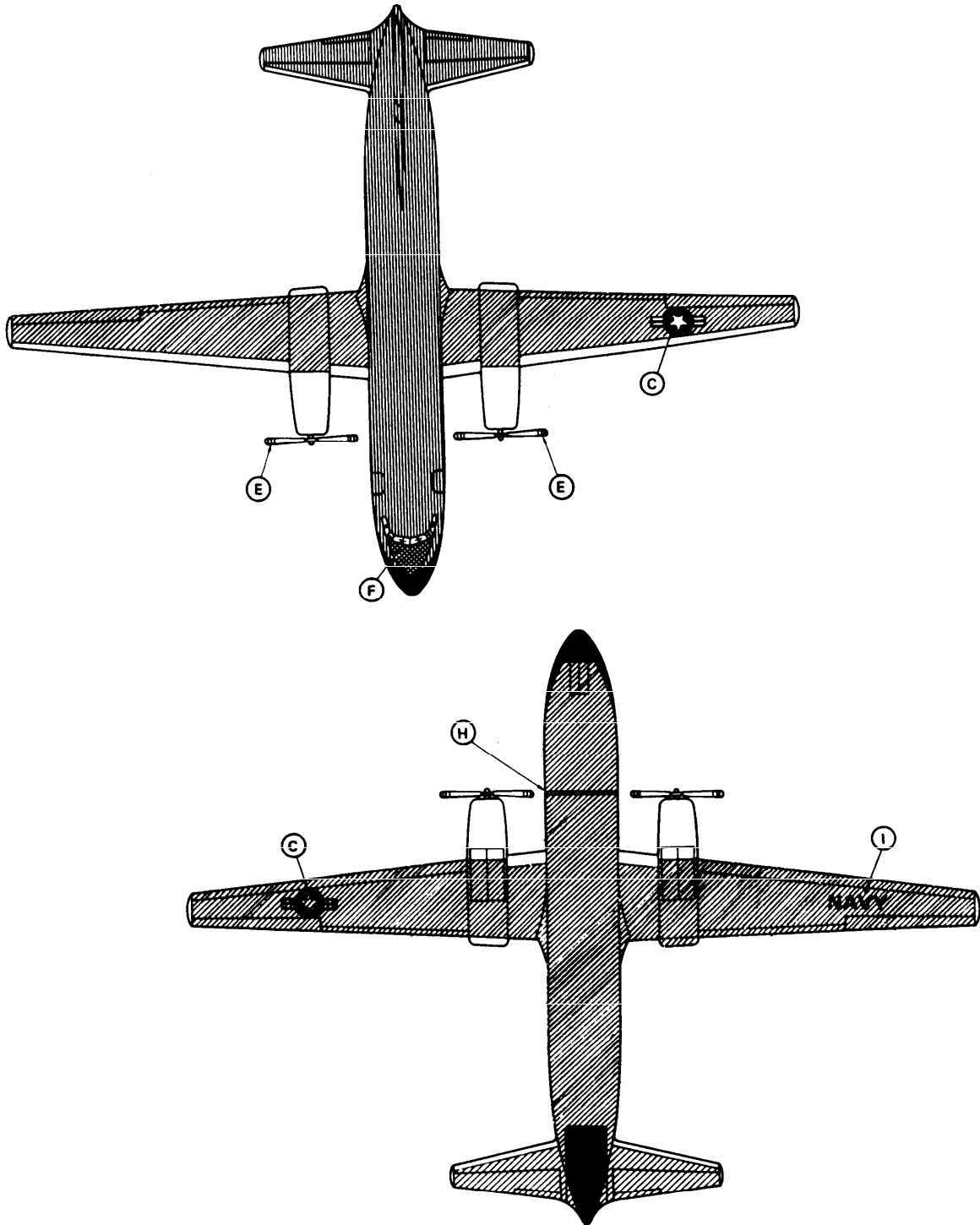
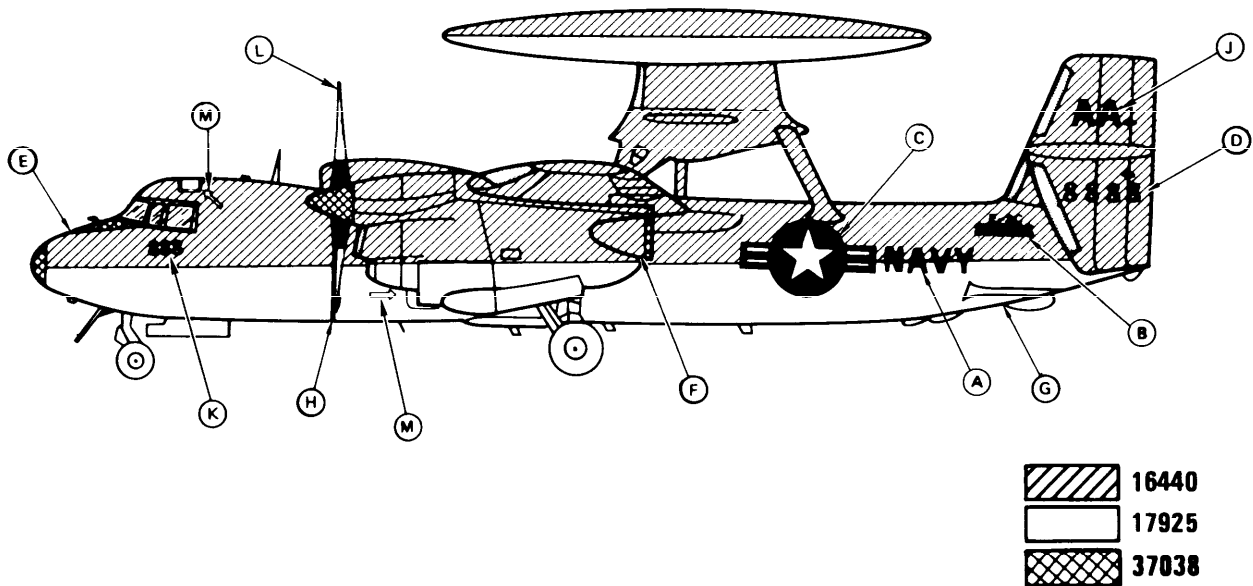


FIGURE C-13. C-131 aircraft marking (cargo) - Continued.

MIL-STD-2161A(AS)

1. MARKING	2. LOCATION	3. SIZE	4. COLOR NO/CODE
A. NAVY	Aft Fuselage	20"	17038
B. Model Designation, Acft BUNO	Aft Fuselage	2" 4"	17038
C. National Star	Aft Fuselage Upper L.H. Wing Lower R. H. Wing	40" 40" 40"	11136 15044 17925
D. Call Numbers	Vertical Stab	12"	17038
E. Antiglare	Fwd. of Cockpit	N/A	37038
F. Beware of Blast	Engine Exhaust Cowling	12"	17038
G. Arresting Hook Marking	Aft Fuselage	7"	17038
H. Propeller Warning Band	Fwd. Fuselage	3"	11136/17925
I. Walkway	Top Horizontal Tail Surface Top Center of Wing	N/A	IAW Para. 5.1.13
J. Unit Identifier	Vertical Stabilizer	30"/36"	17038
K. Unit Aircraft Numbers	Fwd. Fuselage	24"	17038
L. Propeller Tips	N/A	3"/6"/3"	17925/11136/17925
M. Rescue Arrow	L.H. Side Fuselage Near Door Top Fwd. Fuselage Aft of Cockpit	24"	13538 17038

FIGURE C-14. E-2C aircraft marking.

MIL-STD-2161A(AS)

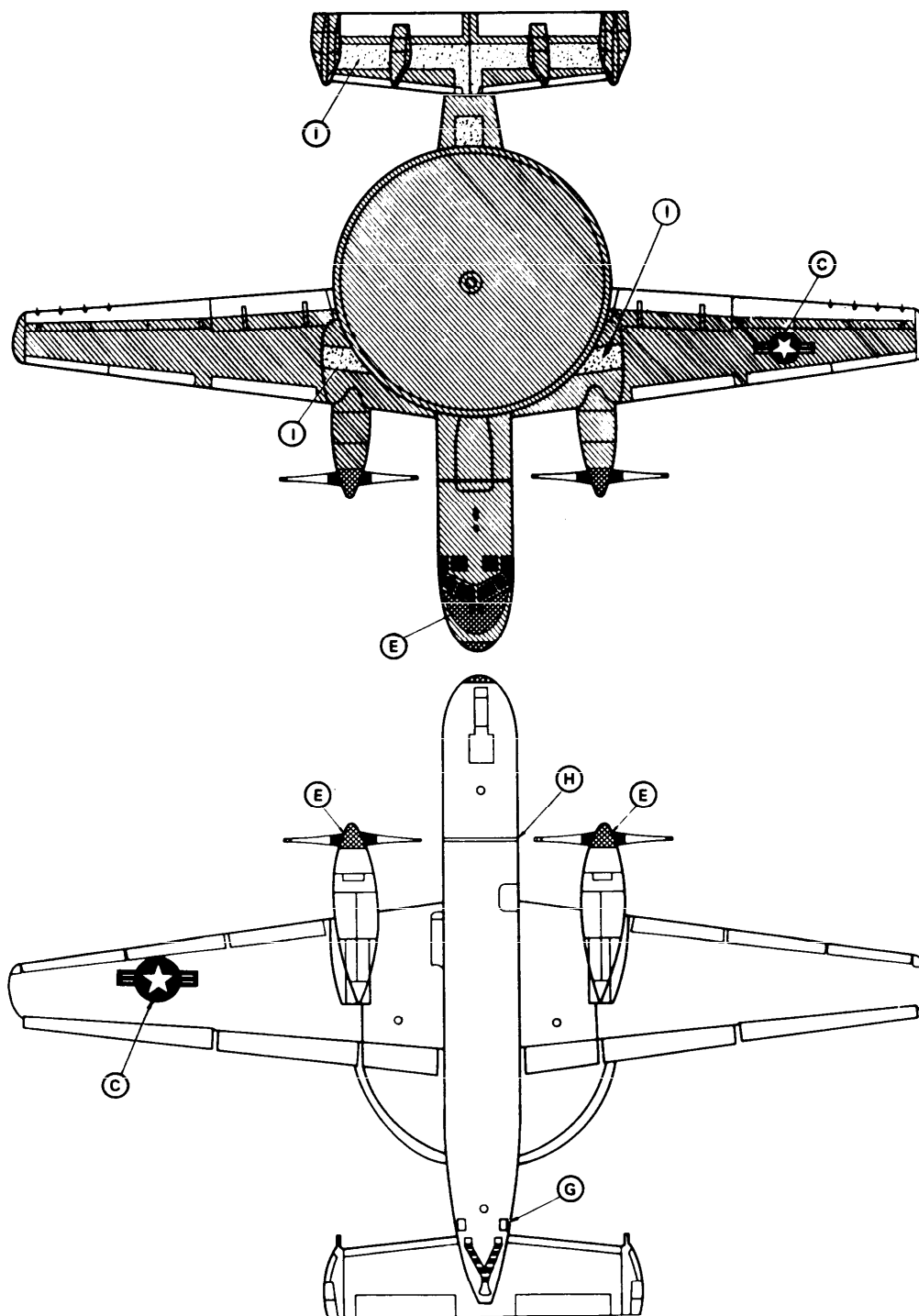


FIGURE C-14. E-2C aircraft marking - Continued.

MIL-STD-2161A(AS)

1. MARKING	2. LOCATION	3. SIZE	4. COLOR NO/CODE
A. NAVY	Aft Fuselage	12"	IAW Para. 5.2.3 & Figure A-15
B. Model Designation, Acft BUNO	Below National Star	2" 4"	IAW Para. 5.2.3 & Figure A-15
C. National Star	Aft Fuselage Upper L. H. Wing Lower R. H. Wing	12" 12" 12"	IAW Para. 5.2.3 & Figure A-1
D. Call Numbers	Lower Vertical Stabilizer	12"	IAW Para. 5.2.3
E. Intake Warning	Engine Intake Nacelles	See 5.2.2.10.1	IAW Para. 5.2.3 & Figure A-15
F. Beware of Blast	Aft Engine Exhaust Outlet	15"	IAW Para. 5.2.3
G. Arresting Hook Marking	Aft Fuselage	13"	IAW Para. 5.2.3 & Figure A-14
H. Ejection Seat Warning	Below Canopy Rail	8"	IAW Para. 5.2.3 & Figure A-16
I. Walkway	Wings Next to Fuselage	N/A	IAW Para. 5.1.13
J. Unit Identifier	Upper R. H. Wing Vertical Stabilizer	30" 30"	IAW Para. 5.2.3
K. Unit Aircraft Numbers	Forward Fuselage Upper R. H. Wing	12" 24"	IAW Para. 5.2.3
L. Rescue Arrow	R.H. & L.H. Sides of Fuselage Aft of Intake Warning	24"	IAW Para. 5.2.3 & Figure A-14

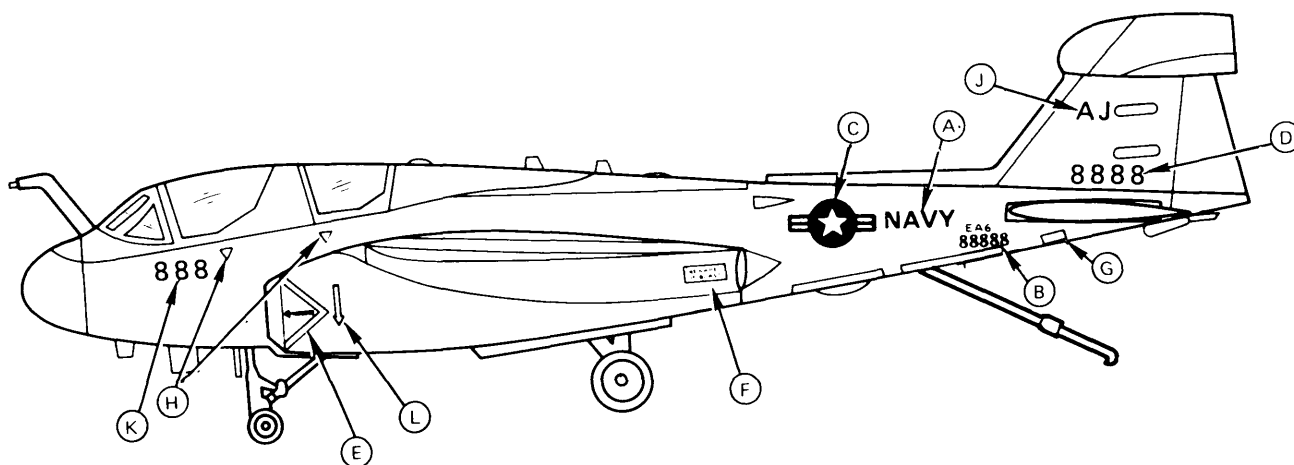


FIGURE C-15. EA-6B aircraft marking (tactical).

MIL-STD-2161A(AS)

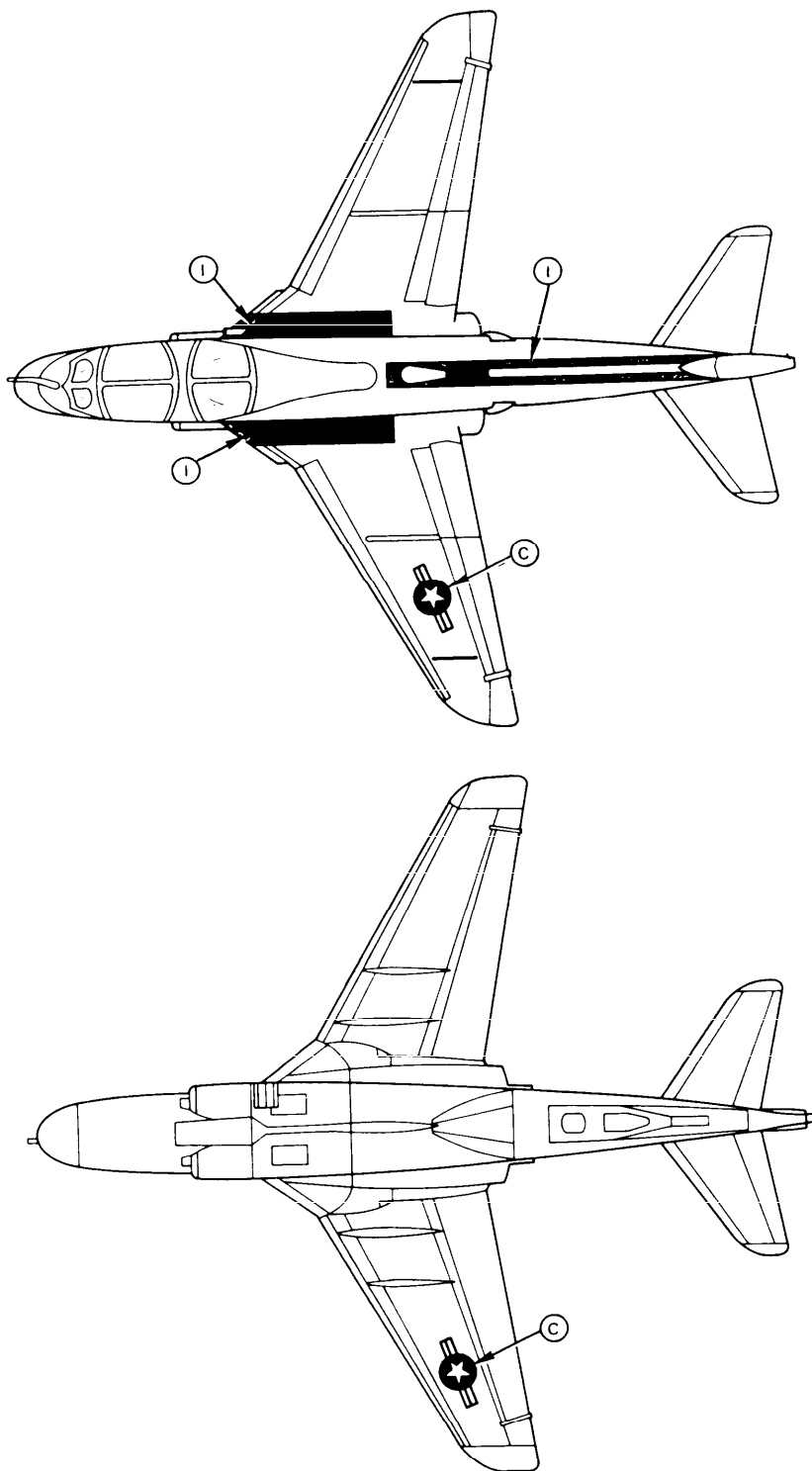
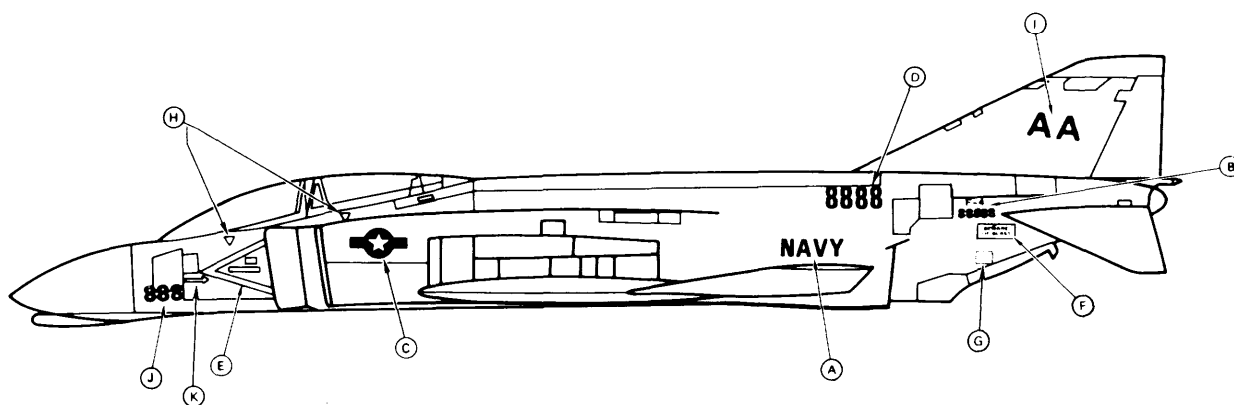


FIGURE C-15. EA-6B aircraft marking (tactical) - Continued.

MIL-STD-2161A(AS)

1. MARKING	2. LOCATION	3. SIZE	4. COLOR NO/CODE
A. NAVY/MARINES	Aft Fuselage	12"	IAW Para. 5.2.3 & Figure A-15
B. Model Designation, Acft BUNO	Aft Fuselage	2" 4"	IAW Para. 5.2.3 & Figure A-15
C. National Star	Fwd. Fuselage Upper L.H. Wing Lower R.H. Wing	12" 12" 12"	IAW Para. 5.2.3 & Figure A-14
D. Call Numbers	Aft Fuselage	12"	IAW Para. 5.2.3
E. Intake Warning	Engine Intake Nacelles	33"	IAW Para. 5.2.3 & Figure A-15
F. Beware of Blast	Aft Fuselage	9"	IAW Para. 5.2.3
G. Arresting Hook Marking	Aft Fuselage	13"	IAW Para. 5.2.3 & Figure A-14
H. Ejection Seat Warning	Below Canopy Rail	8"	IAW Para. 5.2.3 & Figure A-16
I. Unit Identifier	Vertical Stabilizer	12"	IAW Para. 5.2.3
J. Unit Aircraft Numbers	Fwd. Fuselage	12"	IAW Para. 5.2.3
K. Rescue Arrow	R.H. & L.H. Sides of	18"	IAW Para. 5.2.3
L. Walkway	Wings Next to Fuselage	N/A	IAW Para. 5.1.13

FIGURE C-16. RF/F-4 aircraft marking (tactical).

MIL-STD-2161A(AS)

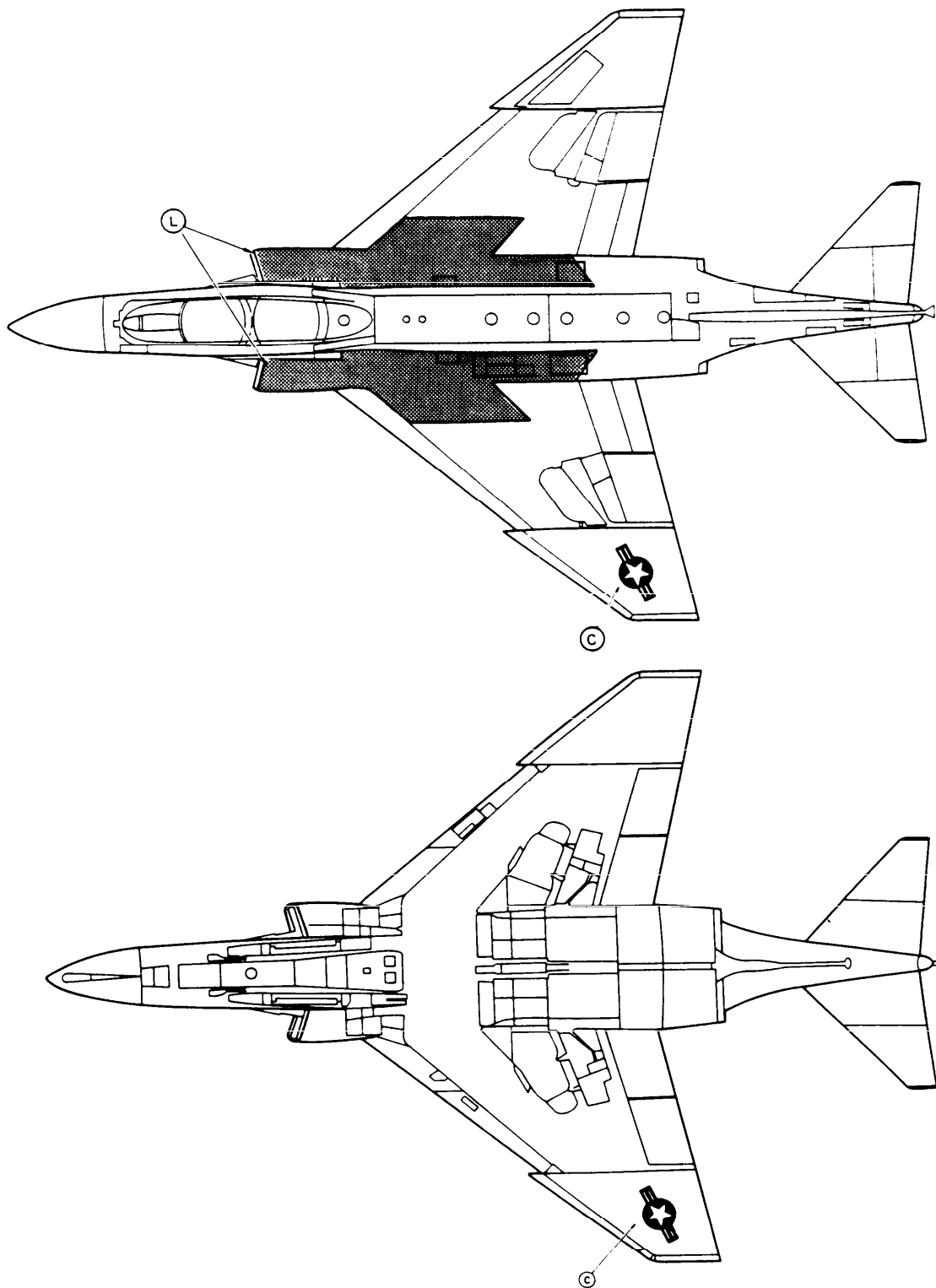


FIGURE C-16. RF/F-4 aircraft marking (tactical) - Continued.

MIL-STD-2161A(AS)

1. MARKING	2. LOCATION	3. SIZE	4. COLOR NO/CODE
A. NAVY	Aft Fuselage	12"	IAW Figure A-15, 35237
B. Model Designation, Acft BUNO	Aft Fuselage	2" 4"	IAW Figure A-15, 35237
C. National Star	Forward Fuselage Upper L. H. Wing Lower R. H. Wing	12"	IAW Figure A-1, 35237
D. Call Numbers	Vertical Stabilizer	12"	35237
E. Beware of Blast	Aft Fuselage	12"	IAW Figure A-8, 35237
F. Arresting Hook Marking	Aft Fuselage		IAW Figure A-14, 35237
G. Ejection Seat Warning	Below Canopy Rail	8"	IAW Figure A-16, 35237
H. Walkway	Aft Fuselage Next to Vertical Stabilizer	N/A	IAW Para. 5.2.3 36320
I. Intake Warning	Nose		IAW Figure A-15, 35237
J. Unit Identifier	Vertical Stabilizer		IAW 35237
K. Unit Aircraft Numbers	Fwd. Fuselage		IAW Para. 5.2.3
L. Rescue Arrow	R.H. & L.H. Side of Canopy	24"	IAW Figure A-14, 35237

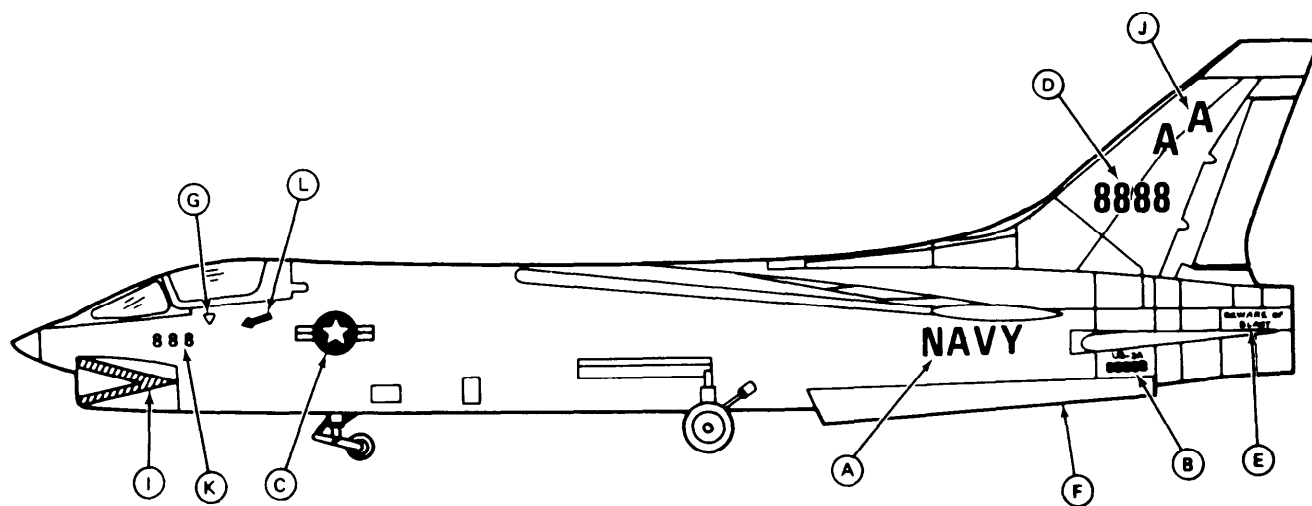


FIGURE C-17. RF-8G aircraft marking (tactical).

MIL-STD-2161A(AS)

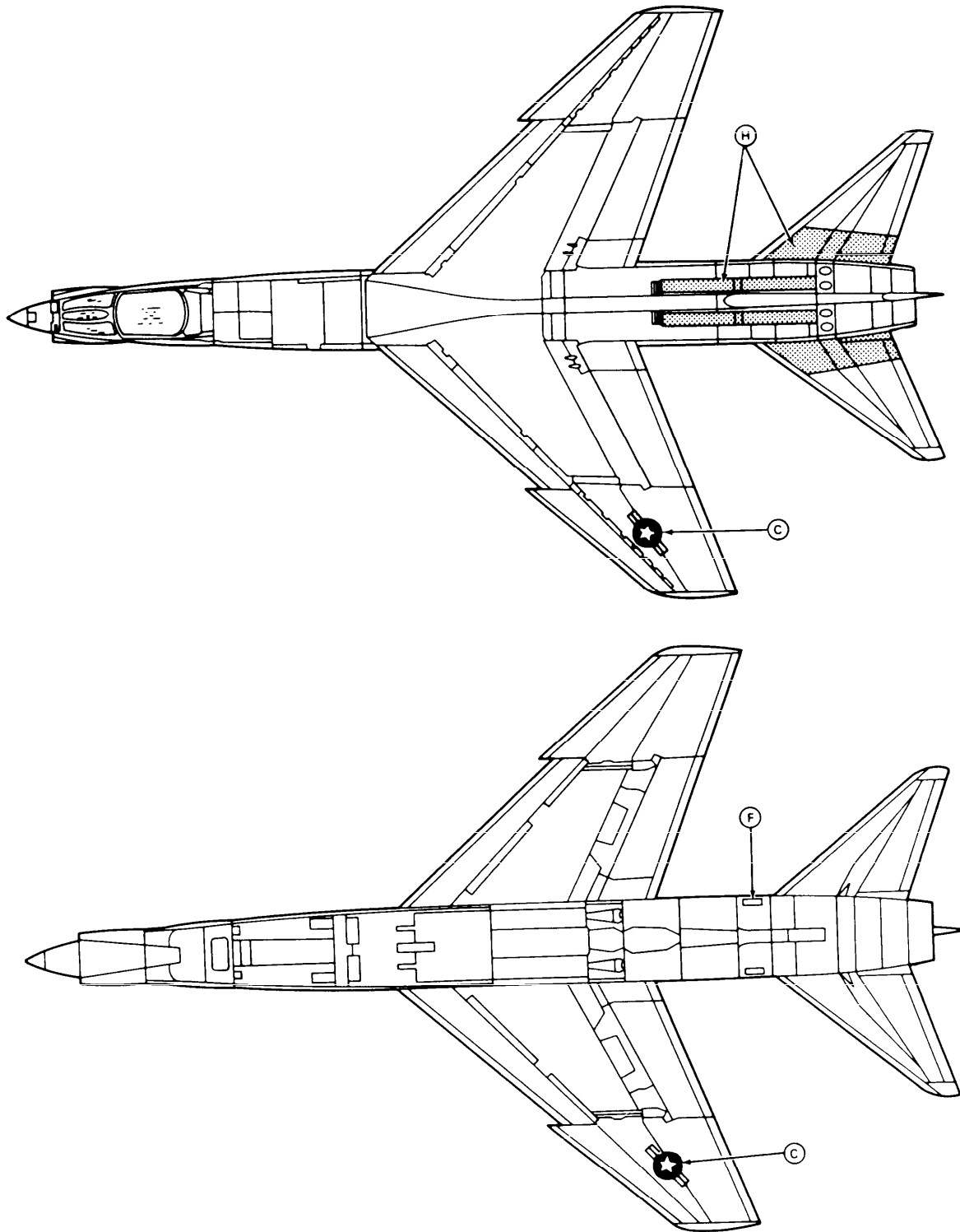


FIGURE C-17. RF-8G aircraft marking (tactical) - Continued.

MIL-STD-2161A(AS)

1. MARKING	2. LOCATION	3. SIZE	4. COLOR NO/CODE
A. NAVY	Aft Fuselage	12"	IAW Para. 5.2.3 & Figure A-15
B. Model Designation, Acft BUNO	Aft Side Fuselage	2" 6"	IAW Para. 5.2.3 & Figure A-15
C. National Star	Fwd. Side Fuselage L.H. Wing Top R.H. Wing Bottom	12"	IAW Para. 5.2.3 & Figure A-14
D. Intake Warning	Forward Engine Intake	75"	IAW Para. 5.2.3 & Figure A-15
E. Beware of Blast	Lower Aft Side Fuselage	12"	IAW Para. 5.2.3
F. Call Numbers	Outside Vertical Tails	12"	IAW Para. 5.2.3
G. Unit Aircraft Number	Fwd. Fuselage	12" 24"	IAW Para. 5.2.3
H. Unit Identifier	Outside Vertical Stabilizer	30"	IAW Para. 5.2.3
I. Arresting Hook Marking	Aft Fuselage	8"	IAW Para. 5.2.3 & Figure A-14
J. Walkway	Wing Near Rear Canopy and Rear Wheels	N/A	IAW Para. 5.1.13
K. Ejection Seat Warning	Below Canopy Rail (2 places)	8"	IAW Para. 5.2.3 & Figure A-16
L. Rescue Arrow	R.H. & L.H. Sides of Fuselage	24"	IAW Para. 5.2.3 & Figure A-14

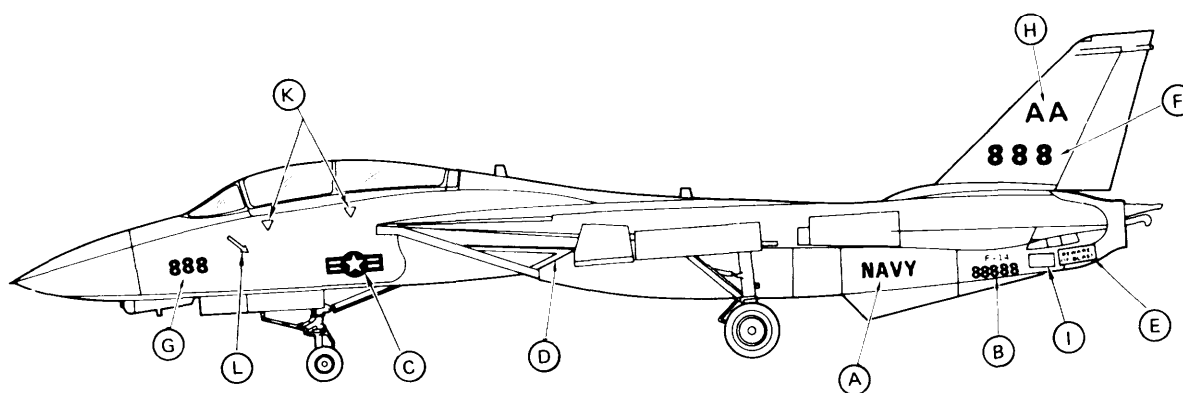


FIGURE C-18. F-14 aircraft marking (tactical).

MIL-STD-2161A(AS)

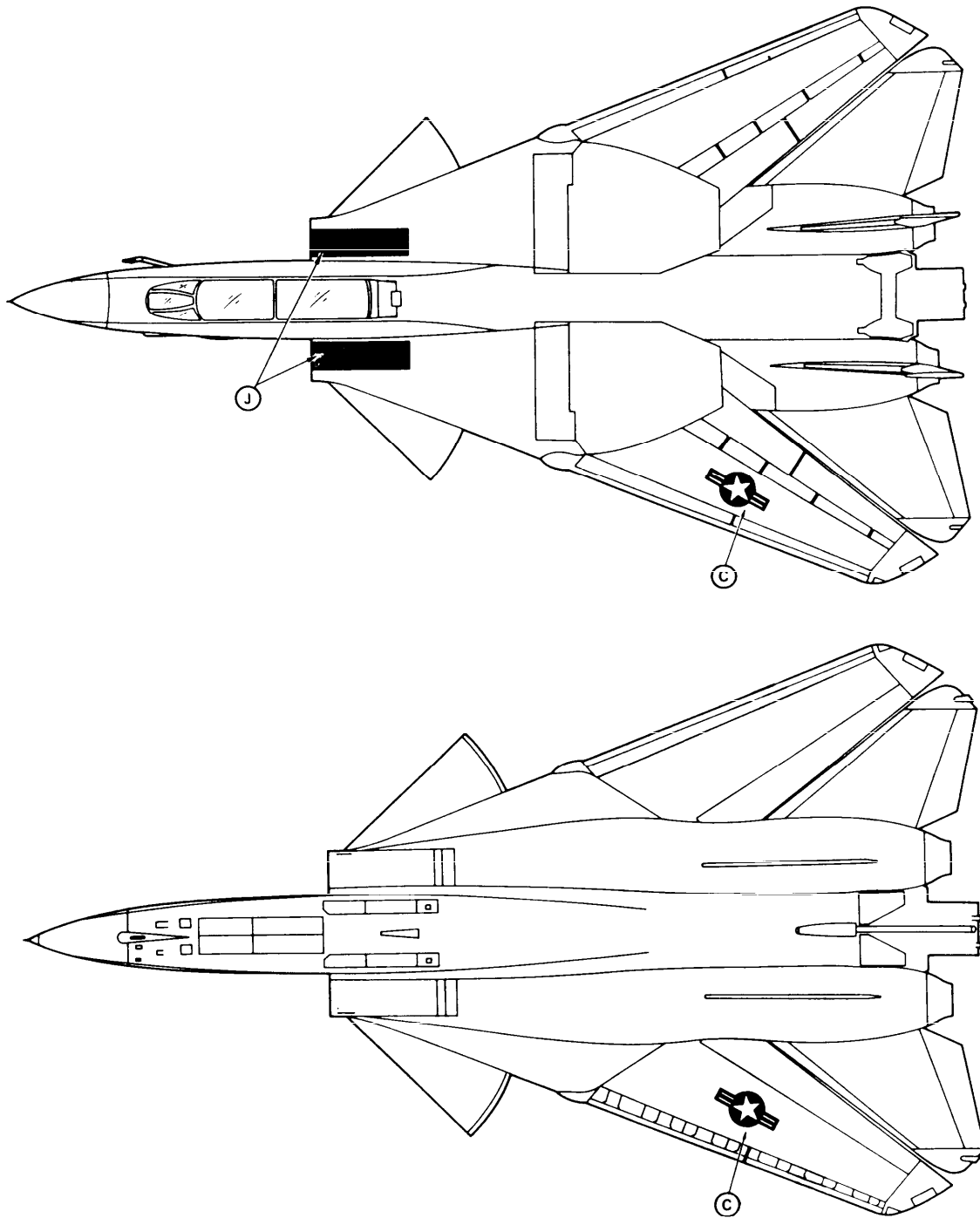
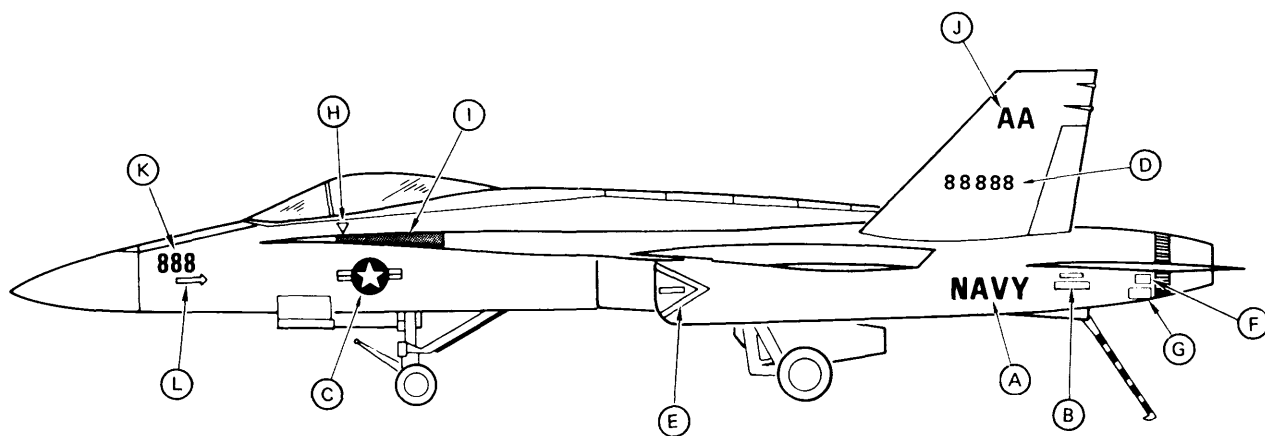


FIGURE C-18. F-14 aircraft marking (tactical) - Continued.

MIL-STD-2161A(AS)

1. MARKING	2. LOCATION	3. SIZE	4. COLOR NO/CODE
A. NAVY/MARINES	Aft Fuselage	12"/10"	IAW Figure A-15, 35237
B. Model Designation, Acft BUNO	Aft Fuselage	4" 2"	IAW Figure A-15, 35237
C. National Star	Fwd. Fuselage Lower L.H. Wing Upper L.H. Wing	12" 12" 12"	IAW Figure A-1, 35237
D. Call Numbers	Outside Vertical Stabilizers	10"	35237
E. Intake Warning	Fwd. Engine Intake	75"	IAW Figure A-15, 35237
F. Beware of Blast	Aft Fuselage	12"	35237
G. Arresting Hook Marking	Aft Fuselage	14"	IAW Figure A-14, 35237
H. Ejection Seat Warning	Upper Canopy Rail	8"	IAW Figure A-16, 35237
I. Walkway	L.H. Fuselage	N/A	IAW Para. 5.1.13
J. Unit Identifier	Outside Vertical Stabilizers	30"	35237
K. Unit Aircraft Numbers	Fwd. Fuselage	12"	IAW Para. 5.2.3
L. Rescue Arrow	Fwd. Fuselage	24"	IAW Figure A-14, 35237

FIGURE C-19. F-18 aircraft marking (tactical).

MIL-STD-2161A(AS)

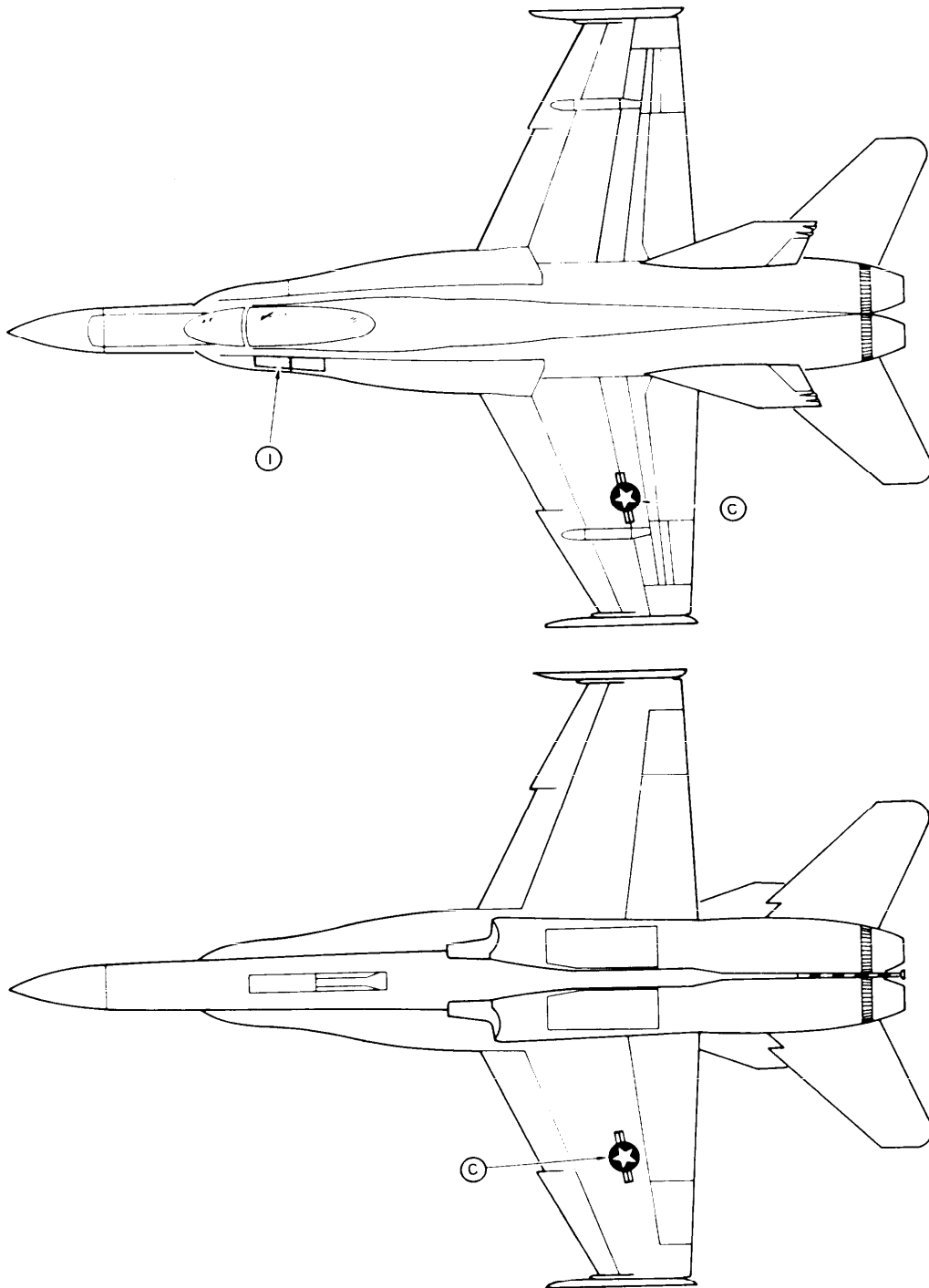


FIGURE C-19. F-18 aircraft marking (tactical) - Continued.

MIL-STD-2161A(AS)

1. MARKING	2. LOCATION	3. SIZE	4. COLOR NO/CODE
A. MARINES	R.H. and L.H. of Tail Boom	10"	IAW Para 5.2.3.2
B. Model Designation, Acft BUONO	Tail Boom R.H. and L.H.	2" 6"	IAW Para 5.2.3.2
C. National Star	R.H. and L.H. Side	15" 15" 15"	IAW Para 5.2.3.2 IAW Para 5.2.3.2
D. No Push	R.H. and L.H. Side, Aft Tail Boom Fairing, Fwd. and Aft of Elevators		IAW Para 5.2.3.2
E. Intake Warning	Fwd. of Intakes	15"	IAW Para 5.2.3.2
F. Beware of Blast	R.H. and L.H. Side	5"	IAW Para 5.2.3.2
G. Tail Rotor Warning	Tail Boom	22"	IAW Para 5.2.3.2
H. Walkway		24" x 6"	35237
I. Rescue Arrow	R.H. and L.H. Side of Nose Section	2"	IAW Para 5.2.3.2
J. Rescue Arrow	Adjacent to Pilots and Gunners Door Handles	3/4"	IAW Para 5.2.3.2
K. Unit Aircraft Numbers	R.H. and L.H. of Nose Section	10"	IAW Para 5.2.3.2
L. Unit Identifier	R.H. and L.H. Side	10"	IAW Para 5.2.3.2

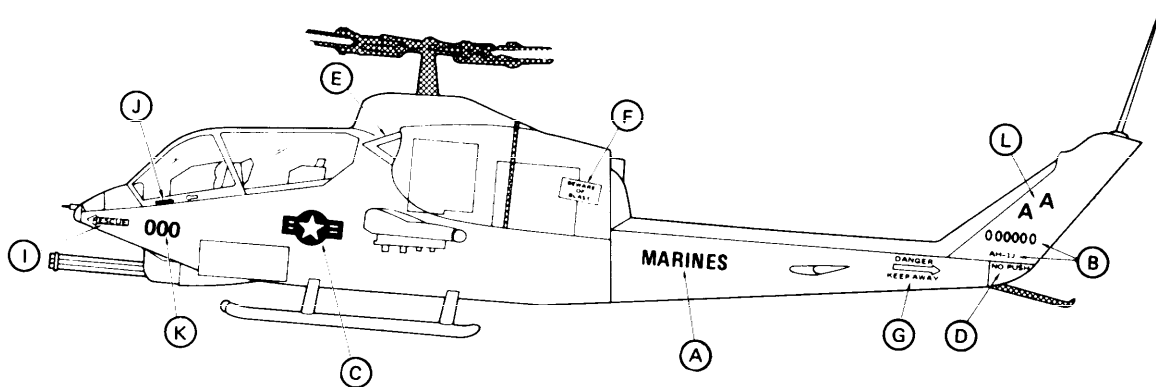


FIGURE C-20. AH-1J/1T/1W aircraft marking (tactical).

MIL-STD-2161A(AS)

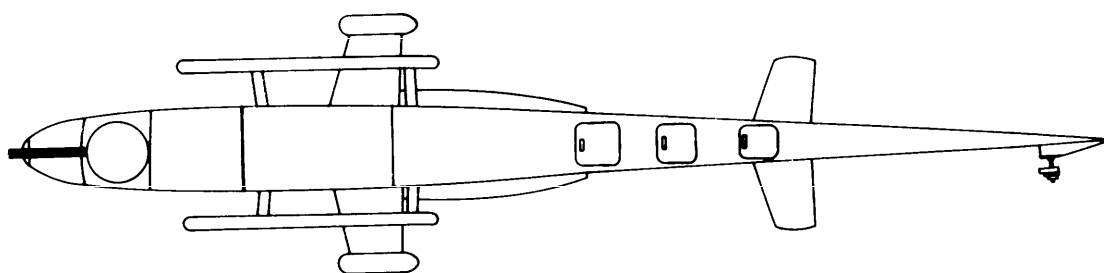
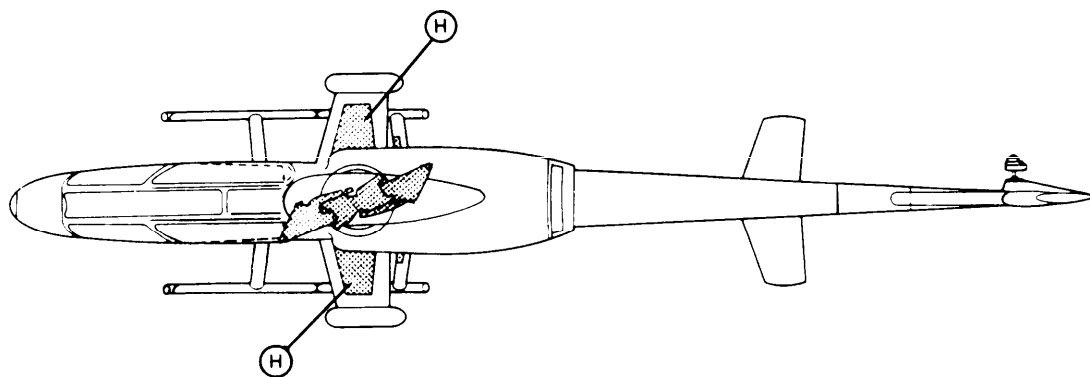


FIGURE C-20. AH-1J/1T/1W aircraft marking (tactical) - Continued.

MIL-STD-2161A(AS)

1. MARKING	2. LOCATION	3. SIZE	4. COLOR NO/CODE
A. NAVY	Bottom & Sides Fuselage	10" 10"	17038/17925
B. Model Designation, Acft BUNO	Tail Boom L.H. & R.H. Sides	2" 6"	17925
C. National Star	Center Fuselage Bottom Fuselage Top Fuselage	15" 15" 15"	17925 11136 15044
D. Rescue Arrow	Cockpit Door	24"	13538/17038
E. Call Numbers	Tail Boom	6"	17038
F. Intake Warning	Engine Inlet Nacelle	15"	11136/17925
G. Beware of Blast	Engine Exhaust Nacelle	8"	11136/17925
H. Tail Rotor Warning	Aft Fuselage	33"	13538/11136/17038
I. Rescue	Bottom & Top Fuselage	10"	*17925/17038
J. Abandon Chute	Bottom Fuselage	10"	17925
K. Conspicuity Markings	Per Drawing	N/A	12197
L. Unit Identifier	Bottom Aft Fuselage Tail Boom	10"	17925/17038
M. Unit Aircraft Numbers	Both Doors & Nose Bottom Aft Fuselage	10"	17925
N. Antiglare	Fwd. of Windscreen	N/A	37038

* 17925 on Orange Background, 17038 on Gray Background

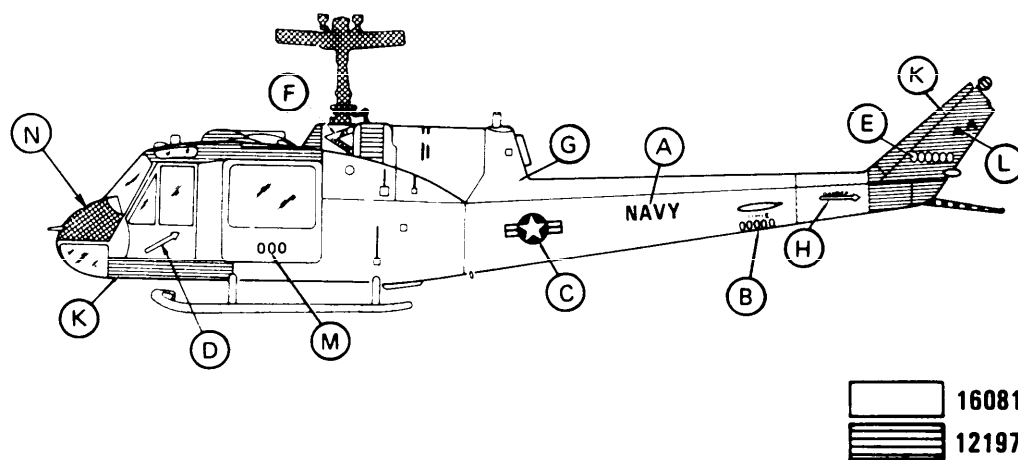


FIGURE C-21. UH-1E aircraft marking (SAR).

MIL-STD-2161A(AS)

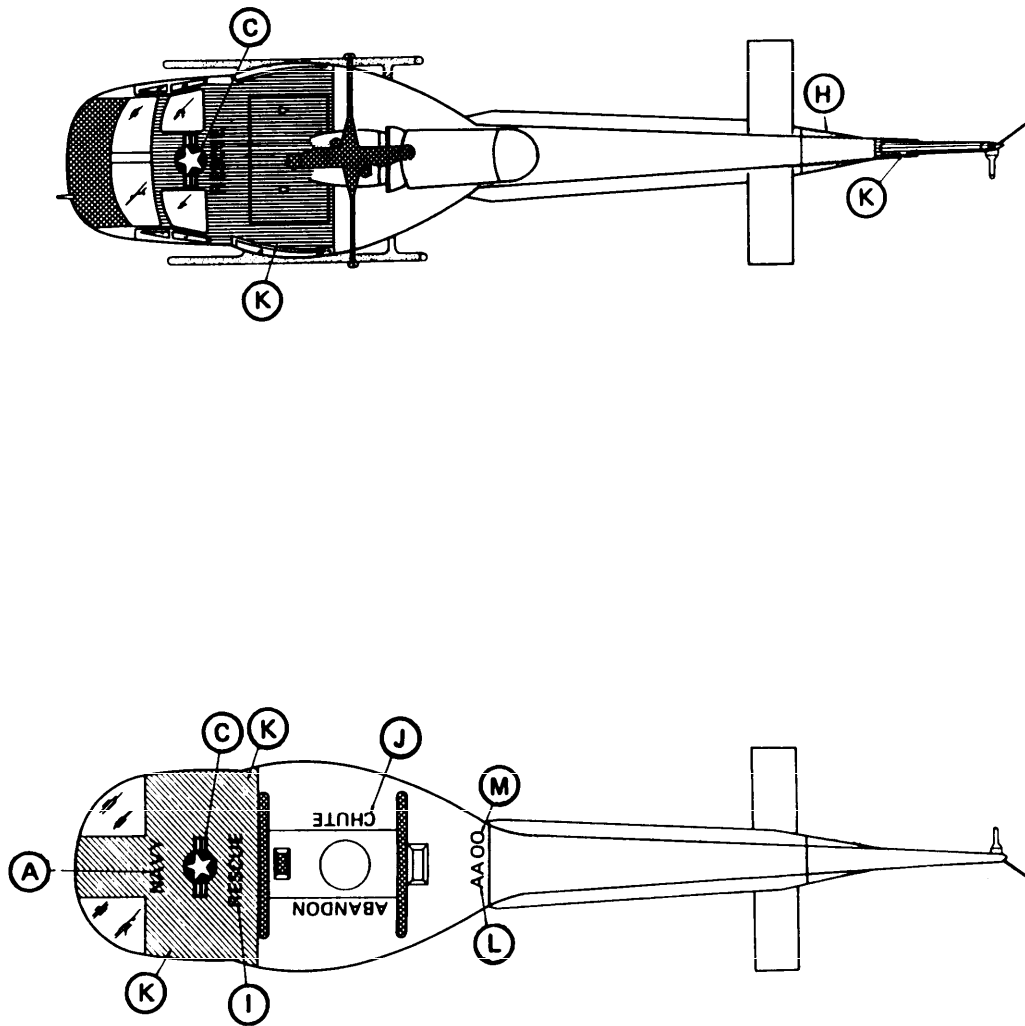
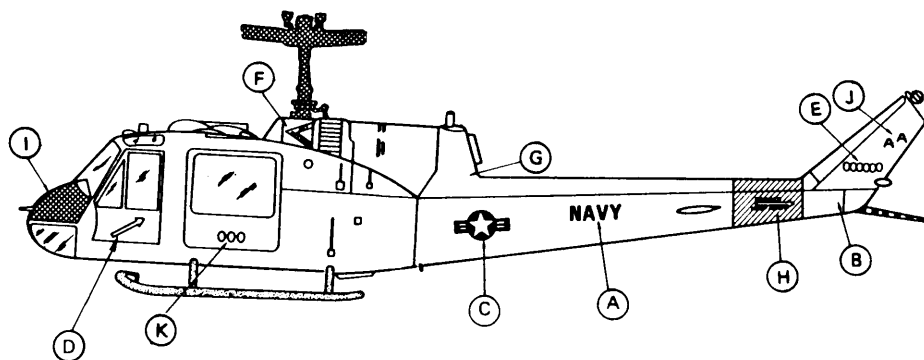


FIGURE C-21. UH-1E aircraft marking (SAR) - Continued.

MIL-STD-2161A(AS)

1. MARKING	2. LOCATION	3. SIZE	4. COLOR NO/CODE
A. NAVY	Bottom & Sides Fuselage	10"	17925/17038
B. Model Designation, Acft BUNO	Tail Boom R.H. & L.H. Sides	2" 6"	17925
C. National Star	Center Fuselage Bottom Fuselage Top Fuselage	15" 15" 15"	17925/11136/15044
D. Rescue Arrow	Cockpit Door	24"	13538/17038
E. Call Numbers	Tail Boom	6"	17925
F. Intake Warning	Engine Inlet Nacelle	15"	17925/11136
G. Beware of Blast	Engine Exhaust Nacelle	8"	17925/11136
H. Tail Rotor Warning	Aft Fuselage	33"	13538/11136/17038
I. Antiglare	Fwd. Fuselage	N/A	37038
J. Unit Identifier	Bottom Aft Fuselage Tail Boom	10"	17925
K. Unit Aircraft Numbers	Both Doors & Nose Bottom Aft Fuselage	10"	17925

 16081
FIGURE C-22. UH-1E aircraft marking.

MIL-STD-2161A(AS)

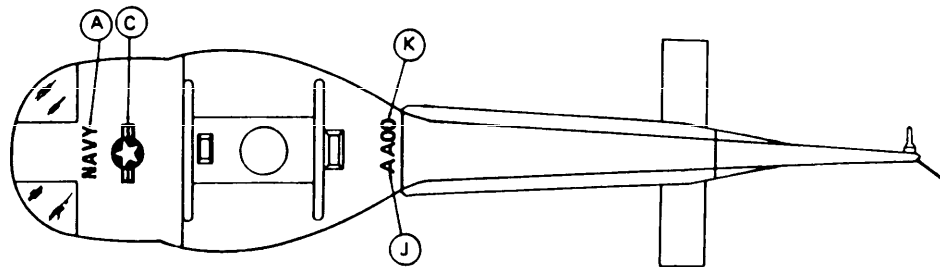
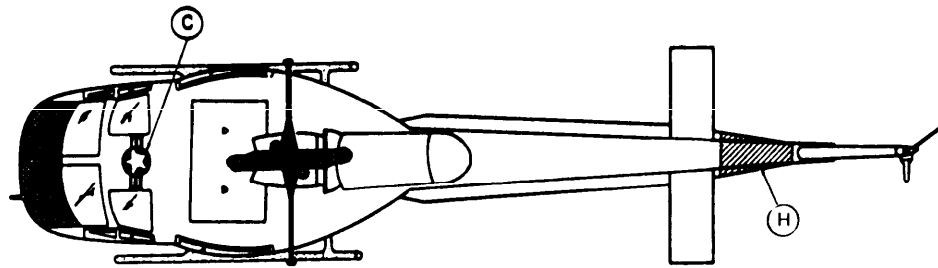
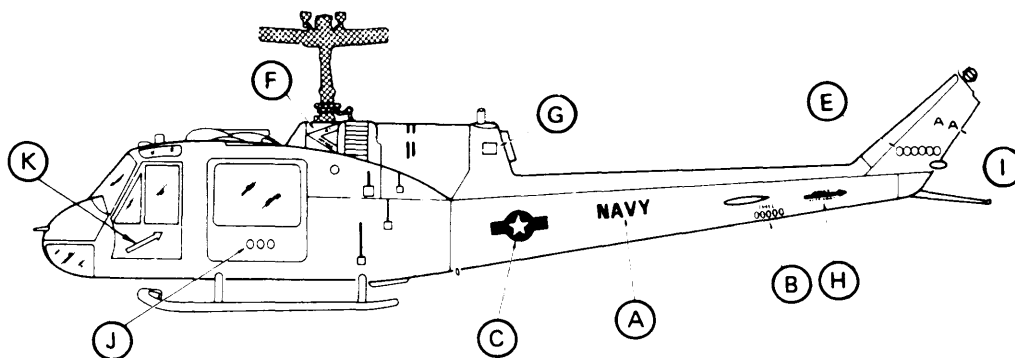


FIGURE C-22. UH-1E aircraft marking - Continued.

MIL-STD-2161A(AS)

1. MARKING	2. LOCATION	3. SIZE	4. COLOR NO/CODE
A. NAVY	Aft Fuselage	10"/10	37038
B. Model Designation, Acft BUNO	Aft Fuselage	2" 6"	37038
C. National Star	Aft Fuselage Top/Bottom	15"	37038
D. Walkway	Top of Fuselage	N/A	37038
E. Call Numbers	Tail Boom	6"	37038
F. Intake Warning	Fwd. Eng. Nacelle	15"	37038
G. Beware of Blast	Aft Eng. Nacelle	5"	37038
H. Tail Rotor Warning	Aft Fuselage	22"	37038
I. Unit Identifier	Tail Boom	8"	37038
J. Unit Aircraft Numbers	Door	8"	37038
K. Rescue Arrow	Cockpit Door	24"	13538/37038



34095

FIGURE C-23. HH-1K aircraft marking (land camouflage).

MIL-STD-2161A(AS)

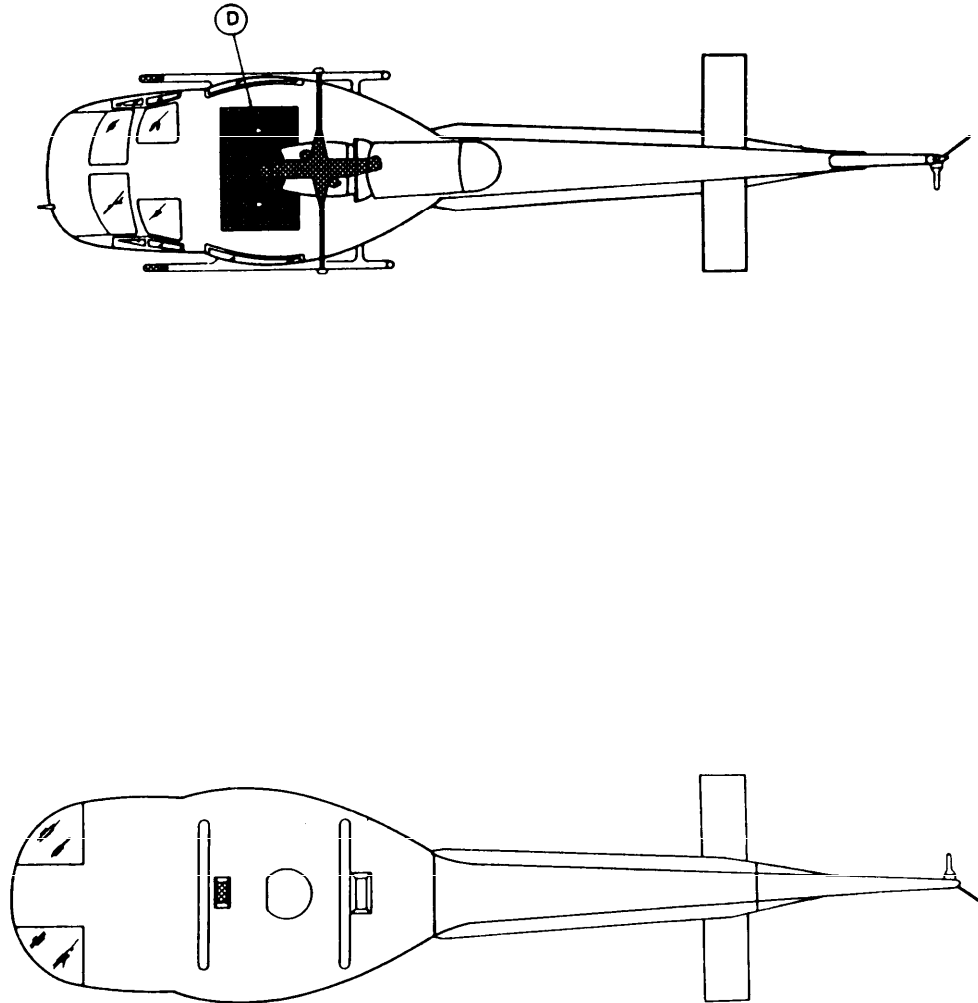


FIGURE C-23. HH-1K aircraft marking (land camouflage) - Continued.

MIL-STD-2161A(AS)

1. MARKING	2. LOCATION	3. SIZE	4. COLOR NO/CODE
A. NAVY	Tail Boom/ Bottom Fuselage	10"	17925
B. Model Designation, Acft BUONO	Side Tail Boom	2" 6"	17925
C. National Star	Aft Fuselage Top Fuselage Bottom Fuselage	15" 15" 15"	17925/11136/15044
D. Rescue Arrow	Fwd. Cockpit Door	24"	13538/37038
E. Intake Warning	Forward Intake	15"	11136/17925
F. Beware of Blast	Engine Exhaust Nacelle	5"	11136/17925
G. Tail Rotor Warning	Tail Boom	33"	13538/31136/17038
H. Antiglare	Fwd. Fuselage	N/A	37038
I. Walkway	Top Fwd. Fuselage	N/A	37038
J. Unit Aircraft Numbers	Mid Fuselage Bottom Fuselage	10"	17925
K. Unit Identifier	Tail Boom Bottom Fuselage	10"	17925

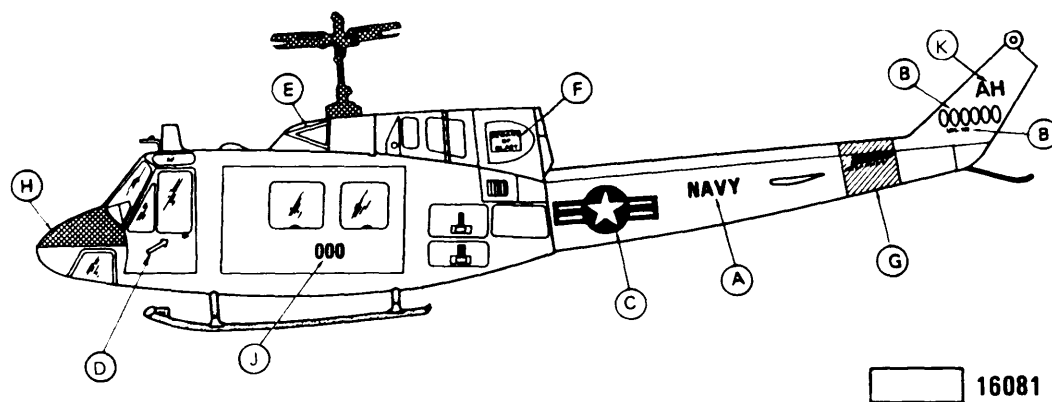


FIGURE C-24. UH-1N aircraft marking.

MIL-STD-2161A(AS)

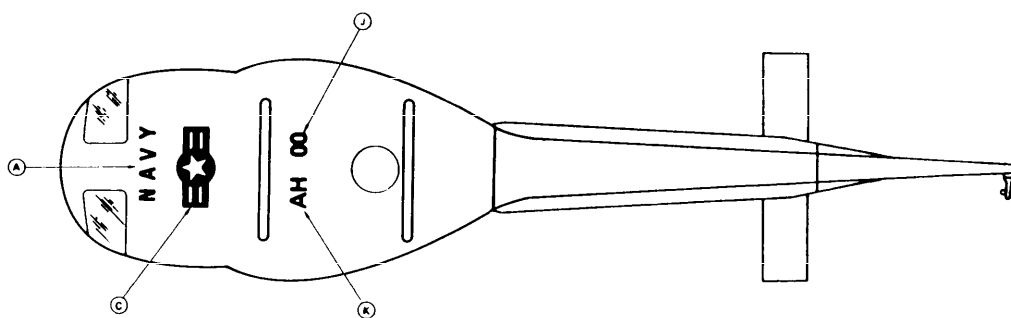
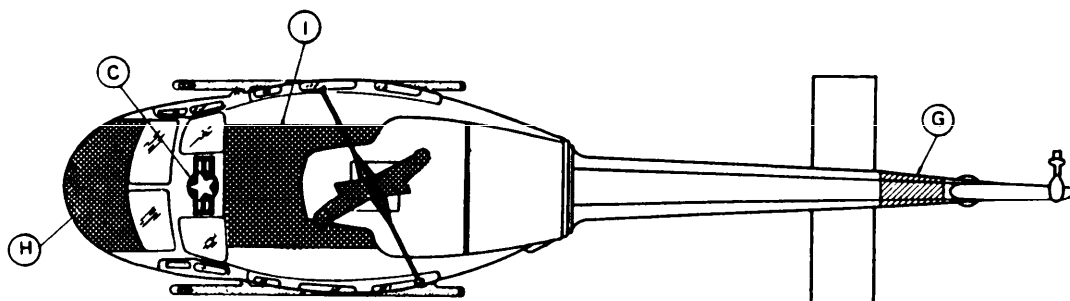
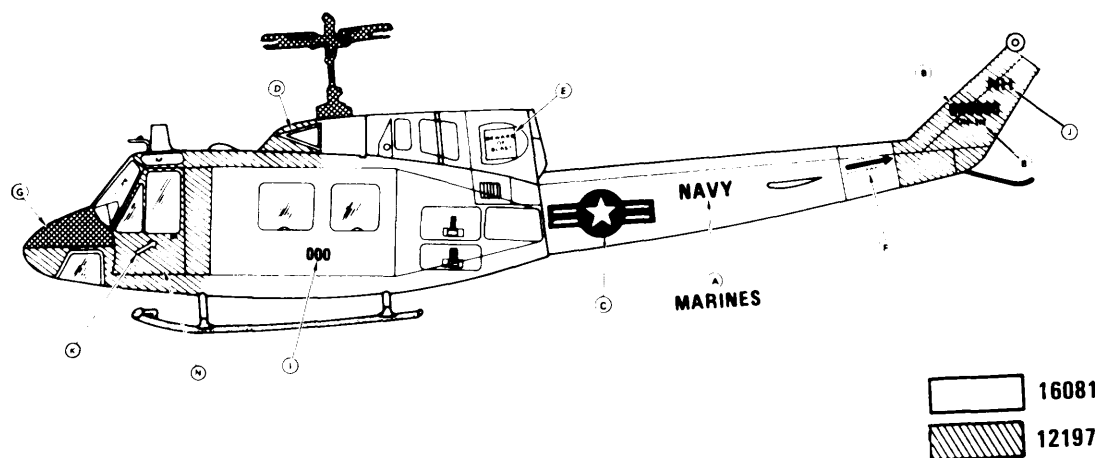


FIGURE C-24. UH-1N aircraft marking - Continued.

MIL-STD-2161A(AS)

1. MARKING	2. LOCATION	3. SIZE	4. COLOR NO/CODE
A. NAVY/MARINES	Tail Boom/ Bottom Fuselage	10"	17038
B. Model Designation, Acft BUONO	Side Tail Boom	2" 6"	17038
C. National Star	Aft Fuselage Top Fuselage Bottom Fuselage	15" 15" 15"	17925/11136/15044
D. Intake Warning	Forward Intake	15"	11136/17925
E. Beware of Blast	Engine Exhaust Nacelle	5"	11136/17925
F. Tail Rotor Warning	Tail Boom	33"	13538/31136/17038
G. Antiglare	Fwd. Fuselage	N/A	37038
H. Walkway	Top Fuselage	N/A	37038
I. Unit Aircraft Numbers	Mid Fuselage Bottom Fuselage	10"	17038
J. Unit Identifier	Tail Boom Bottom Fuselage	10"	17038
K. Rescue Arrow	Fwd. Cockpit Door	24"	13538/17925
L. Rescue	Bottom Aft Fuselage Top Fwd. Fuselage	10"	17038
M. Abandon Chute	Bottom Fuselage	10"	17038
N. Conspicuity Markings	Per Drawing	N/A	12197

FIGURE C-25. UH-1N aircraft marking (non-combat SAR).

MIL-STD-2161A(AS)

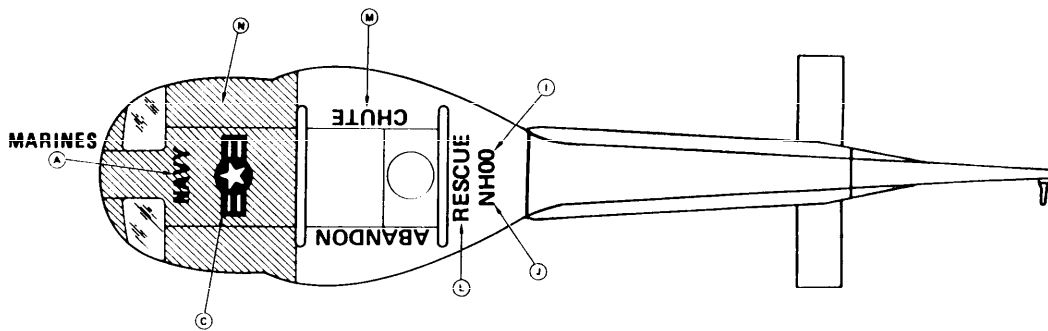
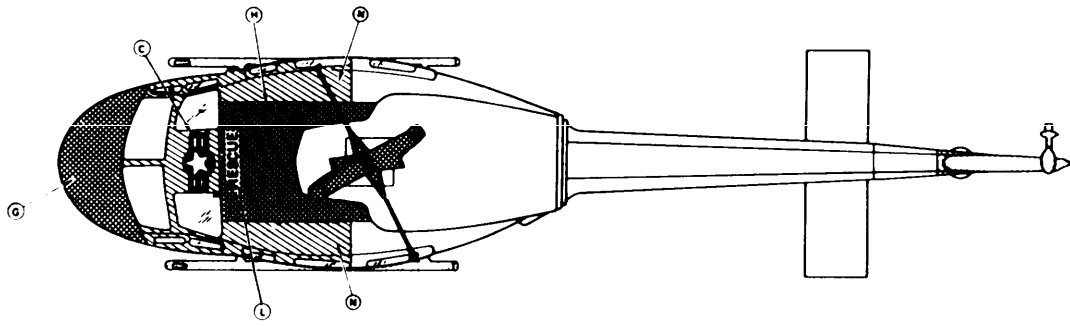
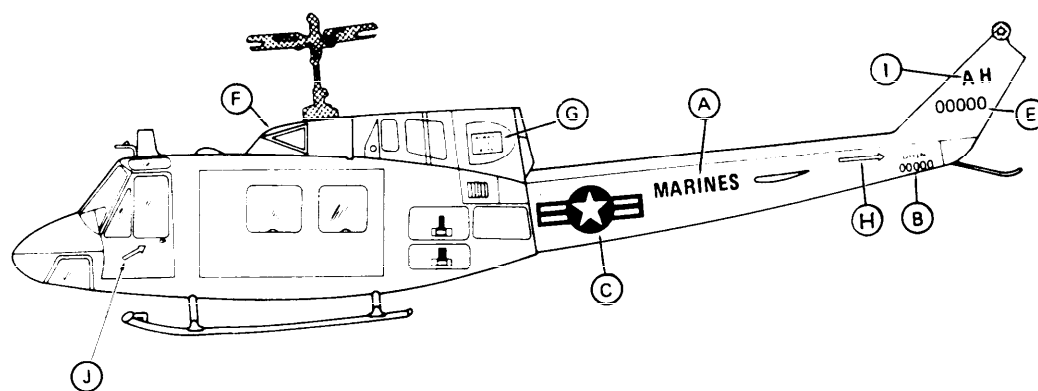


FIGURE C-25. UH-1N aircraft marking (non-combat SAR) - Continued.

MIL-STD-2161A(AS)

1. MARKING	2. LOCATION	3. SIZE	4. COLOR NO/CODE
A. MARINES	Tail Boom/ Bottom Fuselage	10"	IAW Para 5.2.3.2
B. Model Designation, Acft BUNO	Side Tail Boom	2" 6"	IAW Para 5.2.3.2
C. National Star	Aft Fuselage Top Fuselage Bottom Fuselage	15" 15" 15"	IAW Para 5.2.3.2
D. Walkway	Top Fwd. Fuselage	N/A	35237
E. Call Numbers	Aft Tail Boom	12"	IAW Para 5.2.3.2
F. Intake Warning	Forward Intake	15"	IAW Para 5.2.3.2
G. Beware of Blast	Engine Exhaust Nacelle	5"	IAW Para 5.2.3.2
H. Tail Rotor Warning	Tail Boom	33"	IAW Para 5.2.3.2
I. Unit Identifier	Tail Boom Bottom Fuselage	10"	IAW Para 5.2.3.2
J. Rescue Arrow	Fwd. Cockpit Door	24"	IAW Para 5.2.3.2

FIGURE C-26. UH-1N aircraft marking (tactical).

MIL-STD-2161A(AS)

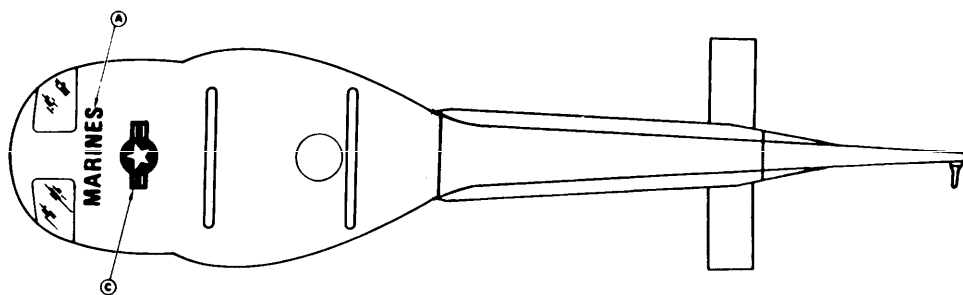
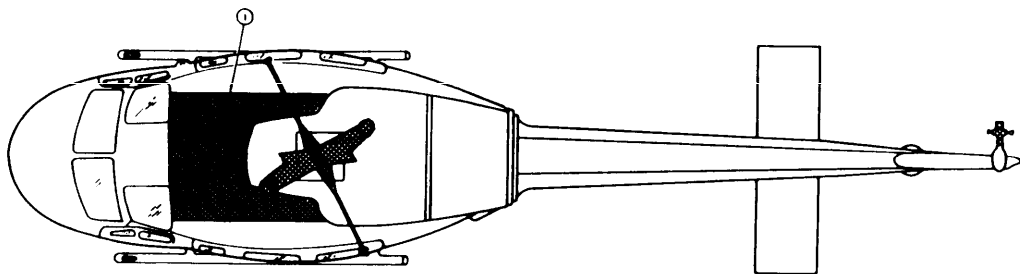


FIGURE C-26. UH-1N aircraft marking (tactical) - Continued.

MIL-STD-2161A(AS)

1. MARKING	2. LOCATION	3. SIZE	4. COLOR NO/CODE
A. NAVY	Bottom Fuselage Aft Fuselage	10" 10"	17038
B. Model Designation, Acraft BUNO	Tail Boom Tail Boom	2" 6"	17038
C. National Star	Aft Fuselage Top Fuselage Bottom Fuselage	15" 15" 15"	17925/11136/15044
D. Intake Warning	Engine Inlet Nacelle	15"	11136/17925
E. Beware of Blast	Aft Engine Exhaust Nacelle	5"	11136/17925
F. Tail Rotor Warning	Aft Fuselage	33"	17038
G. Antiglare	Fwd. Fuselage	N/A	37038
H. Walkway	Top Fuselage	N/A	32038
L. Conspicuity Markings	Per Drawing	N/A	12197
J. Unit Aircraft Numbers	Mid Fuselage Bottom Fuselage	10" 10"	17038 17038
K. Unit Identifier	Tail Boom Bottom Fuselage	10" 10"	17038
L. Rescue Arrow	Fwd. Cockpit Door	24"	13538/17925

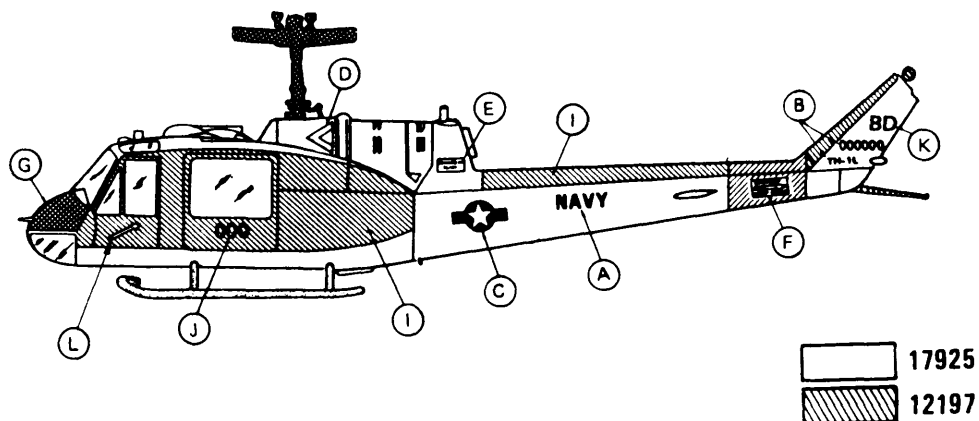


FIGURE C-27. TH-1L aircraft marking.

MIL-STD-2161A(AS)

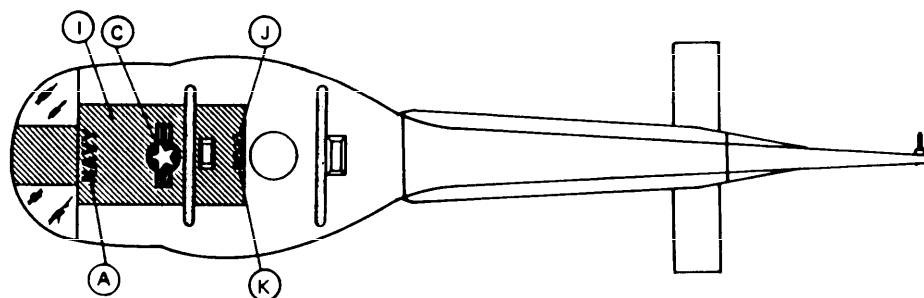
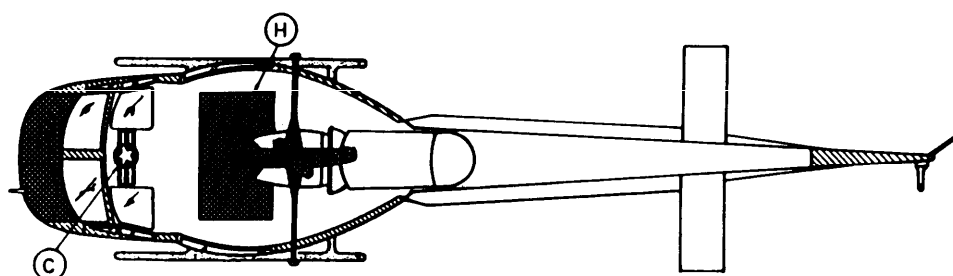


FIGURE C-27. TH-1L aircraft marking - Continued.

MIL-STD-2161A(AS)

1. MARKING	2. LOCATION	3. SIZE	4. COLOR NO/CODE
A. NAVY	Tail Boom	12"	35237
B. Model Designation, Acft BUNO	Side Tail Boom	2" 4"	35237
C. National Star	Aft Fuselage Top Fuselage Bottom Fuselage	12" 12" 12"	35237/36320 36320/35237 36320/36495
D. Intake Warning	Forward Intake	15"	36320/35237
E. Beware of Blast	Below Exhaust Exit	5"	36320/35237
F. Tail Rotor Warning	Tail Boom	33"	35237
G. Antiglare	Nose Fwd. of Canopy	N/A	35237
H. Walkway	Top Fuselage	N/A	36320
I. Call Numbers	Aft Fuselage	12"	35237
J. Unit Aircraft Numbers	Fwd. Fuselage Tail Boom Mid	10"	35237
K. Unit Identifier	Tail Boom	10"	35237
L. Rescue Arrow	Pilot Cockpit Door Copilot Cockpit Door	24" 18"	36320/35237
M. Sonobuoy Launch Door Marking	Center Left Fuselage	2" 2" 1"	35237
N. Main Rotor Blades		N/A	35237
O. Tail Rotor Blades		N/A	36320

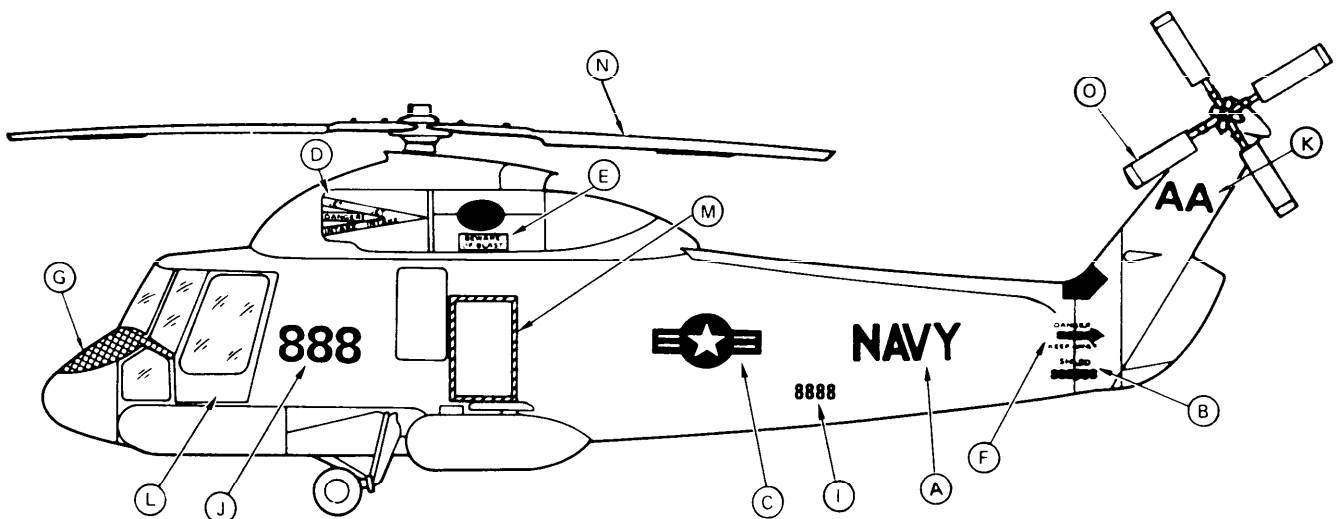


FIGURE C-28. SH-2 aircraft marking (tactical).

MIL-STD-2161A(AS)

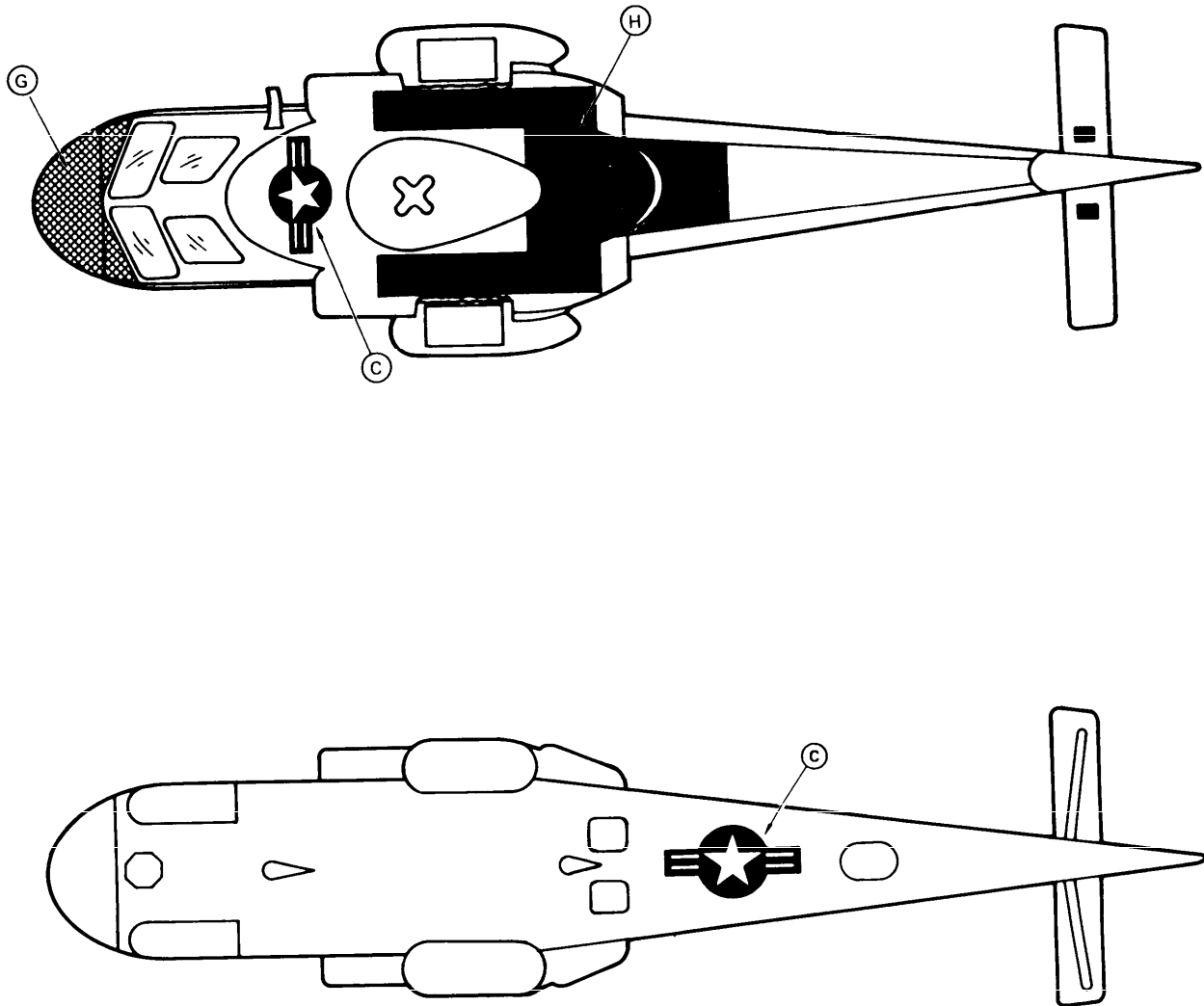


FIGURE C-28. SH-2 aircraft marking (tactical) - Continued.

MIL-STD-2161A(AS)

1. MARKING	2. LOCATION	3. SIZE		4. COLOR NO/CODE
A. NAVY	Lower Fuselage	12"	12"	37038/17925*
	Aft Fuselage	24"	24"	
B. Model Designation, Acft BUONO	Aft Fuselage	2"		37038/17925*
		4"		
C. National Star	Upper Tail Boom		25"	
	Lower Fuselage	12"	30"	37038/17925*
	Center Fuselage		30"	
D. Unit Aircraft Number	Fwd. Fuselage	12"		37038/17925*
E. Call Numbers	Lower Aft Fuselage	12"		37038/17038*
F. Intake Warning	Fwd. Engine Nacelle	16"		37038
				11136/17925*
G. Beware of Blast	Aft Engine Nacelle	22"		37038
				11136/17925*
H. Tail Rotor Warning	Aft Fuselage	29"		37038
				11136/17925*
I. Anti glare	Nose Fwd. of Cockpit	N/A		37038
J. Unit Identifier	Tail Boom	10"		37038/17925*
K. Tip Marking	Horizontal Stabilizer	6"		37038/11136*
L. Rescue Arrow	Fwd. and Center Fuselage	24"		37038
				17038/13538*
M. Walkway	Top Fuselage	N/A		37038/17038*
N. Conspicuity Marking	Per Dwg (UH-3A Only)			12197*
O. Abandon Chute/Rescue	Bottom of Fuselage (UH-3A Only)			17038*
P. Main Rotor Blades		N/A		35237
Q. Tail Rotor Blades		N/A		36320

*UH-3A

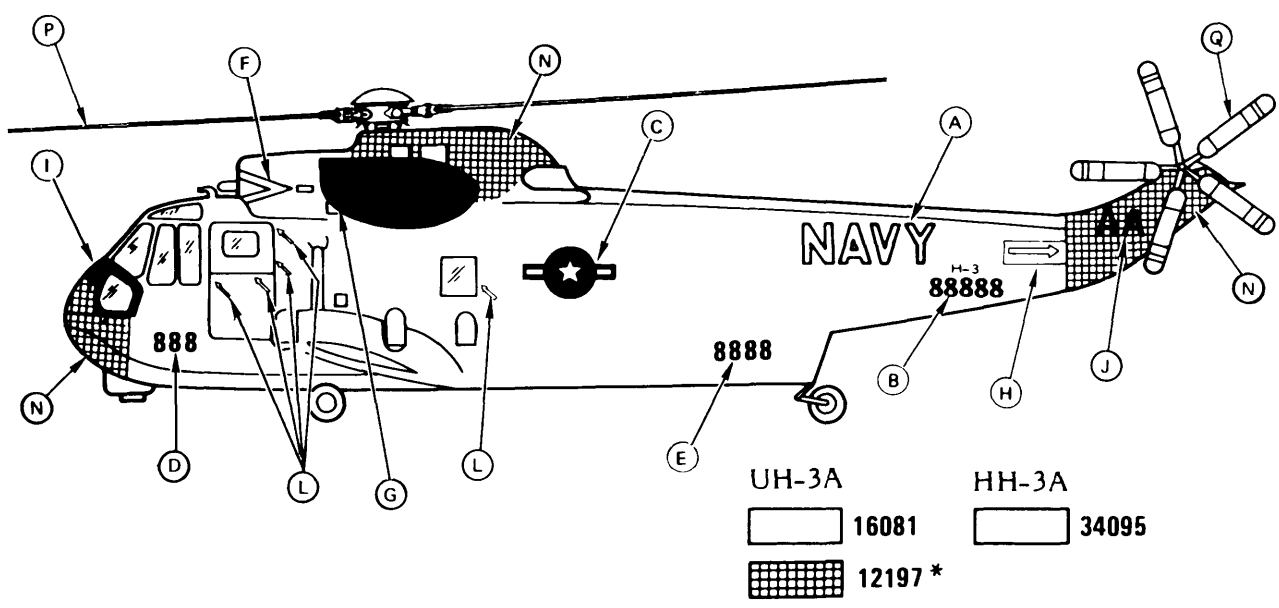


FIGURE C-29. HH-3A/UH-3A aircraft marking.

MIL-STD-2161A(AS)

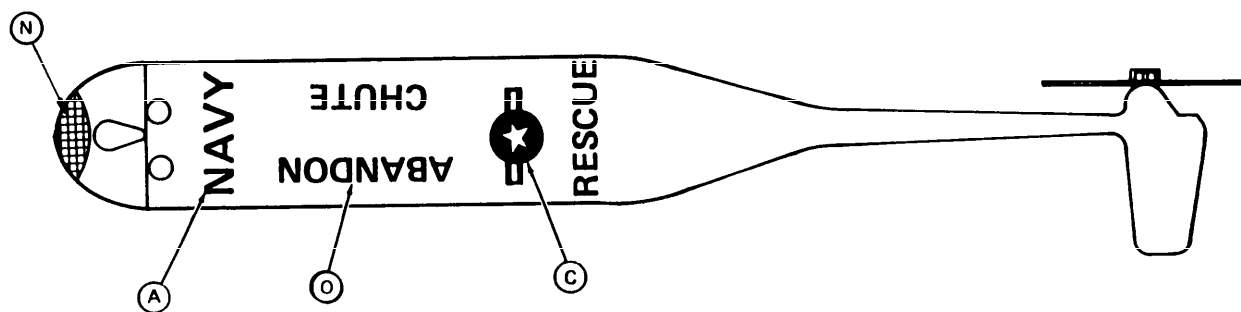
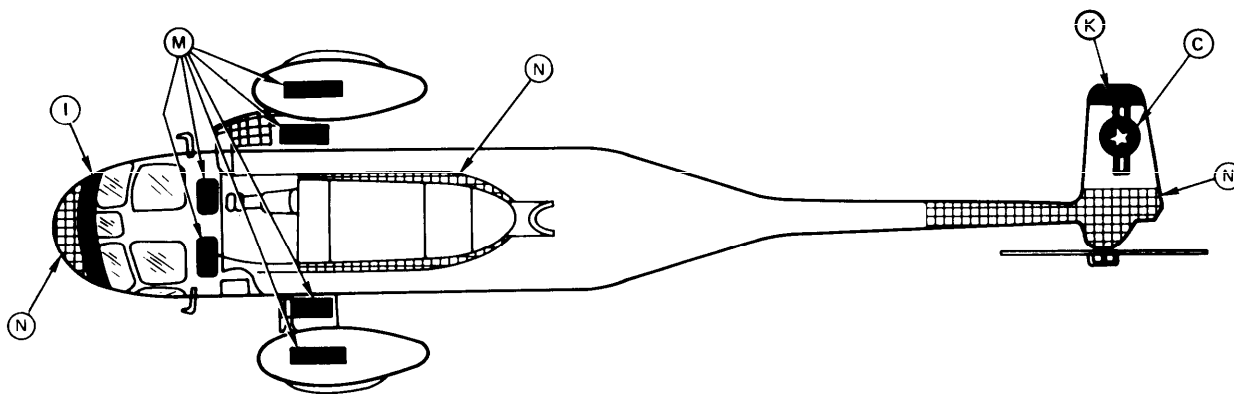


FIGURE C-29. HH-3A/UH-3A aircraft marking - Continued.

MIL-STD-2161A(AS)

1. MARKING	2. LOCATION	3. SIZE	4. COLOR NO/CODE
A. NAVY	Lower Fuselage Aft Fuselage	12" 24"	17038
B. Model Designation, Acft BUNO	Aft Fuselage	2" 4"	17038
C. National Star	Upper Tail Boom Lower Fuselage Center Fuselage	25" 30" 30"	17925/11136/15044
D. Unit Identifier	Tail Boom	10"	17038
E. Call Numbers	Lower Aft Fuselage	12"	17038
F. Intake Warning	Fwd. Engine Nacelle	16"	17925/11136
G. Beware of Blast	Aft Engine Nacelle	22"	17925/11136
H. Tail Rotor Warning	Aft Fuselage	35"	11136/17038
I. Antiglare	Nose	N/A	37038
J. Walkway	Top Center Fuselage	N/A	36231
K. Abandon Chute/Rescue	Bottom of Fuselage	12"	17038
L. Conspicuity Marking	Per Drawing	(SAR Only)	12197
M. Red Tip	Horizontal Stabilizer	6"	11136
N. Unit Aircraft Numbers	Fwd. Fuselage	12"	17038
O. Rescue Arrows	Fwd. & Center Fuselage L.H. & R.H. Sides	24"	17038/13538
P. Main Rotor Blades		N/A	35237
Q. Tail Rotor Blades		N/A	36320

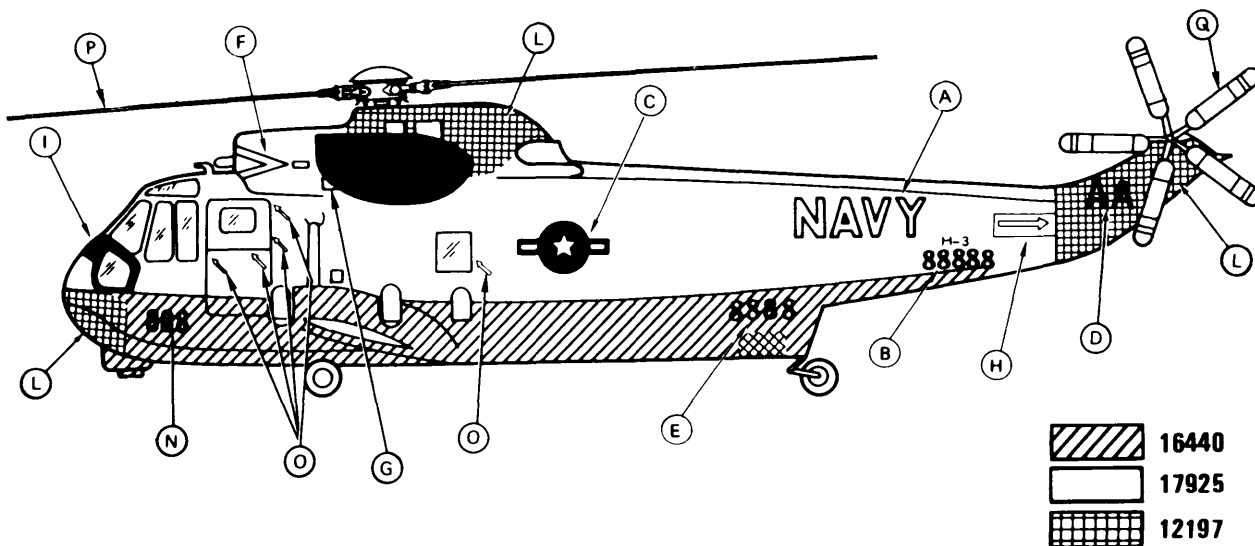


FIGURE C-30. SH-3G aircraft marking (high visibility) (SAR).

MIL-STD-2161A(AS)

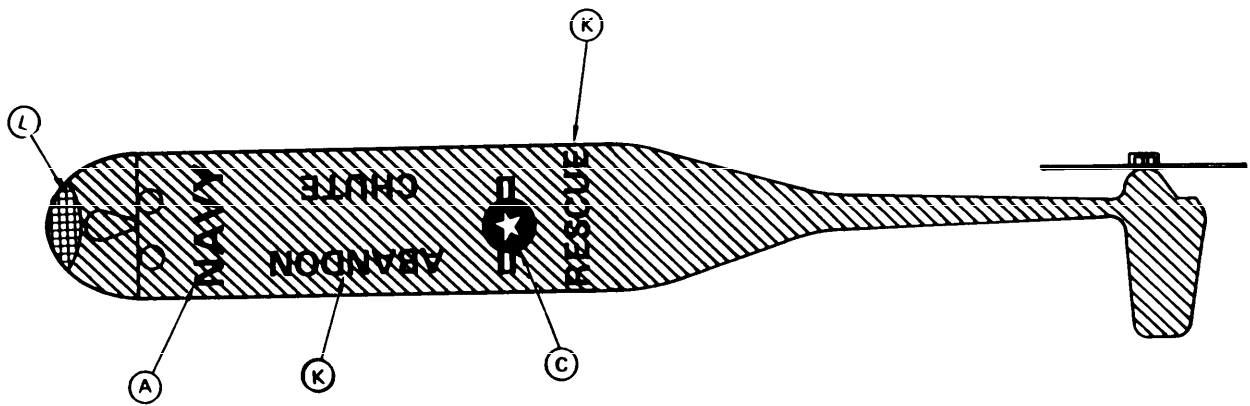
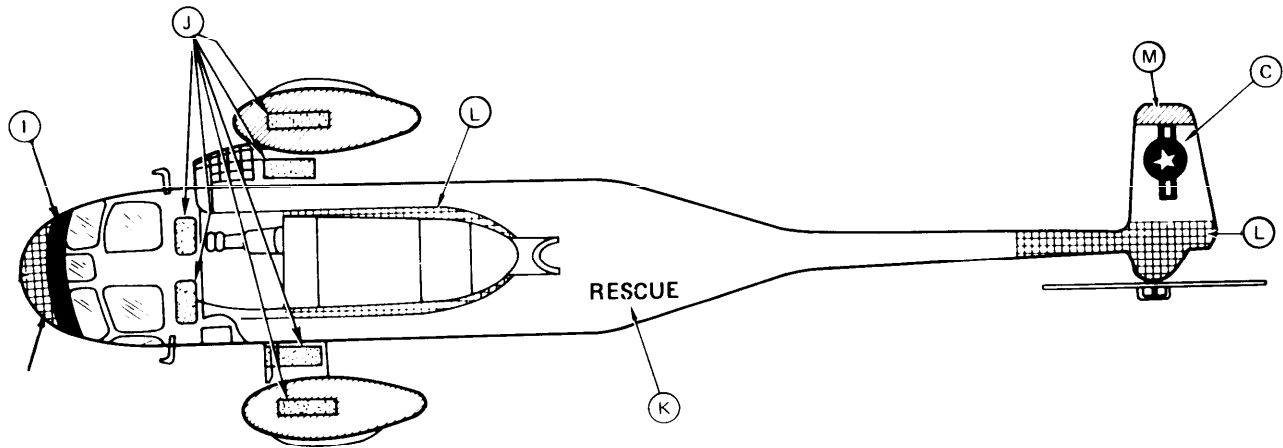


FIGURE C-30. SH-3G aircraft marking (high visibility) (SAR) - Continued.

MIL-STD-2161A(AS)

1. MARKING	2. LOCATION	3. SIZE	4. COLOR NO/CODE
A. NAVY	Aft Fuselage & Bottom Fuselage L.H. Side	12" 12"	17925
MARINES	Aft Fuselage & Bottom Fuselage L.H. Side L.H. Side	10" 12"	17925
B. Model Designation, Acft BUNO	Aft of Branch of Service Markings	2" 4"	17925
C. National Star	Center Lower Fuselage Top Center Fuselage Bottom Lower Fwd. Fuselage	20"	15044/11136/17925
D. Call Numbers	Aft Pylon	9"	17038
E. Rescue	Upper Fuselage Lower Fuselage	12" 12"	17038
F. Abandon Chute	Lower Fuselage	12"	17925
G. Walkway	Top of Fuselage and Top of Fuselage Gear Housings	N/A	37038
H. Conspicuity Markings	Per Drawing	N/A	12197
I. Squadron Designation		6"	17925
J. Unit Aircraft Numbers	Upper Center Fuselage Nose Electronics Compartment Door	20"	17925
K. Unit Identifier	Top of Aft Pylon	24"	17925
L. Rescue Arrows	Fwd. and Center of Fuselage Rescue Hatch (if installed)	18"	13539/17038

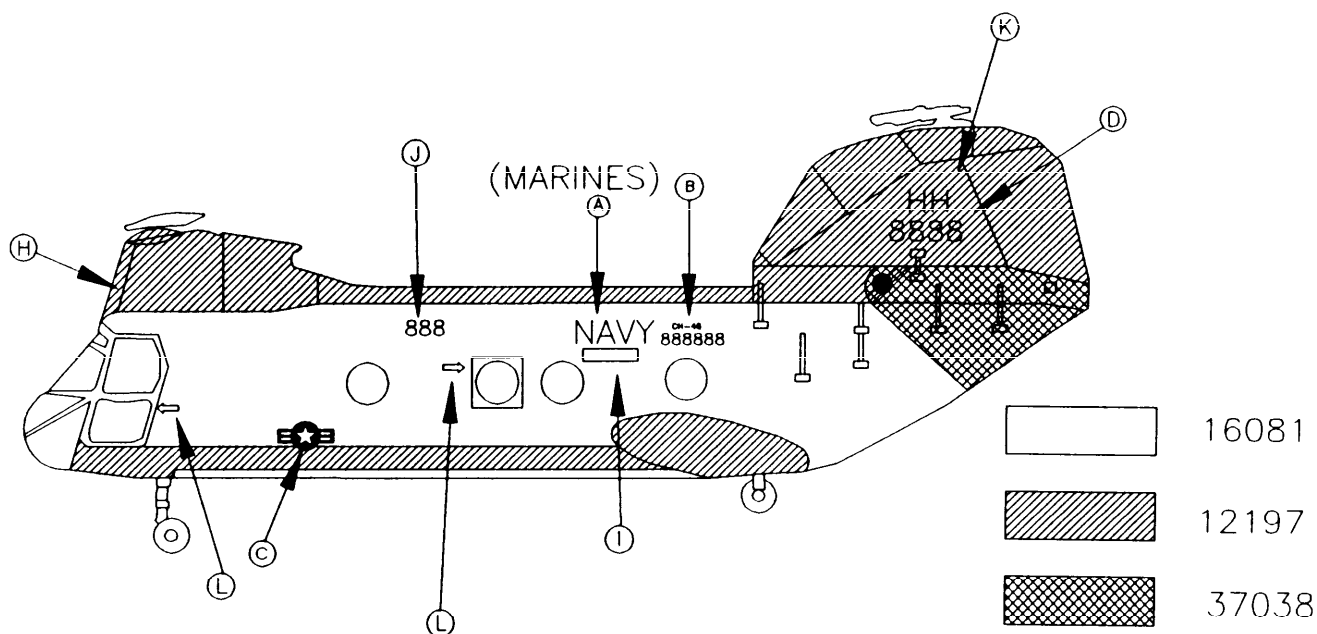


FIGURE C-31. HH-46D aircraft marking (high visibility) (SAR).

MIL-STD-2161A(AS)

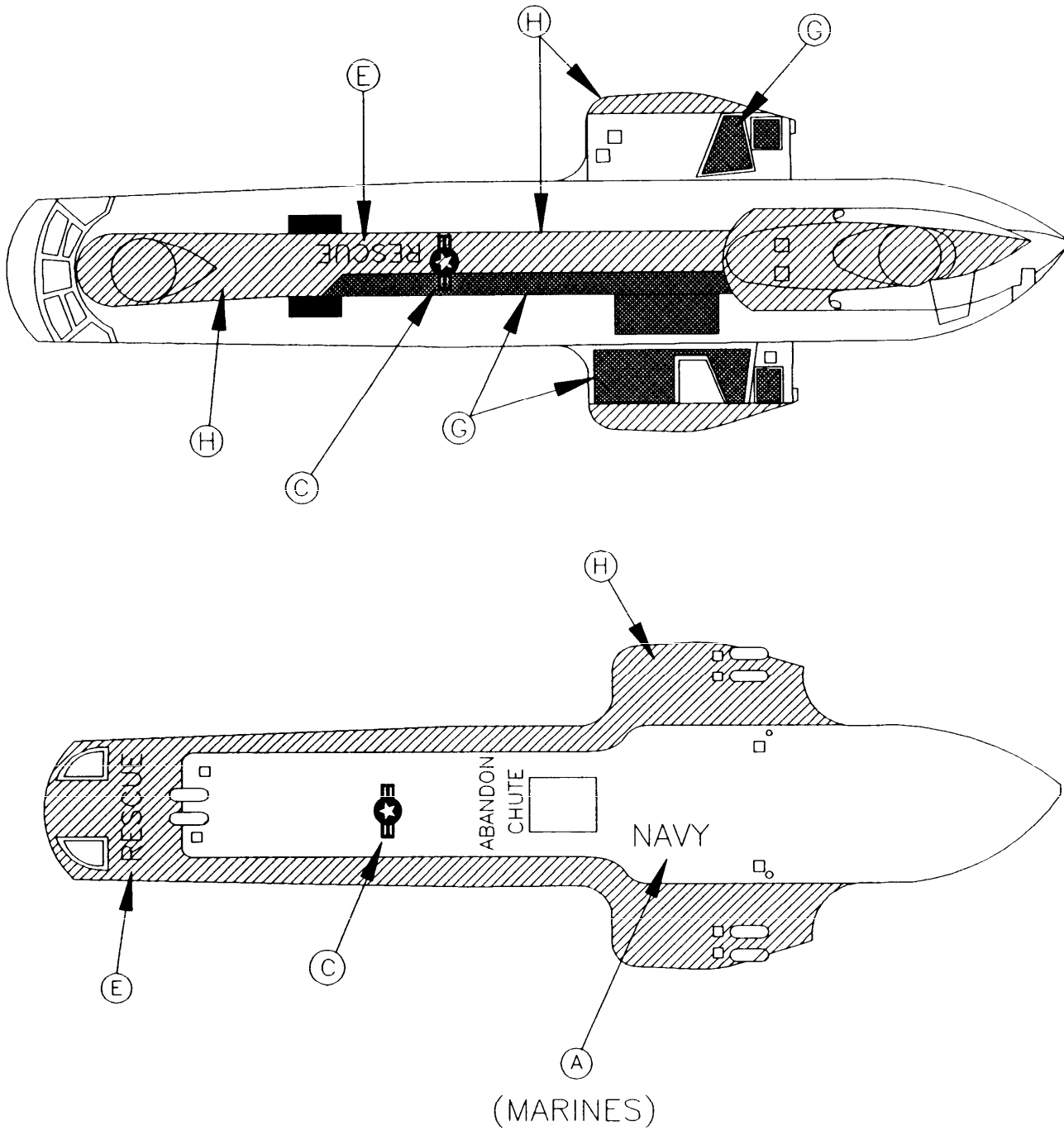


FIGURE C-31. HH-46D aircraft marking (high visibility) (SAR) - Continued.

MIL-STD-2161A(AS)

1. MARKING	2. LOCATION	3. SIZE	4. COLOR NO/CODE
A. MARINES	Aft Fuselage & Bottom Fuselage L.H. Side	12"	IAW Para 5.2.3.2
B. Model Designation, Acft BUNO	Aft of MARINE Markings	2" 4"	IAW Para 5.2.3.2
C. National Star	Center Lower Fuselage Top Center Fuselage Bottom Lower Fwd. Fuselage	30"	IAW Para 5.2.3.2
D. Walkway	Top of Fuselage Top of Stubwings	N/A	35237
E. Call Numbers	Aft Pylon	12"	IAW Para 5.2.3.2
F. Unit Aircraft Numbers	Upper Center Fuselage Nose Electronic Compartment Door	20"	IAW Para 5.2.3.2
G. Unit Identifier	Top of Aft Pylon	24"	IAW Para 5.2.3.2
H. Squadron Designation	Aft Fuselage	6"	IAW Para 5.2.3.2
I. Rescue Arrow	Fwd. & Center Fuselage	24" 31"	IAW Para 5.2.3.2

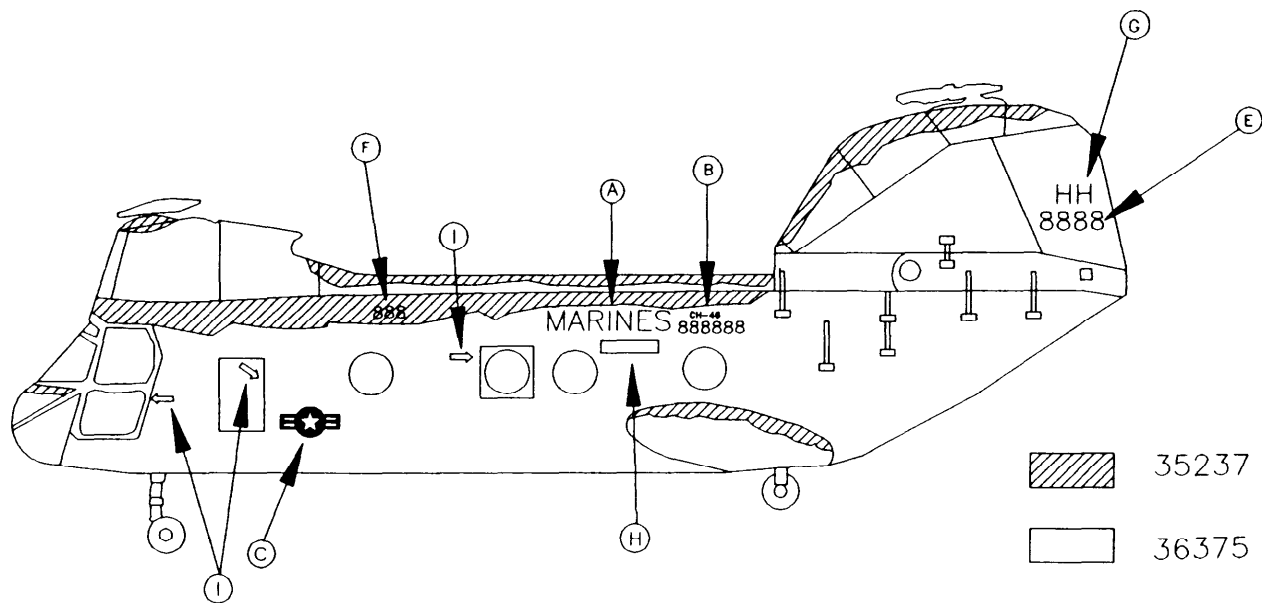


FIGURE C-32. CH-46E aircraft marking (tactical).

MIL-STD-2161A(AS)

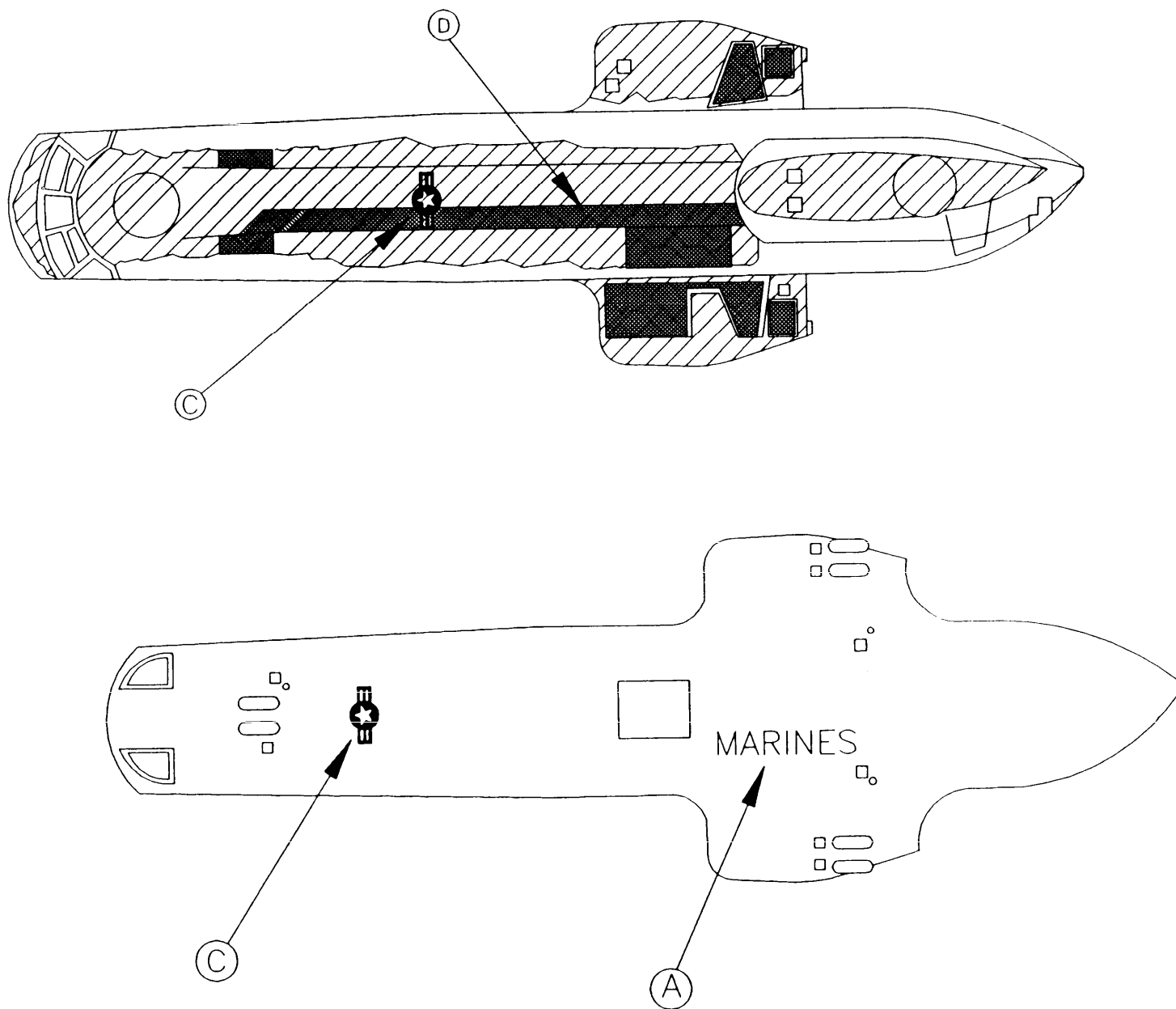


FIGURE C-32. CH-46E aircraft marking (tactical) - Continued.

MIL-STD-2161A(AS)

1. MARKING	2. LOCATION	3. SIZE	4. COLOR NO/CODE
A. NAVY	Aft Fuselage & Bottom Fuselage (L.H. Side) L.H. Side	12"	17925
B. Model Designation, Acft BUNO	Aft of NAVY Markings	2" 4"	17925
C. National Star	Center Lower Fuselage Top Center Fuselage Bottom Lower Fwd. Fuselage	30"	15044/11136/17925
D. Walkway	Top of Fuselage Top of Landing Gear Housings	N/A	37038
E. Call Numbers	Aft Pylon	12"	17038
F. Unit Aircraft Numbers	Upper Center Fuselage Nose Electronic Compartment Door	20"	17925
G. Unit Identifier	Top of Aft Pylon	24"	17925
H. Squadron Designation	Aft Fuselage	6"	17925
I. Rescue Arrow	Fwd. & Center Fuselage	24" 31"	37038

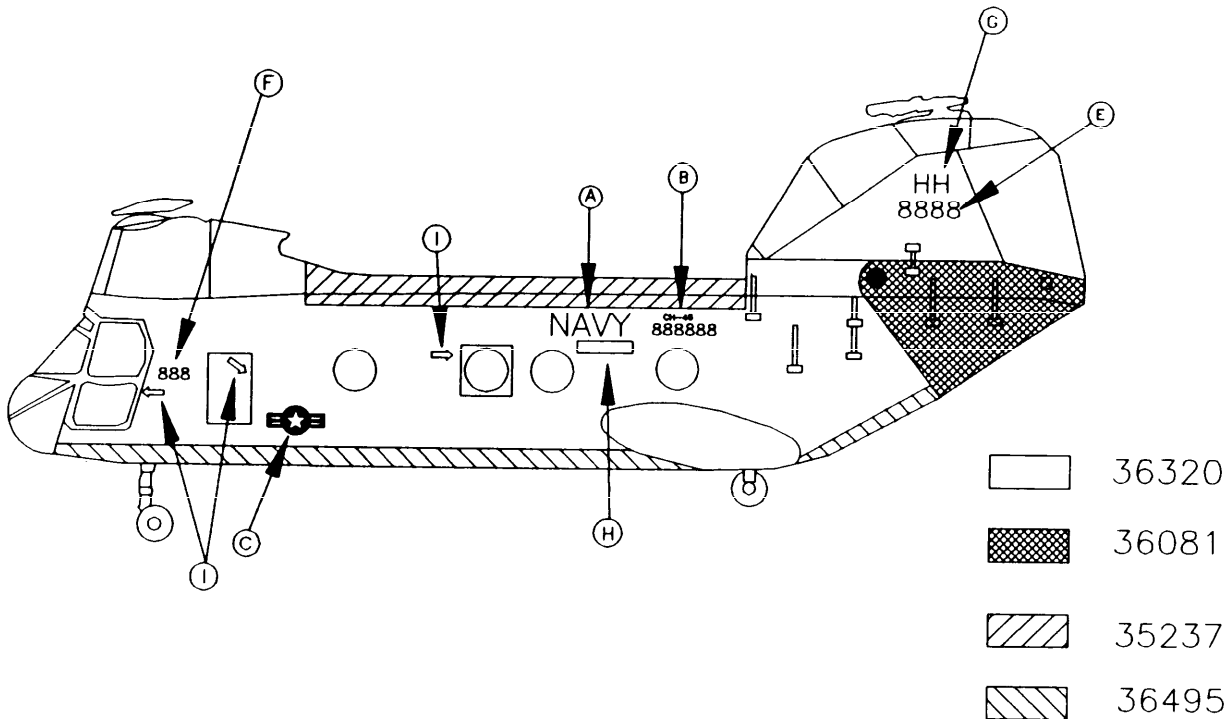


FIGURE C-33. UH-6A/D aircraft marking.

MIL-STD-2161A(AS)

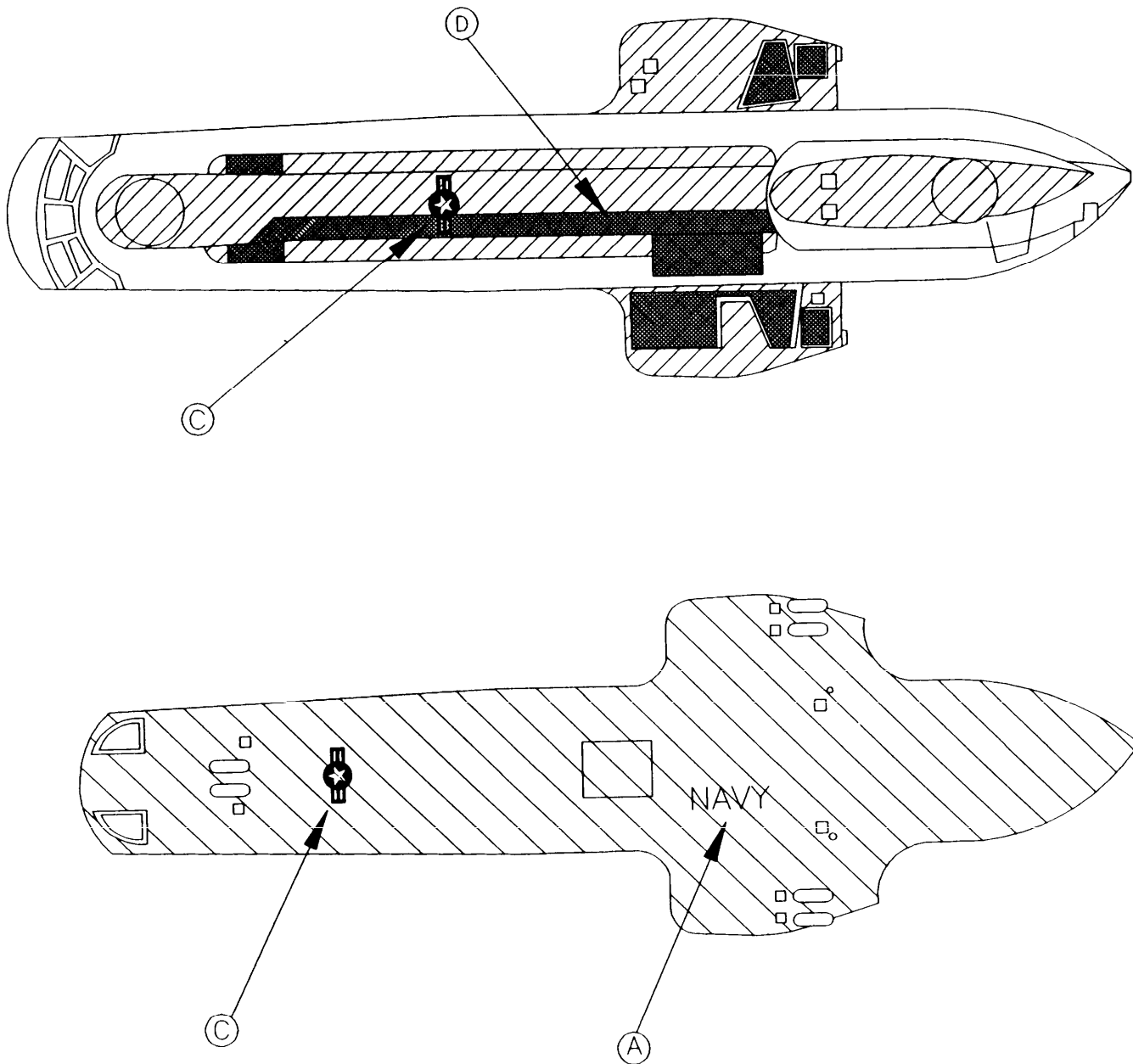
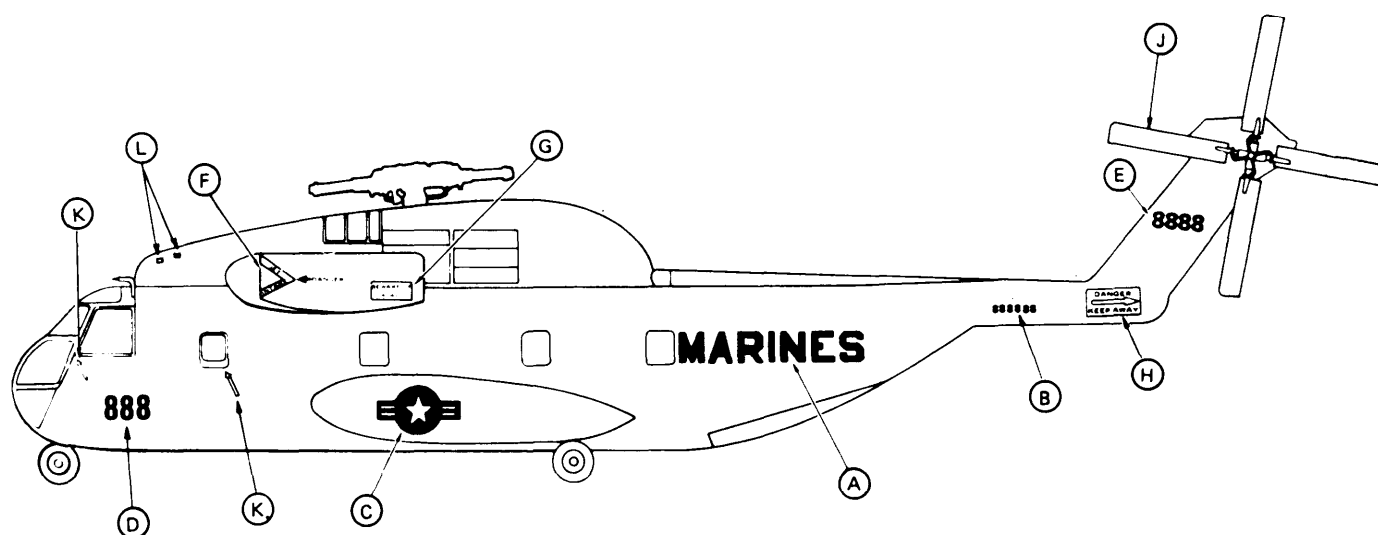


FIGURE C-33. UH-46A/D aircraft marking - Continued.

MIL-STD-2161A(AS)

1. MARKING	2. LOCATION	3. SIZE	4. COLOR NO/CODE
A. MARINES	Aft Fuselage	20"	IAW Para 5.2.3.1
B. Model Designation, Acft BUONO	Aft Fuselage	2" 4"	IAW Para 5.2.3.1
C. National Star	Bottom Fuselage Aft Fuselage Horizontal Stabilizer	20"	IAW Para 5.2.3.1
D. Unit Identification Number	Fwd. Lower Fuselage	30"	IAW Para 5.2.3.1
E. Call Numbers	Aft Tail Rotor Boom	8"	IAW Para 5.2.3.1
F. Intake Warning	Fwd. Engine Nacelle	36"	IAW Para 5.2.3.1
G. Beware of Blast	Aft Engine Nacelle	10" x 20"	IAW Para 5.2.3.1
H. Tail Rotor Warning	Aft Tail Boom	24"	IAW Para 5.2.3.1
I. Walkway	Per Drawing	N/A	IAW Para 5.2.3.1
J. Tail Rotor Blades	N/A	N/A	IAW Para 5.2.3.1
K. Rescue Arrow	Fwd. Fuselage	24"	IAW Para 5.2.3.1
L. Keep Clear +EXHAUST+	Exhaust Ports Upper Fwd. Fuselage	1" Letters 1½" Arrows	IAW Para 5.2.3.1

FIGURE C-34. CH-53 aircraft marking (land camouflage).

MIL-STD-2161A(AS)

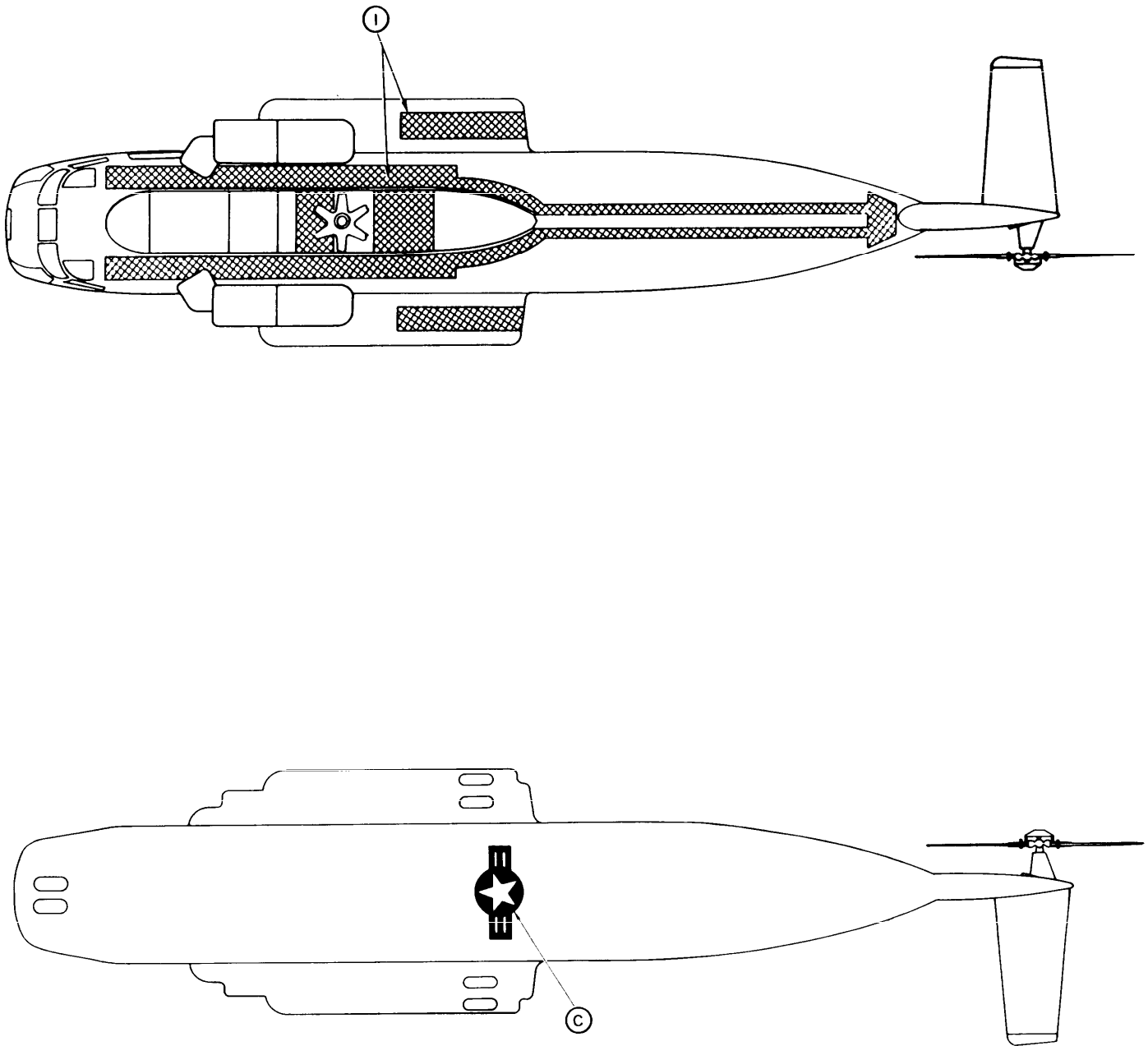


FIGURE C-34. CH-53 aircraft marking (land camouflage) - Continued.

MIL-STD-2161A(AS)

1. MARKING	2. LOCATION	3. SIZE	4. COLOR NO/CODE
A. NAVY	Aft Fuselage	24"	IAW Para 5.2.3.2
B. Model Designation, Acft BUNO	Aft Fuselage	2" 4"	IAW Para 5.2.3.2
C. National Star	Aft Fuselage Horizontal Stabilizer Bottom of Fuselage	25" 30"	IAW Para 5.2.3.2
D. Unit Identification Number	Fwd. Lower Fuselage	30"	IAW Para 5.2.3.2
E. Call Numbers	Tail Rotor Support	8"	IAW Para 5.2.3.2
F. Intake Warning	Fwd. Engine Nacelles	2" Letters 36" 3" Chevron	IAW Para 5.2.3.2
G. Beware of Blast		10"	IAW Para 5.2.3.2
H. Tail Rotor Warning	Aft Tail Boom	24"	IAW Para 5.2.3.2
I. Walkway	Per Drawing	N/A	35237
J. Keep Clear Exhaust	Upper Fwd. Fuselage Between Exhaust Ducts L.H. Side	5"	IAW Para 5.2.3.2
K. Rescue Arrow	Fwd. Fuselage	24"	IAW Para 5.2.3.2

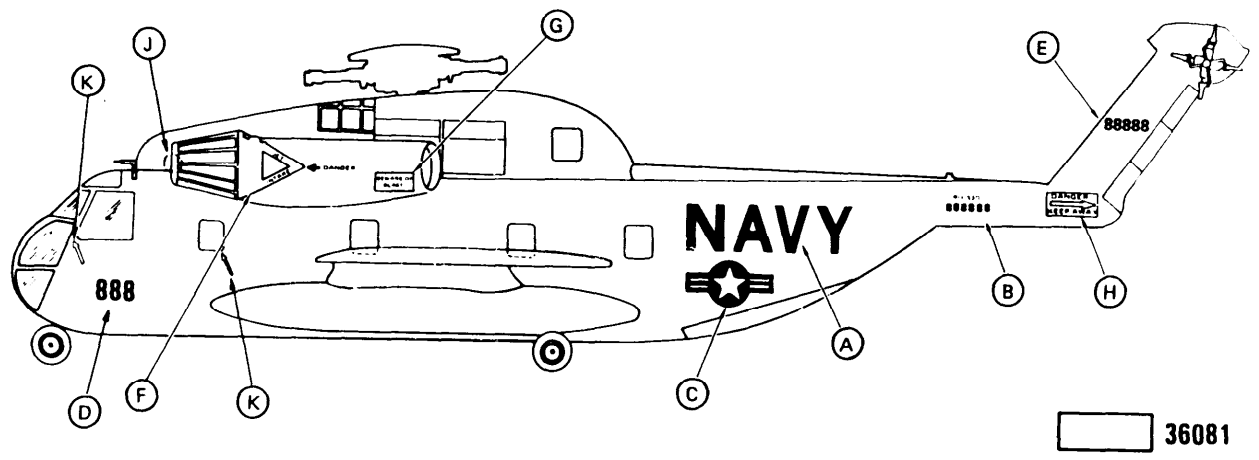


FIGURE C-35. CH-53D/RH-53D aircraft marking (tactical).

MIL-STD-2161A(AS)

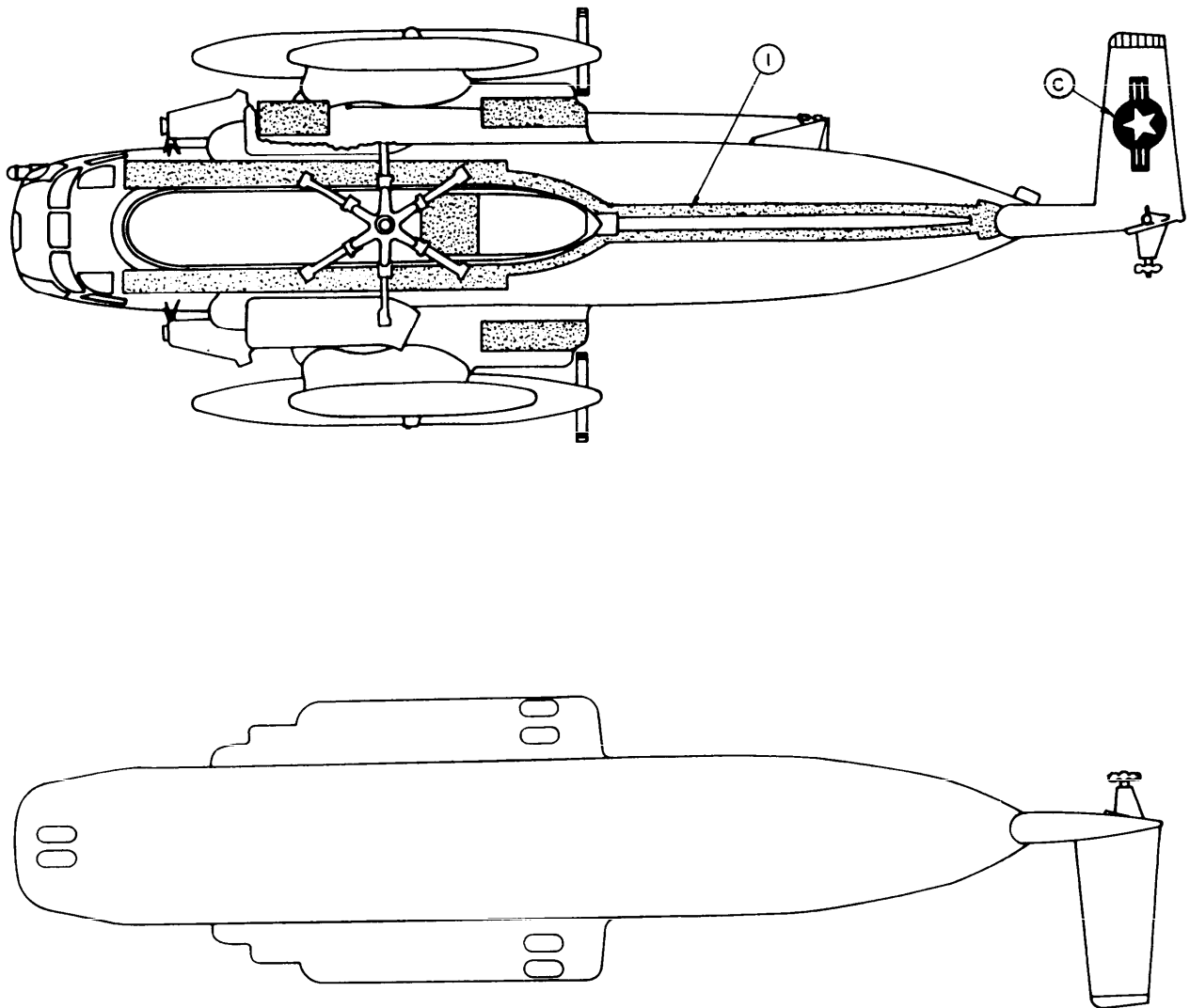
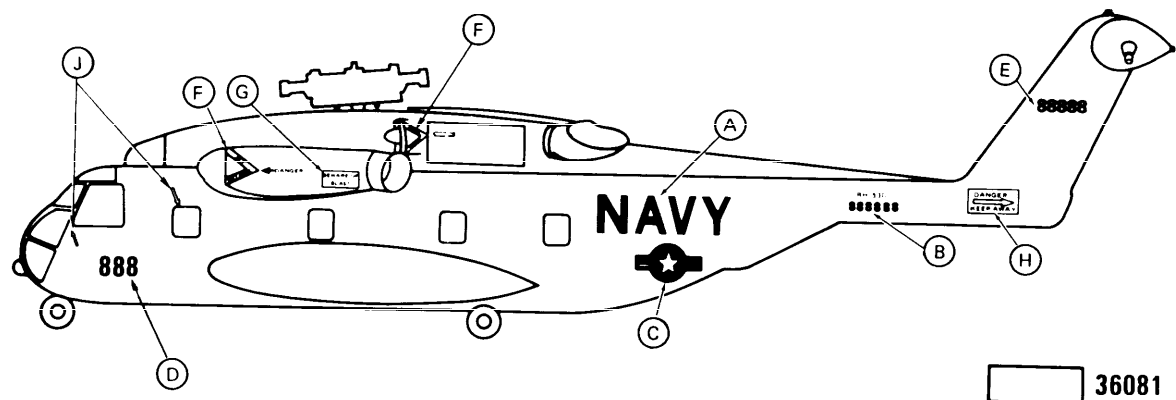


FIGURE C-35. CH-53D/RH-53D aircraft marking (tactical) - Continued.

MIL-STD-2161A(AS)

1. MARKING	2. LOCATION	3. SIZE	4. COLOR NO/CODE
A. NAVY	Aft Fuselage	24"	35237
B. Model Designation, Aft BUNO	Aft Fuselage	2" 4"	35237
C. National Star	Aft Fuselage Horizontal Stabilizer	25" 30"	35237
D. Unit Identification Numbers	Fwd. Lower Fuselage	30"	35237
E. Call Numbers	Upper Tail Boom	6"	35237
F. Intake Warning	Engine Intake Nacelles	16"	35237
G. Beware of Blast	Lower Aft Section L.H. & R.H. Engine Nacelles	2" Letters	35237
H. Tail Rotor Warning	Aft Tail Boom	24"	35237
I. Walkway	Per Drawing	N/A	IAW Para. 5.1.13
J. Rescue Arrow	Fwd. Fuselage	24"	35237

FIGURE C-36. CH-53E aircraft marking (Navy) (tactical).

MIL-STD-2161A(AS)

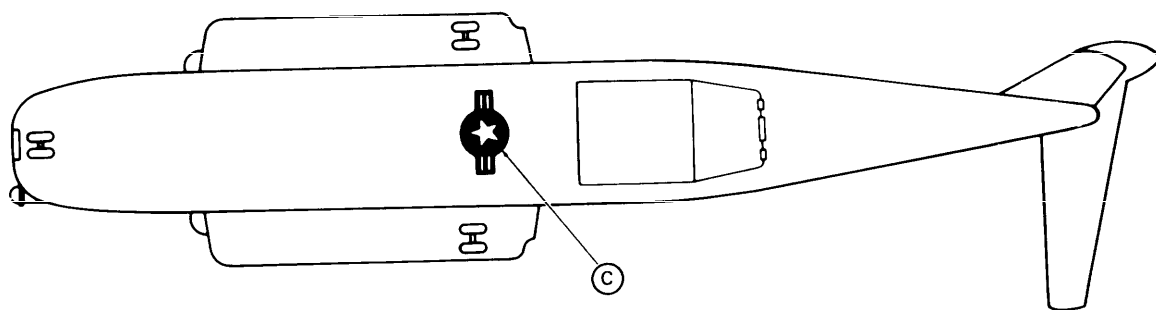
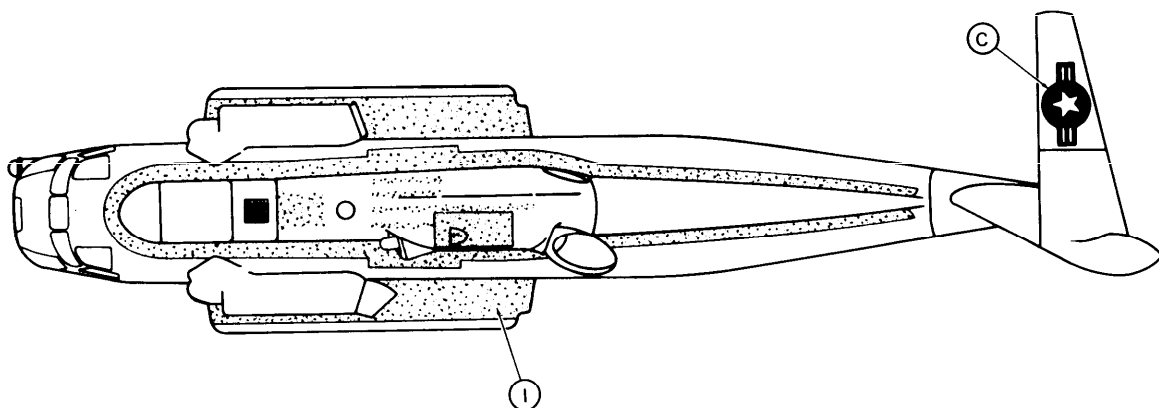


FIGURE C-36. CH-53E aircraft marking (Navy) (tactical) - Continued.

MIL-STD-2161A(AS)

1. MARKING	2. LOCATION	3. SIZE	4. COLOR NO/CODE
A. MARINES	Aft Fuselage	24"	IAW Para 5.2.3.2
B. Model Designation, Acft BUONO	Aft Fuselage	2" 4"	IAW Para 5.2.3.2
C. National Star	Aft Fuselage, Bottom Center Fuselage	25"	IAW Para 5.2.3.2
D. Unit Identification Numbers	Fwd. Lower Fuselage	30"	IAW Para 5.2.3.2
E. Call Numbers	Upper Tail Boom	6"	IAW Para 5.2.3.2
F. Intake Warning	Engine Intake Nacelles	16"	IAW Para 5.2.3.2
G. Beware of Blast	Lower Aft Section L.H. & R.H. Engine Nacelles	2" Letters	IAW Para 5.2.3.2
H. Tail Rotor Warning	Aft Tail Boom	24"	IAW Para 5.2.3.2
I. Walkway	Per Drawing	N/A	35237
J. Rescue Arrow	Fwd. Fuselage	24"	IAW Para 5.2.3.2

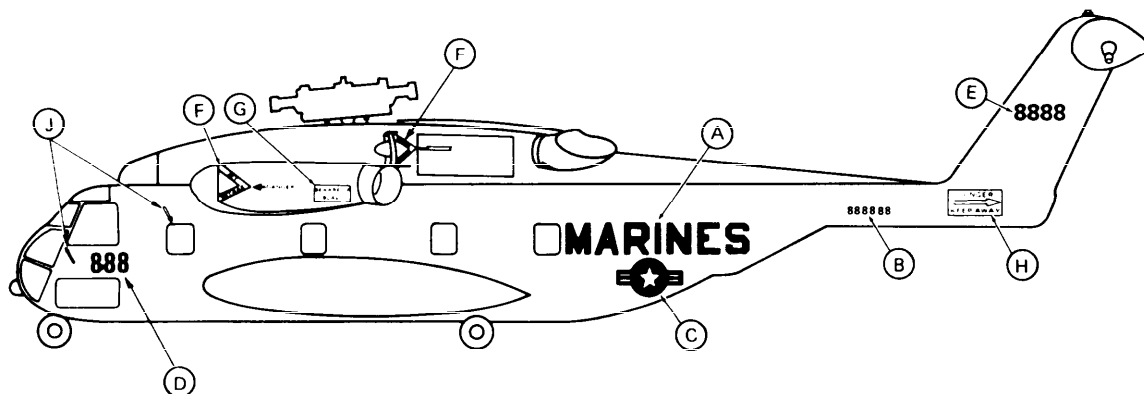


FIGURE C-37. CH-53E aircraft marking (Marine) (tactical).

MIL-STD-2161A(AS)

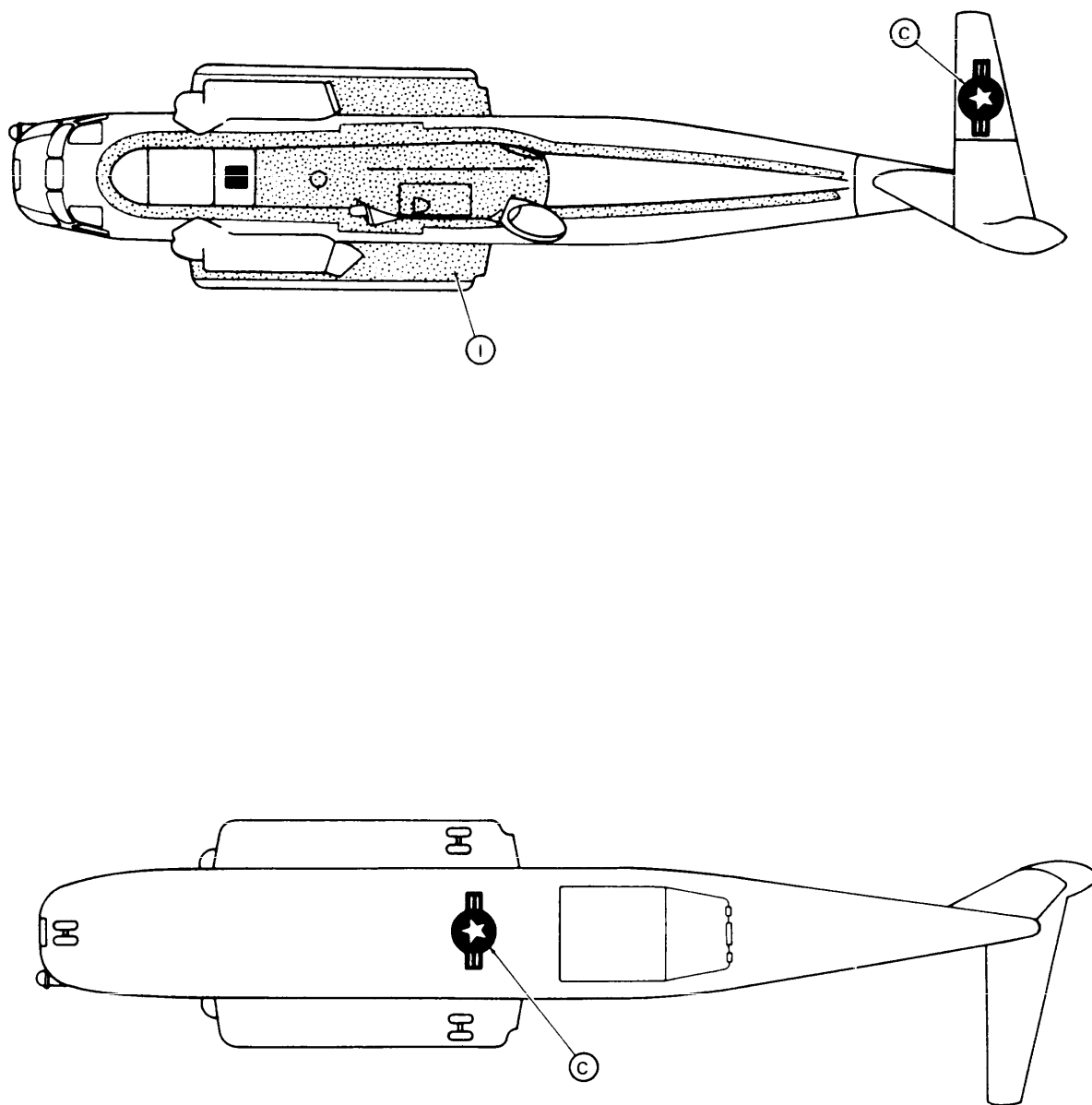


FIGURE C-37. CH-53E aircraft marking (Marine) (tactical) - Continued.

MIL-STD-2161A(AS)

1. MARKING	2. LOCATION	3. SIZE	4. COLOR NO/CODE
A. NAVY	Aft Fuselage	10"	35237
B. Model Designation, Acft BUNO	Side Tail Boom Aft	2" 6"	35237
C. National Star	Mid Fuselage	12" Stars & Bars Rest of Insignia	36320 35237
	Fwd. Top Fuselage	12" Stars & Bars Rest of Insignia	35237 36320
	Aft Bottom Fuselage	12" Stars & Bars Rest of Insignia	36495 36320
D. Intake Warning	Forward Intake Nacelle	15" Background Letters	35237 36320
E. Beware of Blast	Engine Exhaust Nacelle	5" Background Letters	35237 36320
F. Tail Rotor Warning	Tail Boom	33"	35237
G. Antiglare	Fwd. of Cockpit	N/A	
H. Walkway	Per Drawing	N/A	IAW Para. 5.2.3
I. Unit Identifier	Upper Tail Boom	24"	IAW Para. 5.2.3
J. Rescue Arrow	Cockpit Door and Center of Fuselage	24" Background Letters	35237 36320

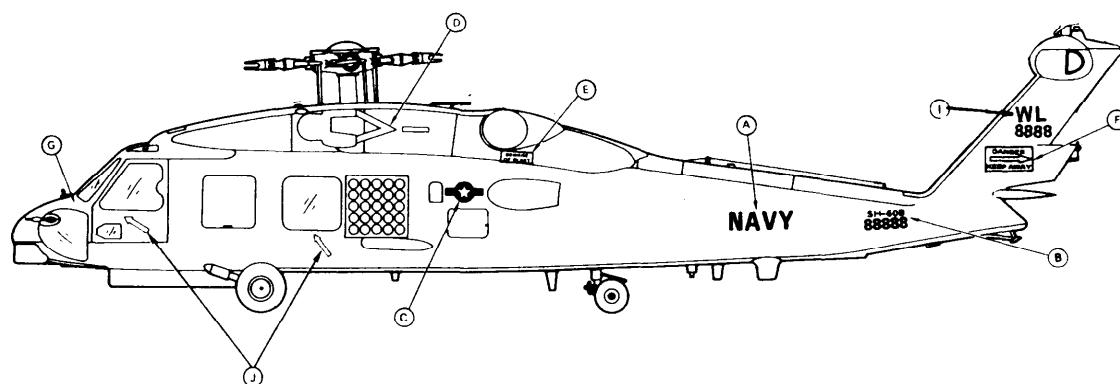


FIGURE C-38. SH-60B aircraft marking (tactical).

MIL-STD-2161A(AS)

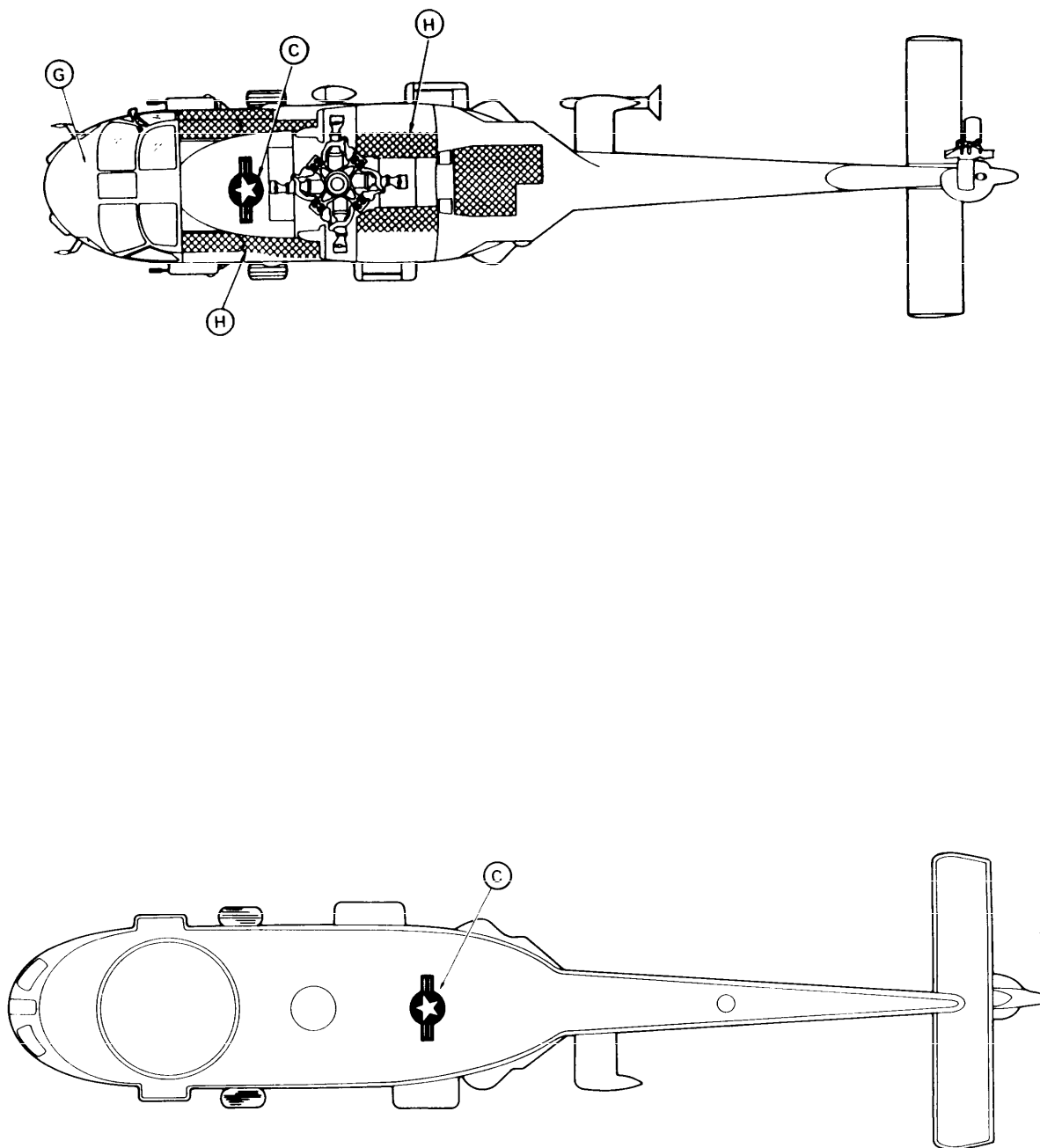
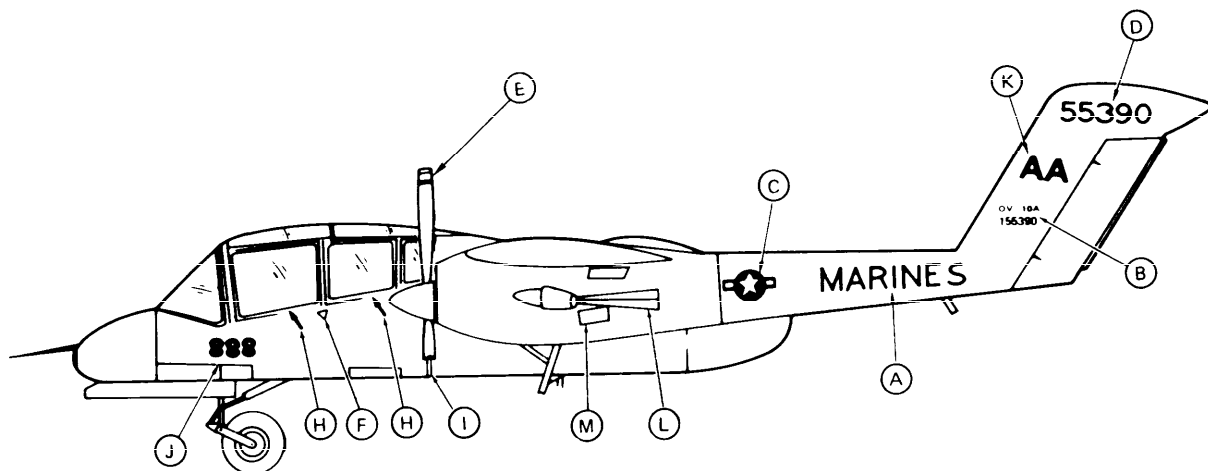


FIGURE C-38. SH-60B aircraft marking (tactical) - Continued.

MIL-STD-2161A(AS)

1. MARKING	2. LOCATION	3. SIZE	4. COLOR NO/CODE
A. MARINES	Boom Outboard Side	10"	IAW Para 5.2.3.2
B. Model Designation, Acft BUNQ	Vertical Stabilizer	2"	IAW Para 5.2.3.2
		4"	IAW Para 5.2.3.2
C. National Star	Boom	10"	IAW Para 5.2.3.2
	Outboard Side		
	Upper L.H. Wing		
	Lower R.H. Wing	10"	
D. Call Numbers	Vertical Stabilizer	9"	IAW Para 5.2.3.2
E. Propeller Tips	N/A	3", 6", 3"	37925/31136/37925
F. Ejection Seat	Below Canopy Rail	9"	IAW Para 5.2.3.2
G. Walkway	Top of Wing	N/A	35237
H. Rescue Arrows	Points to Canopy	24"	IAW Para 5.2.3.2
	Release Handle		
I. Propeller Warning Band	Fwd. Fuselage	3"	IAW Para 5.2.3.2
J. Unit Aircraft Numbers	Fwd. Fuselage	12"	IAW Para 5.2.3.2
K. Unit Identifier	Vertical Stabilizer	24"	IAW Para 5.2.3.2
L. Exhaust Trail	Boom		
	Outboard Side	38"	IAW Para 5.2.3.2
M. Danger Exhaust	Boom	3"	
	Outboard Side	3"	IAW Para 5.2.3.2

FIGURE C-39. OV-10A aircraft marking (tactical).

MIL-STD-2161A(AS)

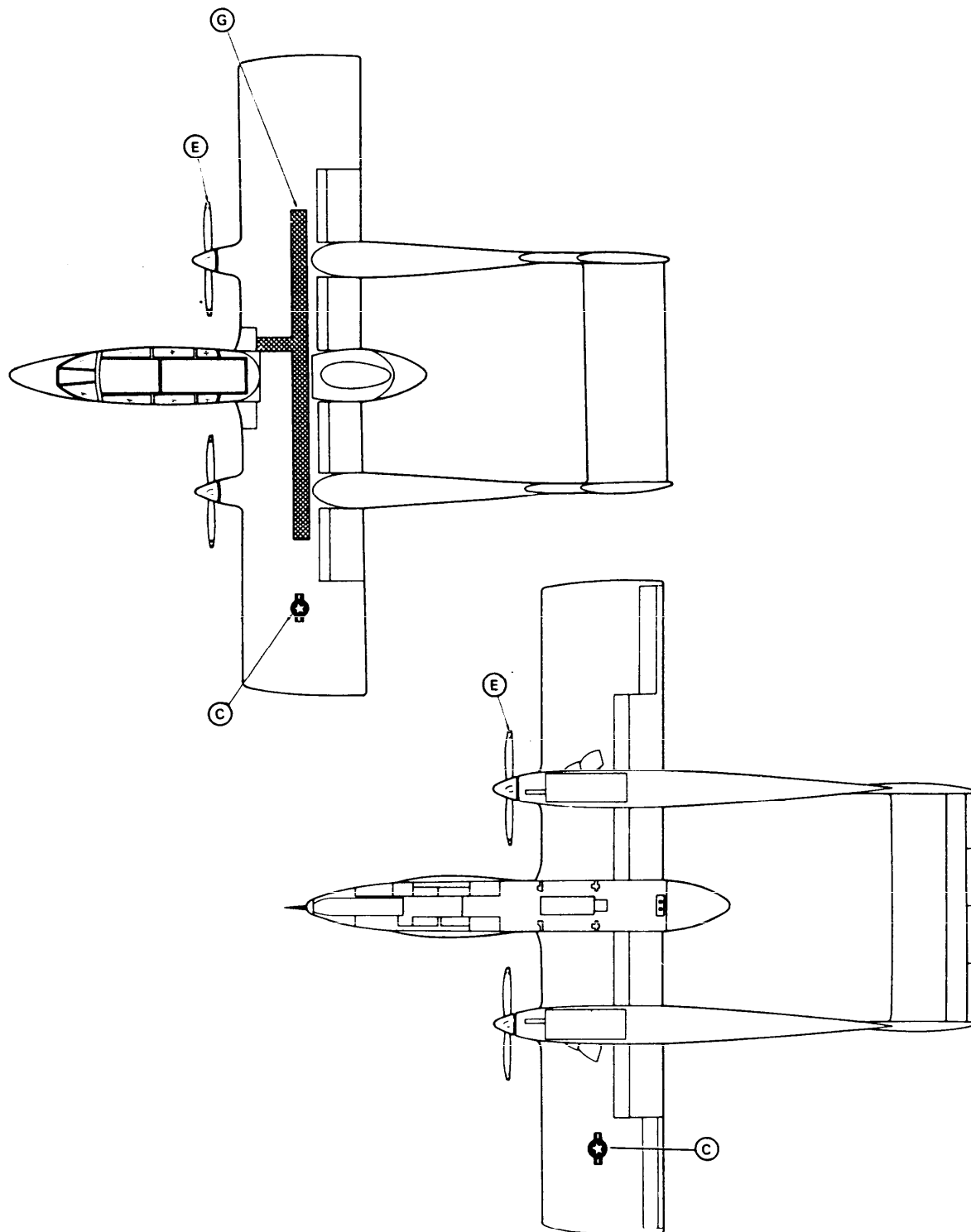
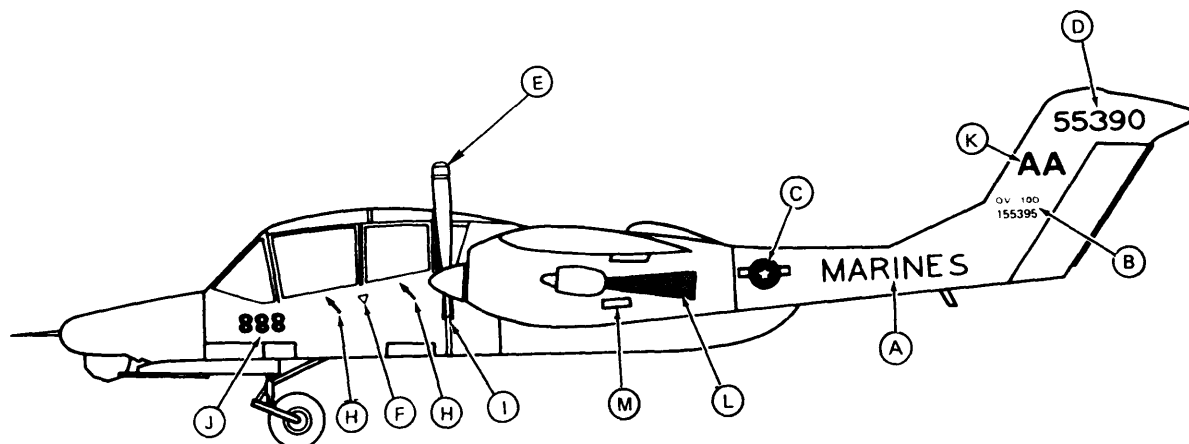


FIGURE C-39. OV-10A aircraft marking (tactical) - Continued.

MIL-STD-2161A(AS)

1. MARKING	2. LOCATION	3. SIZE	4. COLOR NO/CODE
A. MARINES	Boom Outboard Side	10"	IAW Para 5.2.3.2
B. Model Designation, Acft BUNO	Vertical Stabilizer	2" 4"	IAW Para 5.2.3.2 IAW Para 5.2.3.2
C. National Star	Boom Outboard Side Upper L.H. Wing Lower R.H. Wing	10"	IAW Para 5.2.3.2
D. Call Numbers	Vertical Stabilizer	9"	IAW Para 5.2.3.2
E. Propeller Tips	N/A	3", 6", 3"	37925/31136/37925
F. Ejection Seat	Below Canopy Rail	9"	IAW Para 5.2.3.2
G. Walkway	Top of Wing	N/A	35237
H. Rescue Arrows	Points to Canopy Release Handle	24"	IAW Para 5.2.3.2
I. Propeller Warning Band	Fwd. Fuselage	3"	IAW Para 5.2.3.2
J. Unit Aircraft Numbers	Fwd. Fuselage	12"	IAW Para 5.2.3.2
K. Unit Identifier	Vertical Stabilizer	24"	IAW Para 5.2.3.2
L. Exhaust Trail	Boom Outboard Side	38"	IAW Para 5.2.3.2
M. Danger Exhaust	Boom Outboard Side	3" 3"	IAW Para 5.2.3.2

FIGURE C-40. OV-10D aircraft marking (tactical).

MIL-STD-2161A(AS)

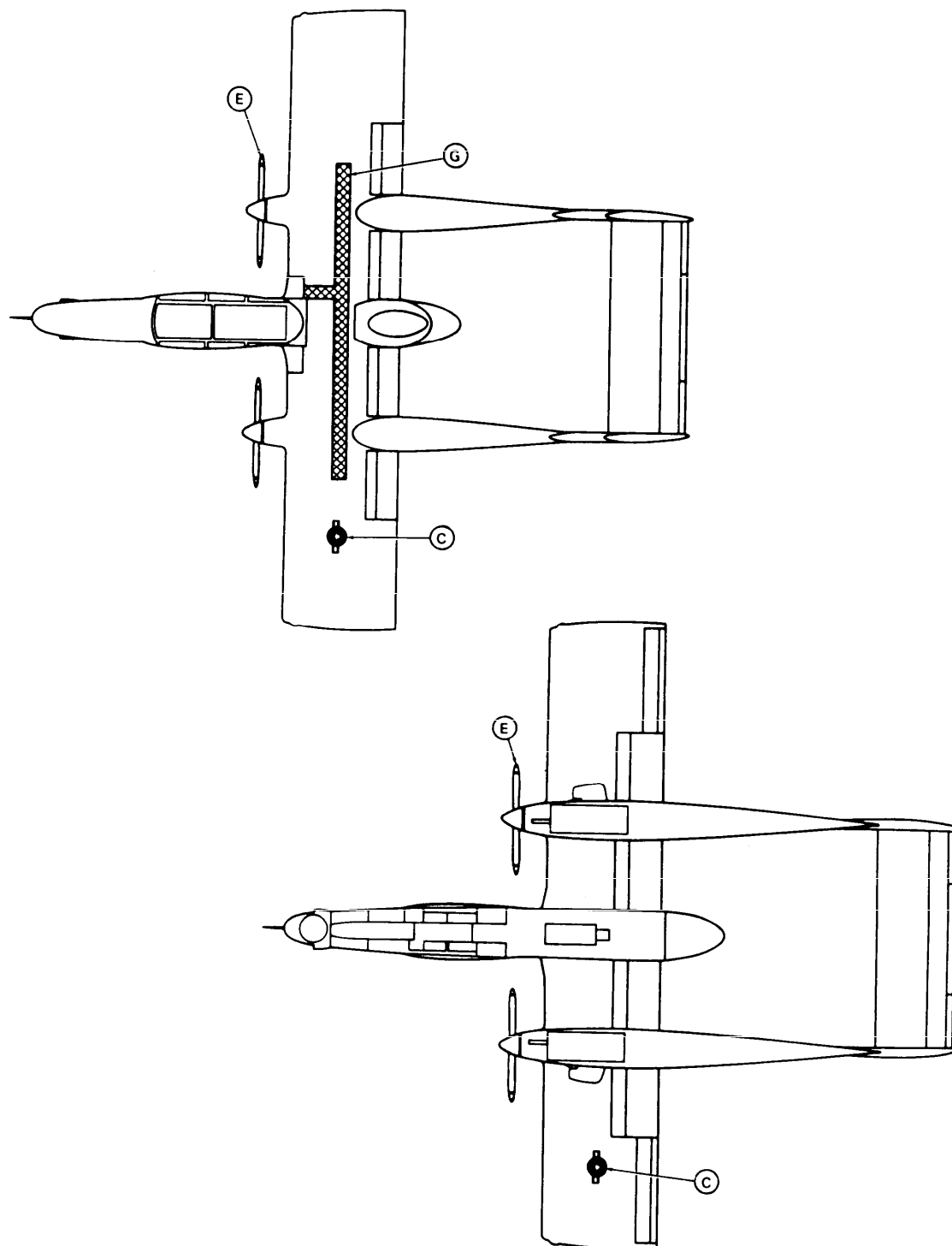
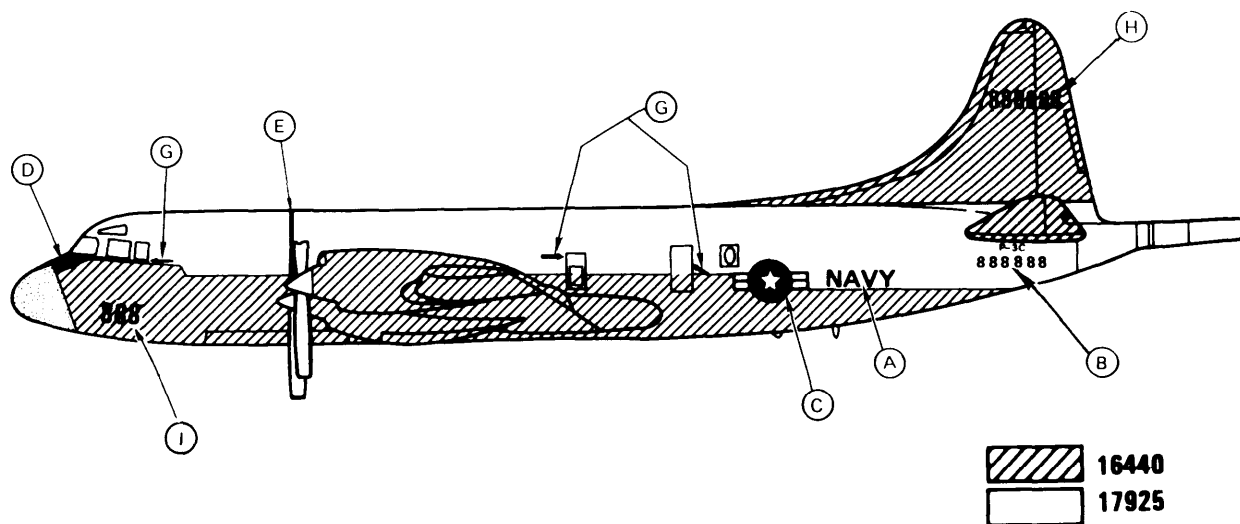


FIGURE C-40. OV-10D aircraft marking (tactical) - Continued.

MIL-STD-2161A(AS)

1. MARKING	2. LOCATION	3. SIZE	4. COLOR NO/CODE
A. NAVY	Aft Fuselage	30"	17038
	Lower L.H. Wing	30"	
B. Model Designation, Acft BUNO	Aft Fuselage Under Horizontal Stabilizer	2"	17038
C. National Star	Aft Fuselage	50"	11136
	Upper L.H. Wing	50"	15044
	Lower R.H. Wing	50"	17925
D. Antiglare	Fwd. of Cockpit	N/A	37038
E. Propeller Warning Band	Forward Fuselage	3"	11136/17925
F. Walkway	Top Surface of Wings	N/A	17038
G. Rescue Arrows	Fwd. Fuselage Aft of Cockpit Windows Mid Fuselage at Doors Top of Fuselage Aft of Hatch	24"	17038/11136
H. Call Numbers	Vertical Stabilizer	12"	17038
I. Unit Aircraft Numbers	Fwd. Fuselage	12"	17038

FIGURE C-41. P-3 aircraft marking.

MIL-STD-2161A(AS)

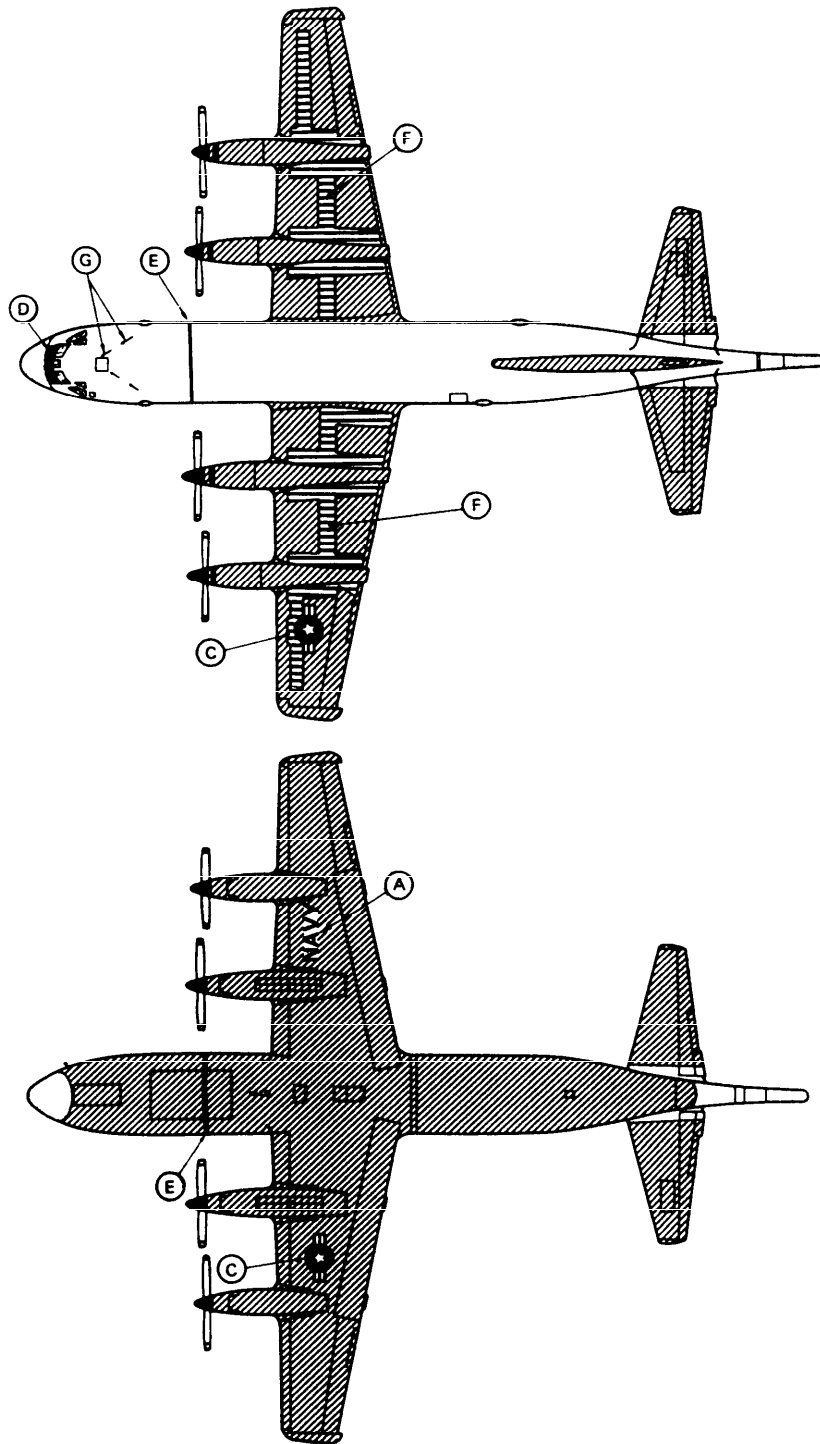


FIGURE C-41. P-3 aircraft marking - Continued.

MIL-STD-2161A(AS)

1. MARKING	2. LOCATION	3. SIZE	4. COLOR NO/CODE
A. NAVY	Aft Fuselage	12"	35237
B. Model Designation, Acft BUNO	Aft Fuselage	4" 2"	35237
C. National Star	Fwd. Fuselage Upper L. H. Wing Lower R. H. Wing	20"	35237
D. Call Numbers	Vertical Stabilizer	9"	35237
E. Arresting Hook Warning	Aft Fuselage Sides	12"	35237
F. Antiglare	Fwd. of Cockpit	N/A	35237
G. Rescue Arrow	Fwd. Fuselage	24"	35237
H. Intake Warning	Fwd. Engine Nacelle	21"	35237
L. Beware of Blast	Aft Engine Pod	12"	35237
J. Walkway	Center Top Fuselage	N/A	36375
K. Ejection Seat Notice	Fwd. Fuselage Beneath Canopy Rail	8"	35237

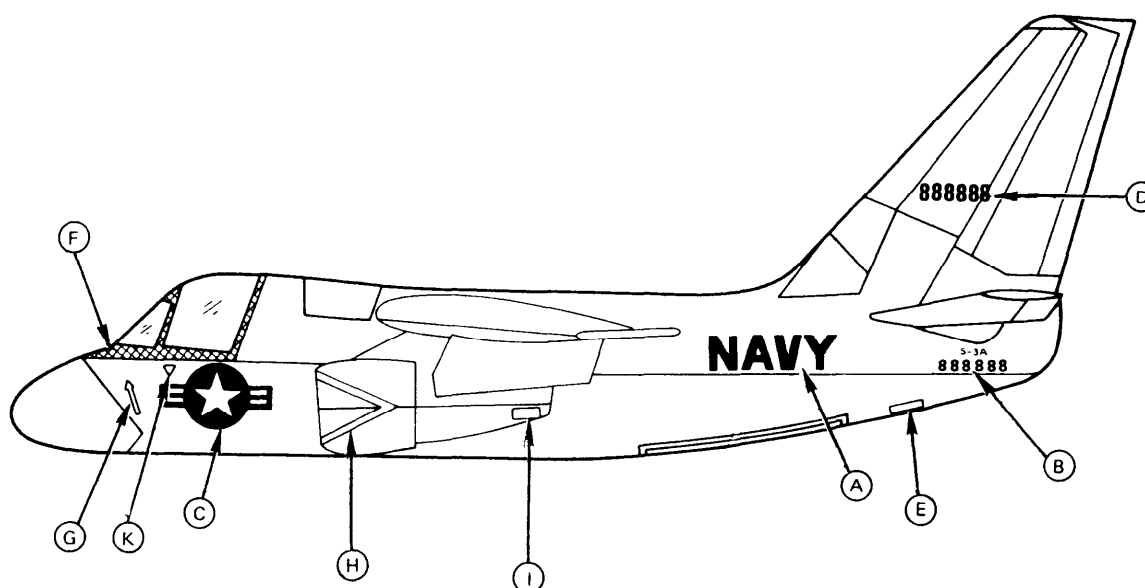


FIGURE C-42. S-3A/B aircraft marking (tactical).

MIL-STD-2161A(AS)

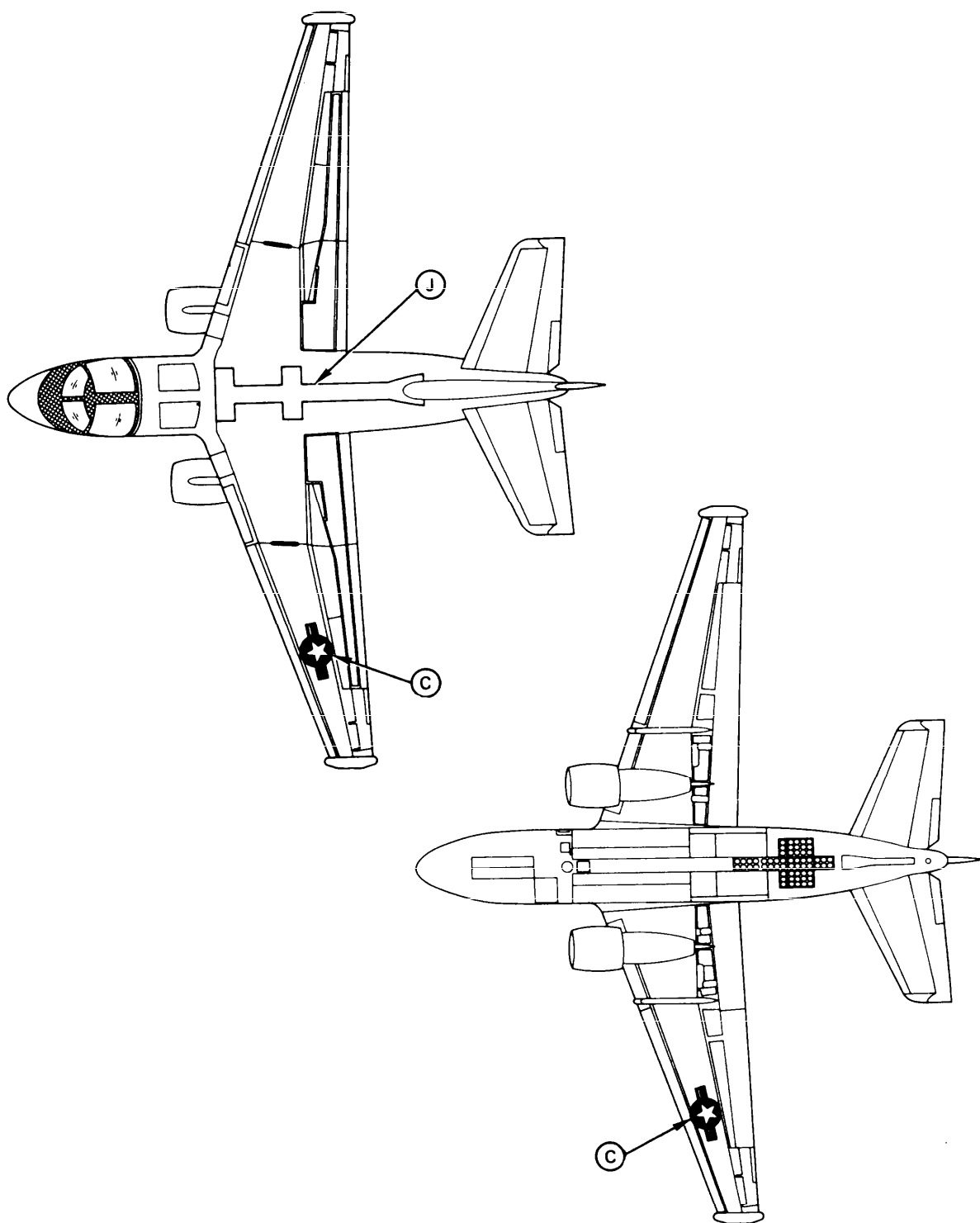


FIGURE C-42. S-3A/B aircraft marking (tactical) - Continued.

MIL-STD-2161A(AS)

1. MARKING	2. LOCATION	3. SIZE	4. COLOR NO/CODE
A. NAVY/MARINES	Aft Fuselage Lower L.H. Wing	12"/10" 24"/16"	17038
B. Model Designation, Acft BUNO	Aft Fuselage	6"	17038
C. National Star	Fwd. Fuselage Lower R.H. Wing Upper L.H. Wing	20" 30" 30"	17925/11136/15044
D. Call Numbers	Vertical Stabilizer	12"	17038
E. Intake Warning	See Para. 5.2.2.10.1	See Para. 5.2.2.10.1	11136
F. Beware of Blast	Aft Fuselage	See Para. 5.2.2.10.2	17925/11136
G. Arresting Hook Warning	N/A	4" Alternating Stripes	17038/17925
H. Ejection Seat	Below Canopy Rail	See Para. 5.2.2.10.6.12	IAW Para. 5.2.3
I. Walkway	Wing Adjacent to Fuselage	N/A	37038
J. Conspicuity Markings	Per Drawing	See Para. 5.1.1.1	12197
K. Antiglare	Fwd. of Cockpit	N/A	37038
L. Unit Aircraft Numbers	Fwd. Fuselage Lower L.H. Wing Upper R.H. Wing	12" 16" 16"	17038
M. Unit Identifier	Vertical Stabilizer Lower L.H. Wing Upper L.H. Wing	20" 16"	17038
N. Rescue Arrow	Fwd. Fuselage	24"	17038/13538

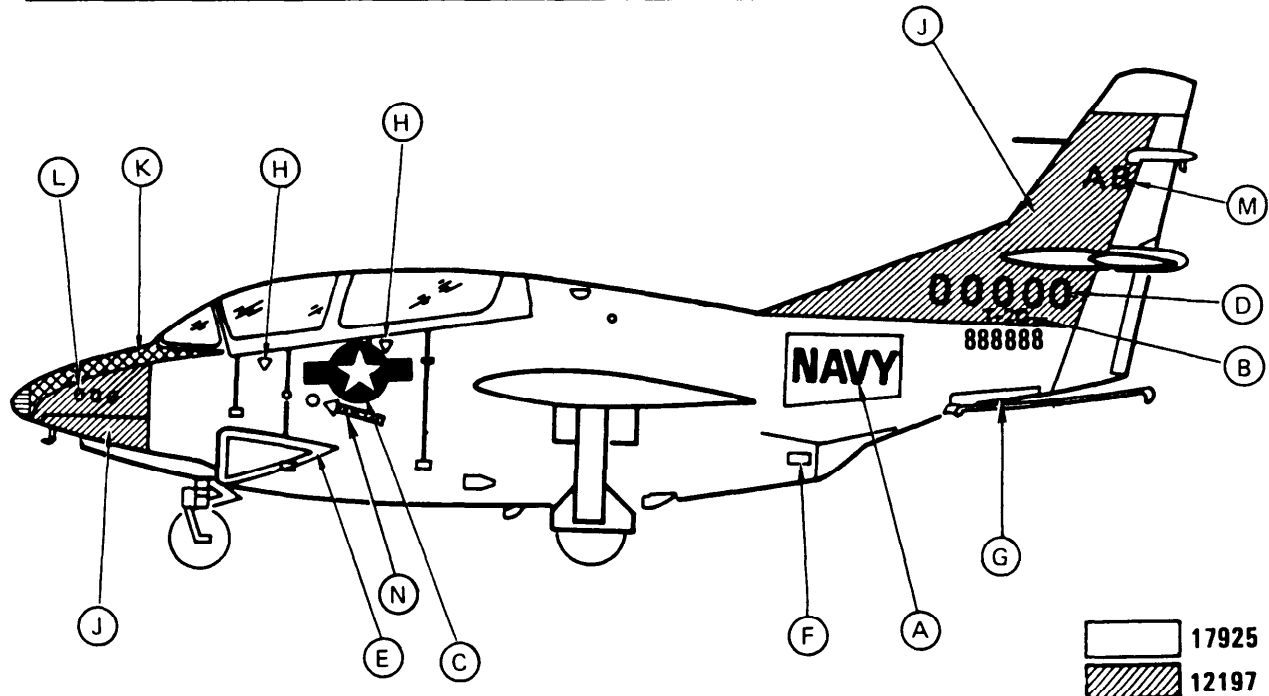


FIGURE C-43. T-2B/C aircraft marking (high visibility).

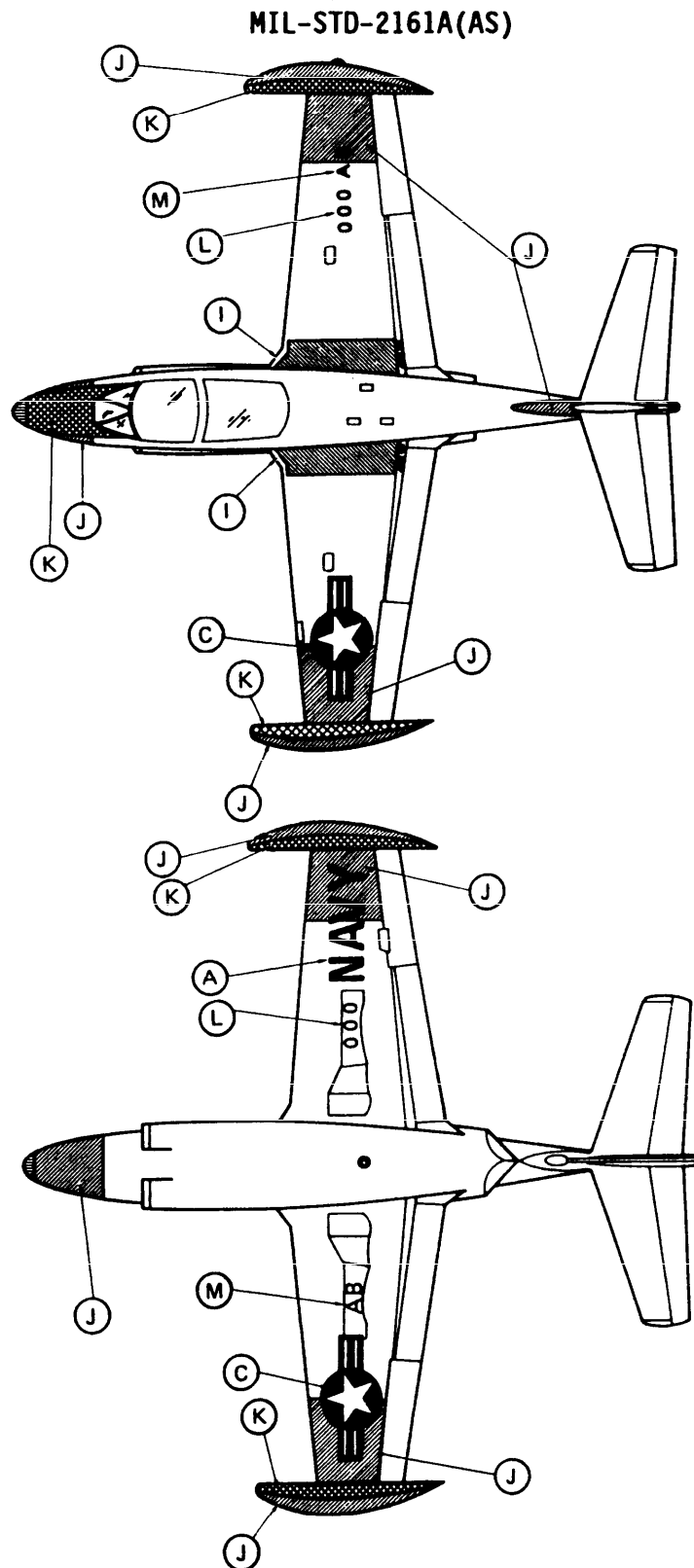


FIGURE C-43. T-2B/C aircraft marking (high visibility) - Continued.

MIL-STD-2161A(AS)

1. MARKING	2. LOCATION	3. SIZE	4. COLOR NO/CODE
A. NAVY	Aft Fuselage Lower R.H. Wing	12" 24"	17038
B. Model Designation, Actf BUNO	Aft Fuselage	2" 4"	17038
C. National Star	Aft Fuselage Lower L.H. Wing Upper R.H. Wing	20" 20" 20"	17875/11136/15044
D. Call Numbers	Lower Vertical Stabilizer	12"	17038
E. Propeller Tips	N/A	3"/6"/3"	17925/11136/17925
F. Antiglare	Propeller Spinner & Fwd. & Aft of Cockpit Canopy	N/A	37038
G. Walkway	Per Drawing	N/A	37038
H. Conspicuity Markings	Engine Cowling, Wing Tips, & Vertical Stabilizer	Per Drawing	12197
I. "Rescue Other Side"	L.H. Side Beneath Canopy Rail	1/4" Letters	17038
J. Rescue Arrow	R.H. Side Beneath Canopy Rail	24"	17038/11136

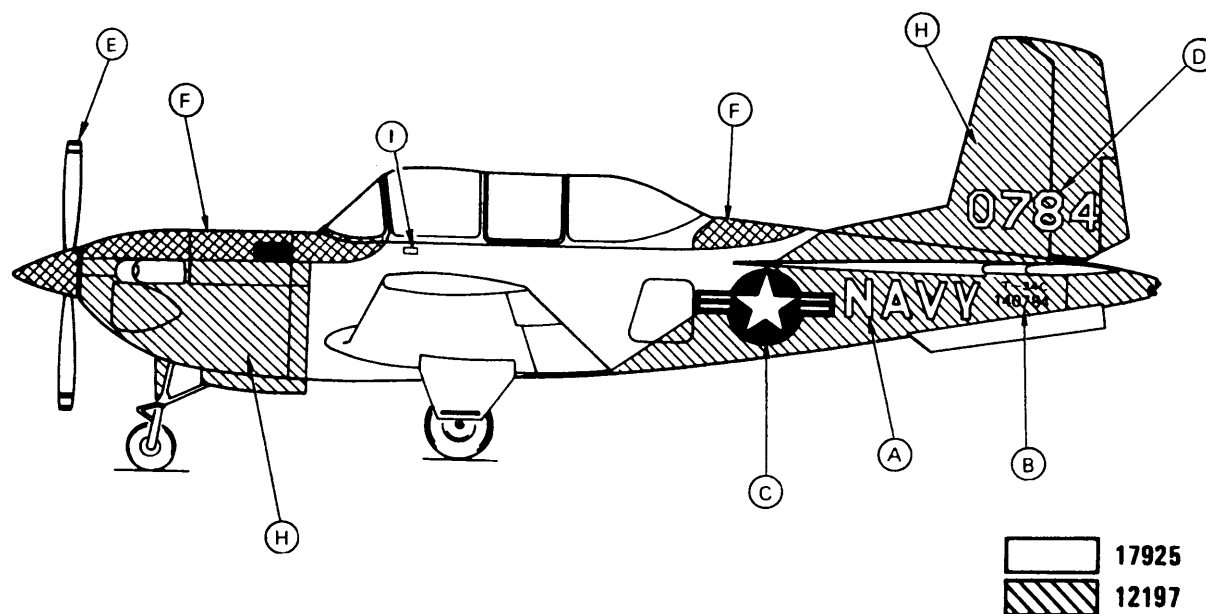


FIGURE C-44. T-34C aircraft marking (high visibility).

MIL-STD-2161A(AS)

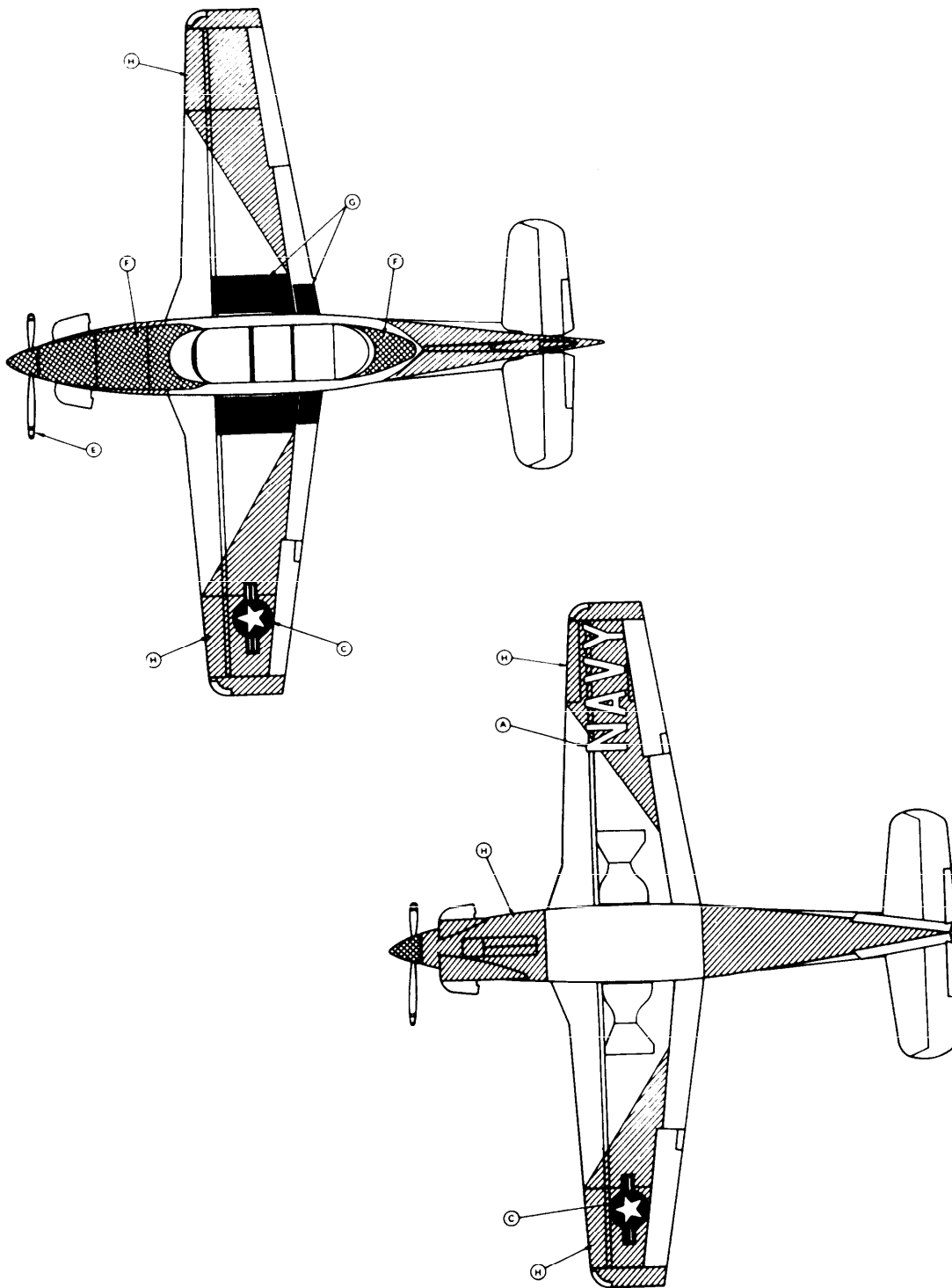
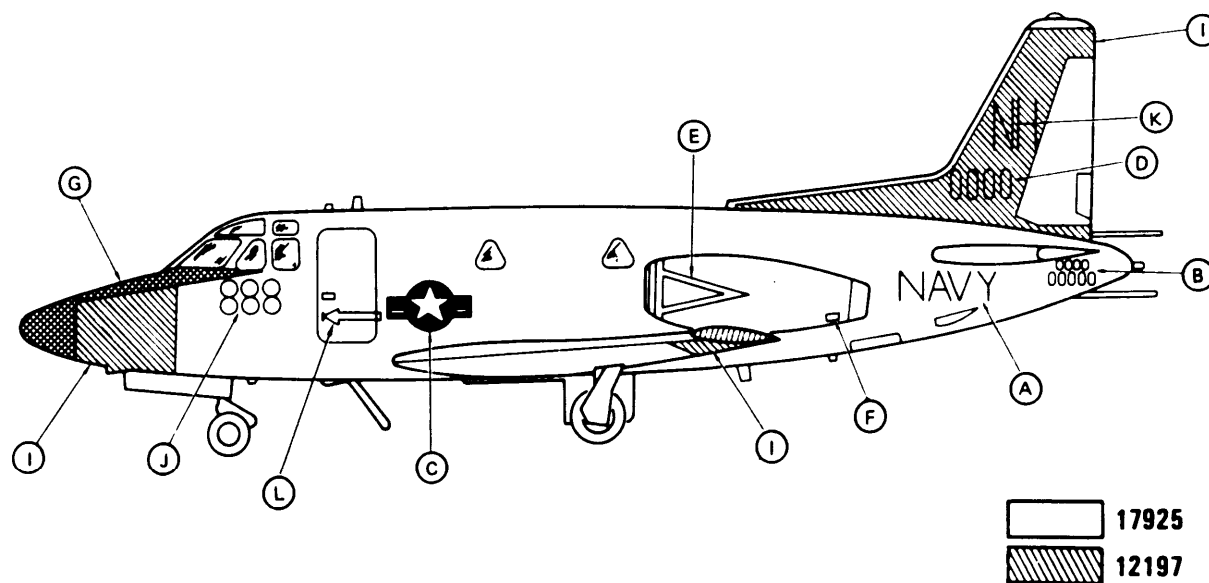


FIGURE C-44. T-34C aircraft marking (high visibility) - Continued.

MIL-STD-2161A(AS)

1. MARKING	2. LOCATION	3. SIZE	4. COLOR NO/CODE
A. NAVY	Aft Fuselage Lower L.H. Wing	16" 20"	17038
B. Model Designation, Acft BUNO	Aft Fuselage	2" 4"	17038
C. National Star	Forward Fuselage Upper L.H. Wing Lower R.H. Wing	20" 30" 30"	11136 15044 17925
D. Call Numbers	Vertical Stabilizer	12"	17038
E. Intake Warning	Fwd. Engine Nacelle	See Para. 5.2.2.10.1	11136
F. Beware of Blast	Aft Engine Nacelle	See Para. 5.2.2.10.2	11136
G. Antiglare	Radome, Fwd. of Cockpit	N/A	37038
H. Walkway	Wings & Engine Mounts Next to Fuselage	N/A	37038
I. Conspicuity Markings	Per Drawing	See Para. 5.1.1.1	12197
J. Unit Aircraft Numbers	Fwd. Fuselage Lower L.H. Wing Upper R. H. Wing	16" 16" 20"	17038
K. Unit Identifier	Vertical Stabilizer Lower R.H. Wing Upper R.H. Wing	20" 16" 24"	17038
L. Rescue Arrow	Fwd. Fuselage Door	24"	17038 13538
M. Bare Metal & Polish	Engine Intake Lip Engine Exhaust Shroud	N/A	N/A

FIGURE C-45. T-39 aircraft marking (high visibility).

MIL-STD-2161A(AS)

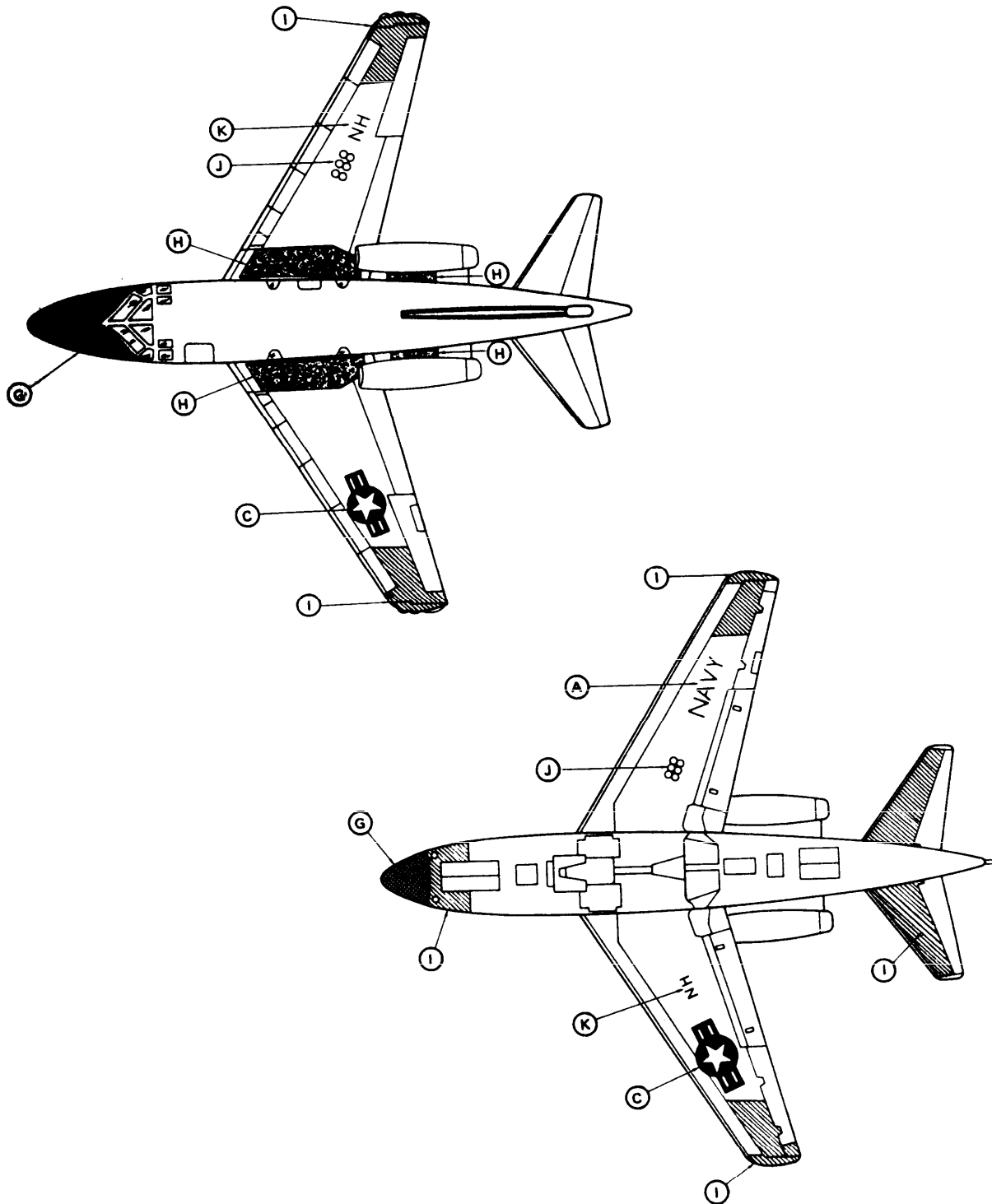


FIGURE C-45. T-39 aircraft marking (high visibility) - Continued.

MIL-STD-2161A(AS)

1. MARKING	2. LOCATION	3. SIZE	4. COLOR NO/CODE
A. NAVY	Lower L.H. Wing Aft Fuselage	20" 16"	17038
B. Model Designation, Acft BUONO	Aft Fuselage	2" 4"	17038
C. National Star	Fwd. Fuselage Upper L.H. Wing Lower R.H. Wing	20" 30" 30"	11136 15044 17925
D. Call Numbers	Vertical Stabilizer	12"	17038
E. Intake Warning	Engine Intake Nacelle	See Para. 5.2.2.10.1	11136
F. Beware of Blast	Engine Exhaust Nacelle	See Para. 5.2.2.10.2	11136
G. Walkway	Wings & Engine Mounts Next to Fuselage	N/A	37038
H. Antiglare	Radome & Fwd. of Cockpit	N/A	37038
I. Unit Identifier	Fwd. Fuselage Upper R.H. Wing Lower L.H. Wing	16" 20" 16"	17038
J. Unit Aircraft Numbers	Vertical Stabilizer Upper R.H. Wing Lower R.H. Wing	20" 24" 16"	17038
K. Bare Metal and Polish	Engine Intake Lip Engine Exhaust Shroud	N/A	N/A
L. Rescue Arrow	Fwd. Fuselage Door	24"	17038 13538

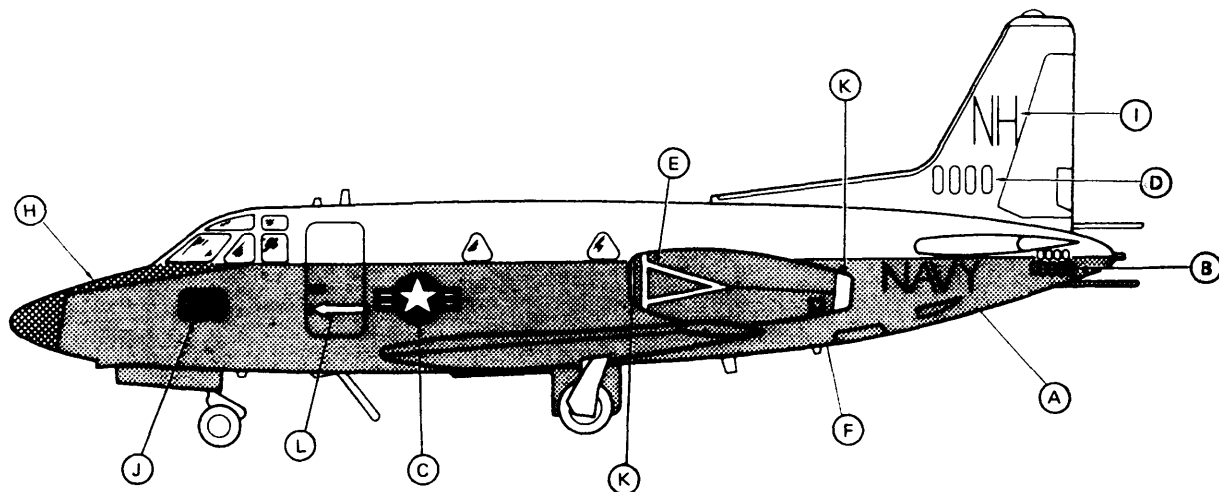


FIGURE C-46. T-39 aircraft marking (cargo).

MIL-STD-2161A(AS)

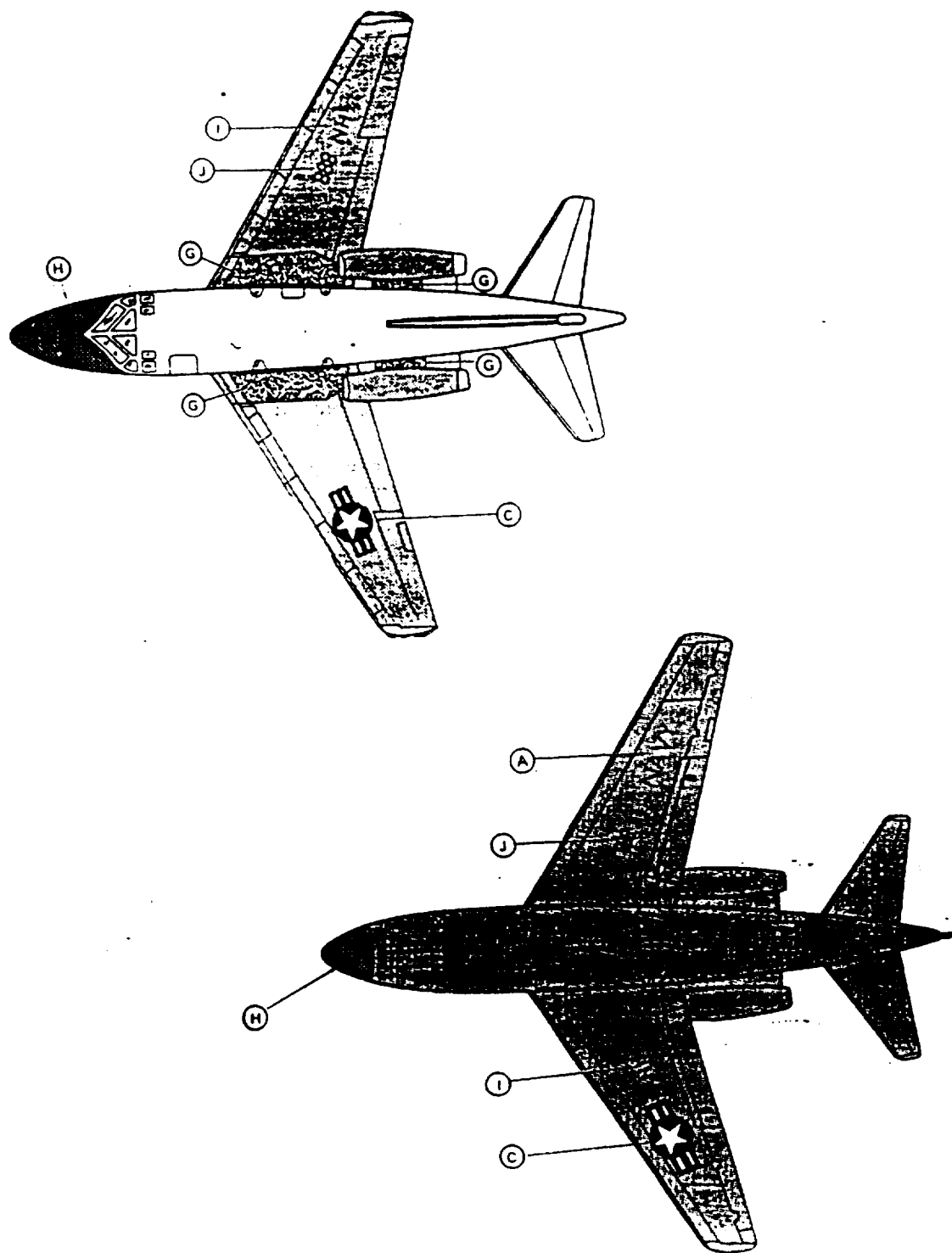
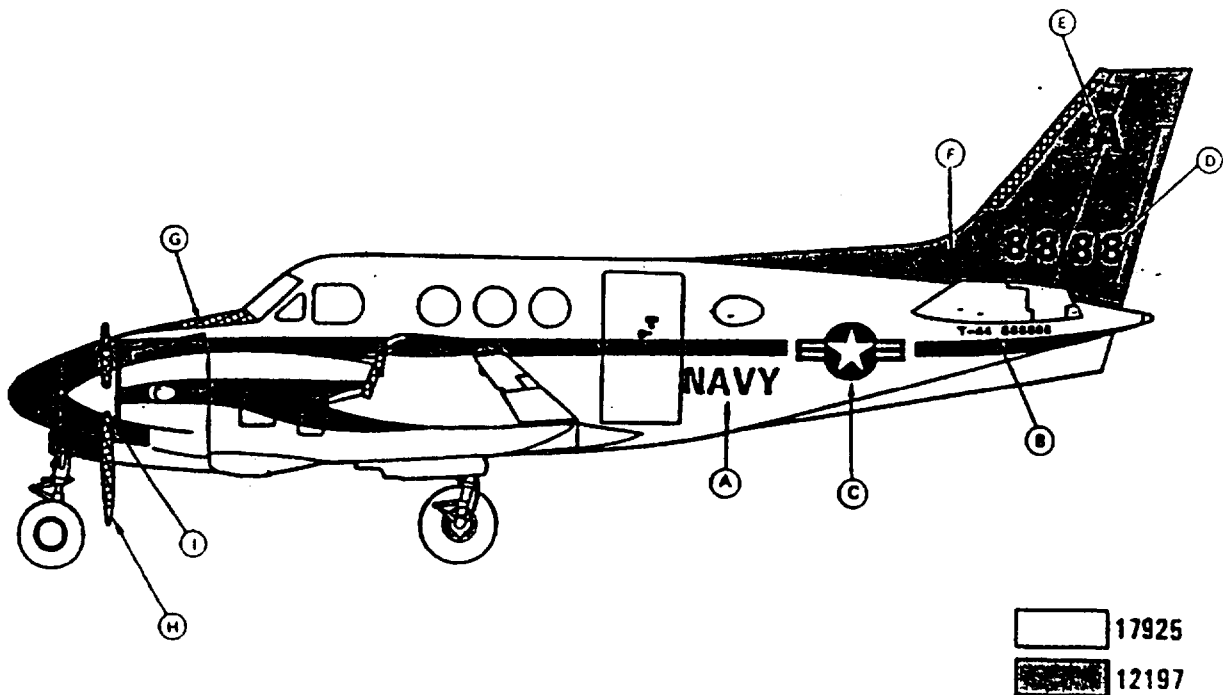


FIGURE C-46. T-39 aircraft marking (cargo) - Continued.

MIL-STD-2161A(AS)

1. MARKING	2. LOCATION	3. SIZE	4. COLOR NO/CODE
A. NAVY	Aft Fuselage Lower L. H. Wing	16"	17038
B. Model Designation, Acft BUONO	Side Aft Fuselage	2" 4"	17038
C. National Star	Aft Fuselage Upper L. H. Wing Lower R. H. Wing	20"	11136 15044 17925
D. Call Numbers	Vertical Stabilizer	16"	17038
E. Unit Identifier	Top Vertical Stabilizer	24"	17038
F. Conspicuity Markings	Per Drawing	See Para. 5.1.1.1	12197
G. Antiglare	Nose Fwd. of Windscreen inside of L&R Nacelles	N/A	37038
H. Propeller Tips	N/A	6"	17925 11136
I. Propeller Warning Band	Fwd. Fuselage	3" Wide	17925/11136

FIGURE C-47. T-44A aircraft marking (high visibility).

MIL-STD-2161A(AS)

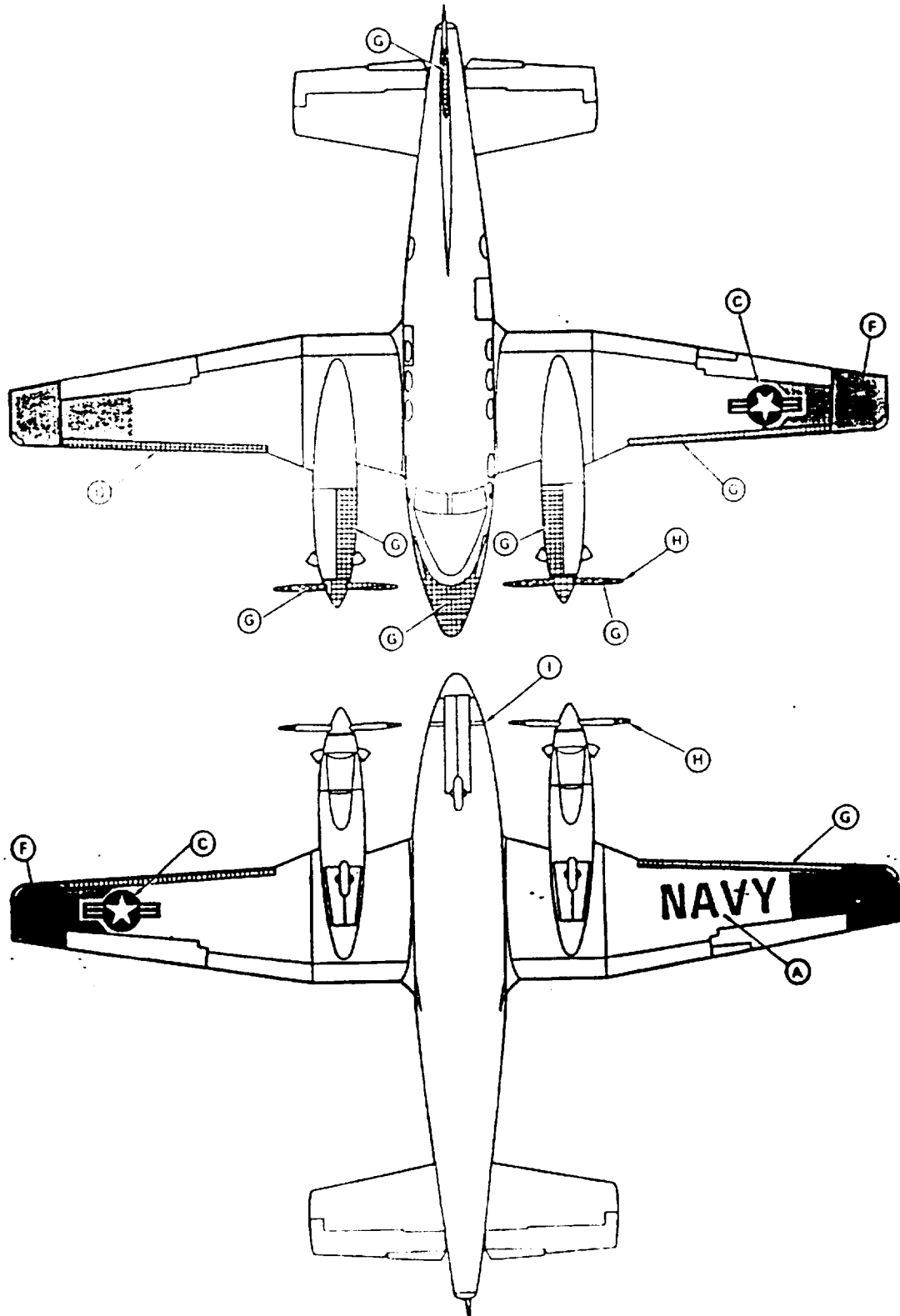


FIGURE C-47. T-44A aircraft marking (high visibility) - Continued.

MIL-STD-2161A(AS)

1. MARKING	2. LOCATION	3. SIZE	4. COLOR NO/CODE
A. UNITED STATES NAVY UNITED STATES MARINES	Center Fuselage	8"	17038
B. Model Designation, Aeft BUNO	Side Aft Fuselage	2" 4"	17038
C. National Star	Aft Fuselage Upper L.H. Wing Lower R.H. Wing	20" 20" 20"	11136 15044 17925
D. Call Numbers	Vertical Stabilizer	12"	17038
E. Unit Identifier	Upper Vertical Stabilizer	18"	17038
F. Accent Stripes MARINE NAVY	Center Fuselage Center Fuselage	6" each 6" each	Upper 11136/Lower 17043 Upper 15066/Lower 17043
G. Flag - United States	Upper Vertical Stabilizer	Sec Para. 5.2.7	11136/15044/17925
H. Antiglare	Nose Fwd. of Wind Screen Inside L. & R. Nacelles	N/A	37038
I. Propeller Tips	N/A	6"	17925/11136
J. Propeller Warning Band	Fwd. Fuselage	3" Wide	11136/17925

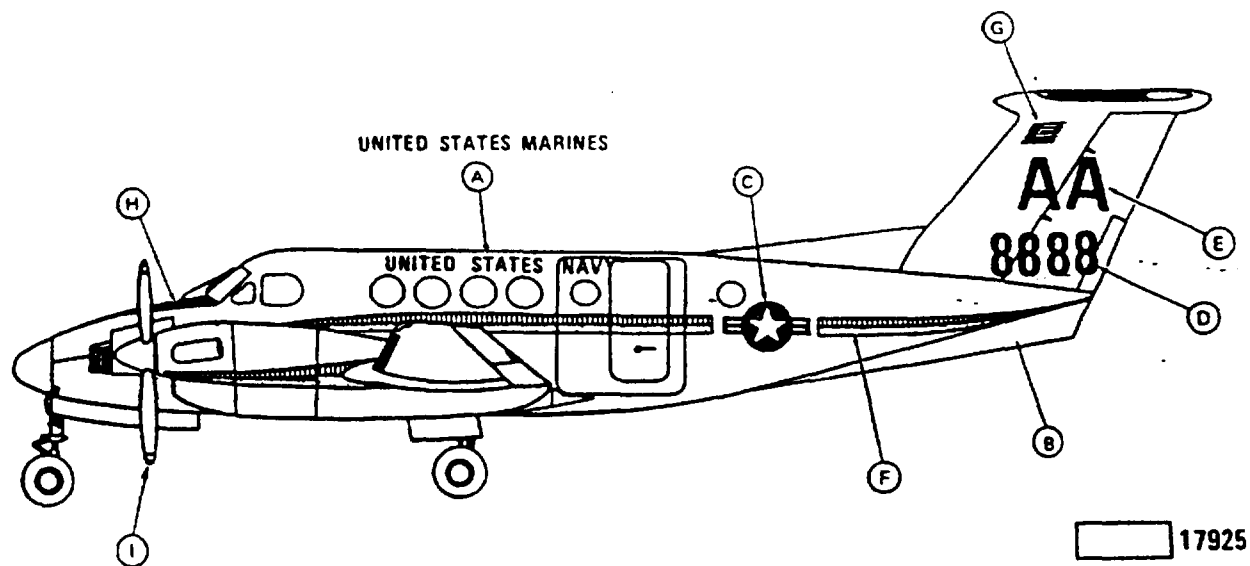


FIGURE C-48. UC-12B aircraft marking.

MIL-STD-2161A(AS)

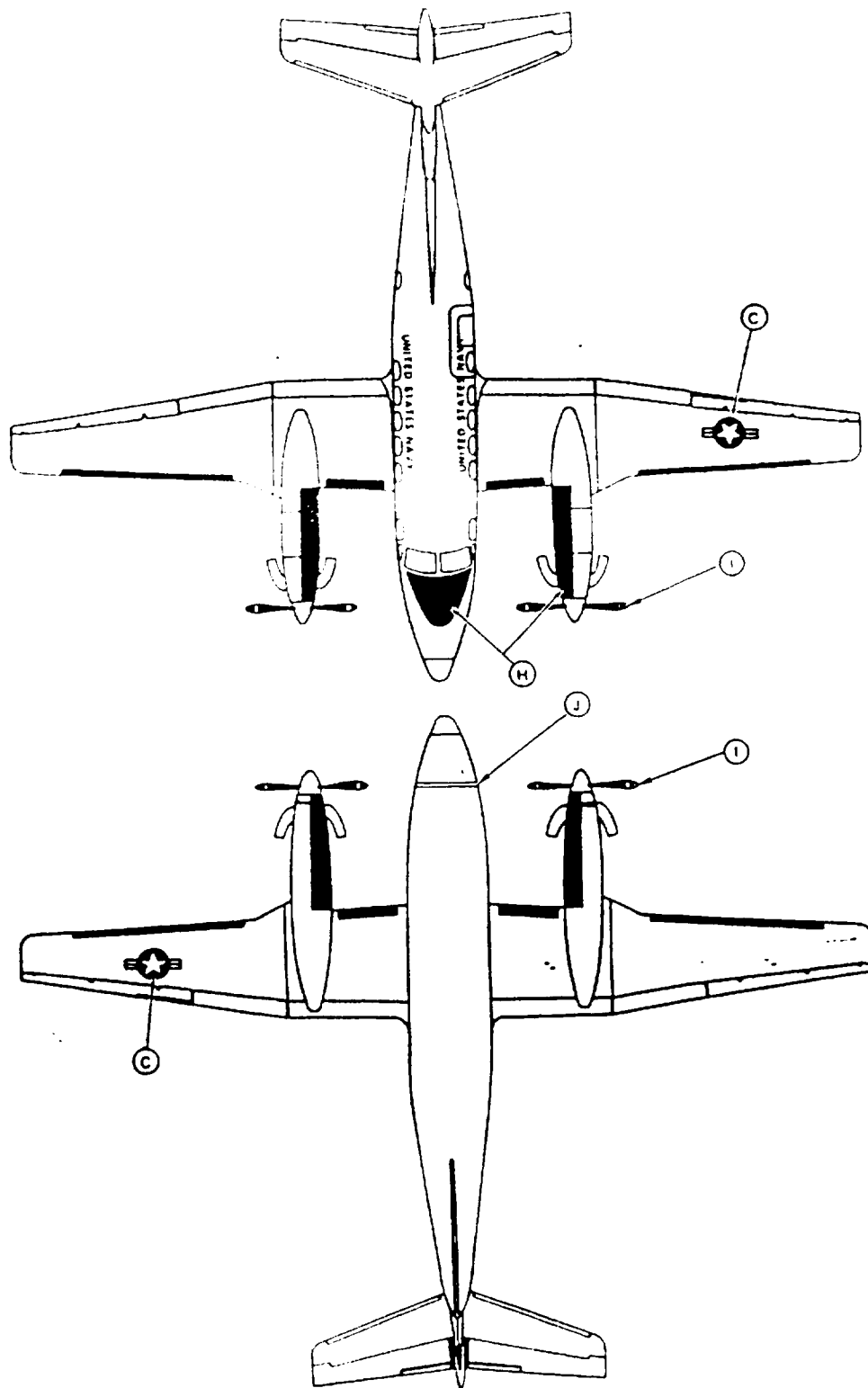
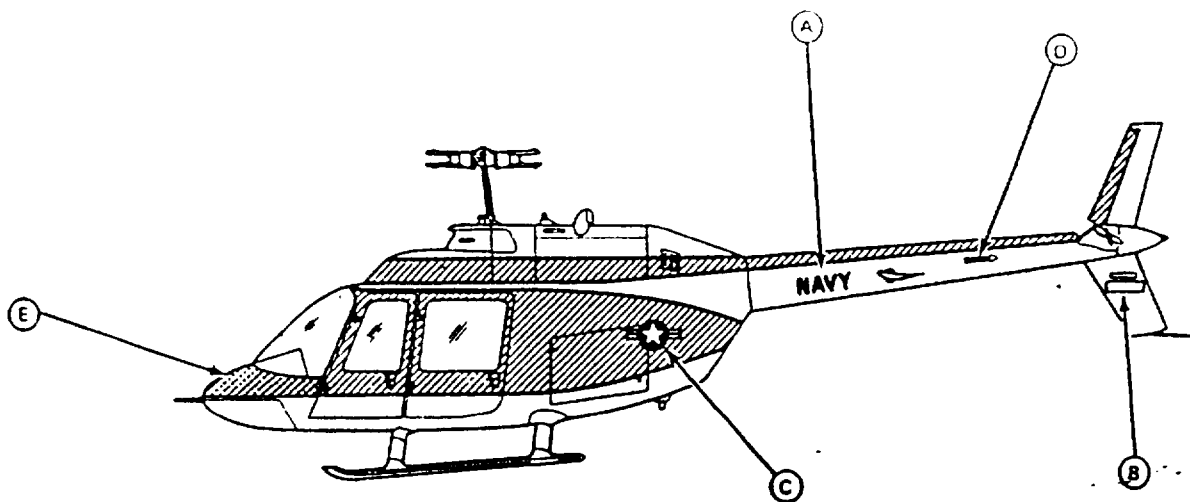


FIGURE C-48. UC-12B aircraft marking - Continued.

MIL-STD-2161A(AS)

1. MARKING	2. LOCATION	3. SIZE	4. COLOR NO/CODE
A. NAVY	Tail Boom	6"	17038
B. Model Designation, Actt BU/NO	Both Sides of Tailboom	2" 4"	17038
C. National Star	Aft Fuselage Bottom Fuselage	10" 10"	17923/11136/15044
D. Tail Boom Warning	Tail Boom	22"	31136/37038
E. Anti Glare			37038
F. Arctic Markings/ Conspicuity	As Per Drawing		12197
G. Unit Identifying Letters	Tail Boom (IAW Para. 5.2.3)		17038







	17038
	37038
	12197
	17875

FIGURE C-49. TH-57 aircraft marking (high visibility).

MIL-STD-2161A(AS)

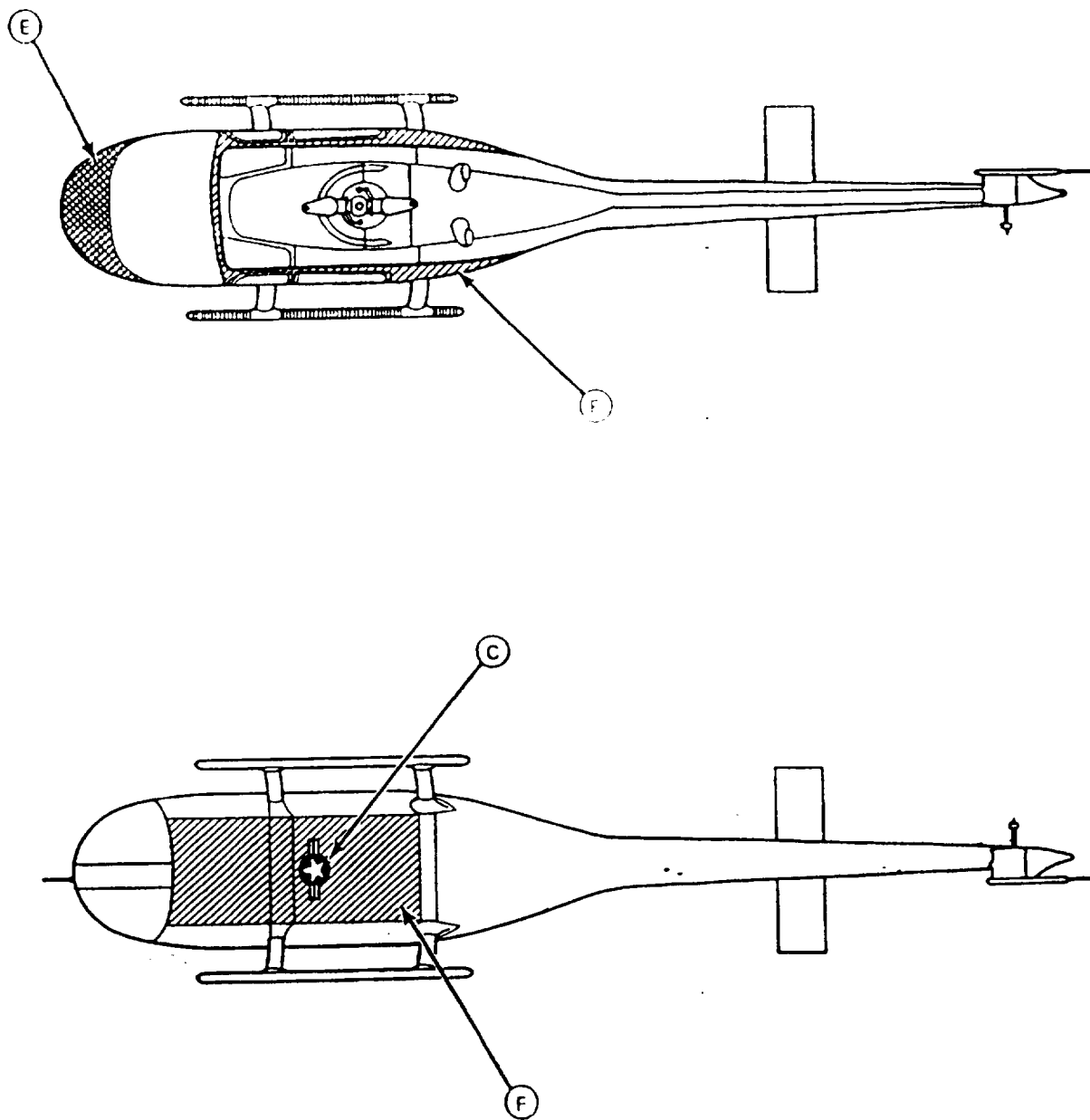
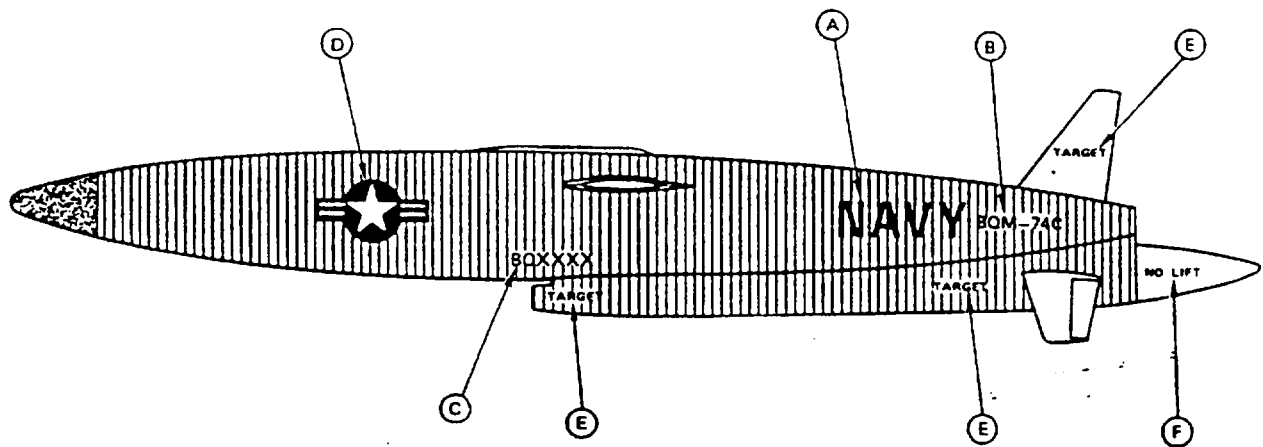


FIGURE C-49. TH-57 aircraft marking (high visibility) - Continued.

MIL-STD-2161A(AS)

1. MARKING	2. LOCATION	3. SIZE	4. COLOR NO/CODE
A. NAVY	Aft Fuselage & L.H. Lower Wing Surface	5"	17038/37038
B. Model Designation	Aft Fuselage	2 1/2" (Decal 94743-17)	17038/37038
C. Drone Serial No.	Center Fuselage Above Air Scoop	2" (Decal 94743-18)	17038/37038
D. National Star	Fwd. Fuselage and R.H. Lower Wing Surface	NV-STD-158-8	
E. Target	Air Scoop, Aft Fuselage, R.H. & L.H. Upper Wing Tips, & Vertical Stabilizer	(Decal 32962-1)	
F. No Lift	Center of Tail Cone	(Decal 32962-2)	







	WHITE RAIN EROSION COATING
	12197
	37925
	11136

FIGURE C-50. BQM-74C drone marking.

MIL-STD-2161A(AS)

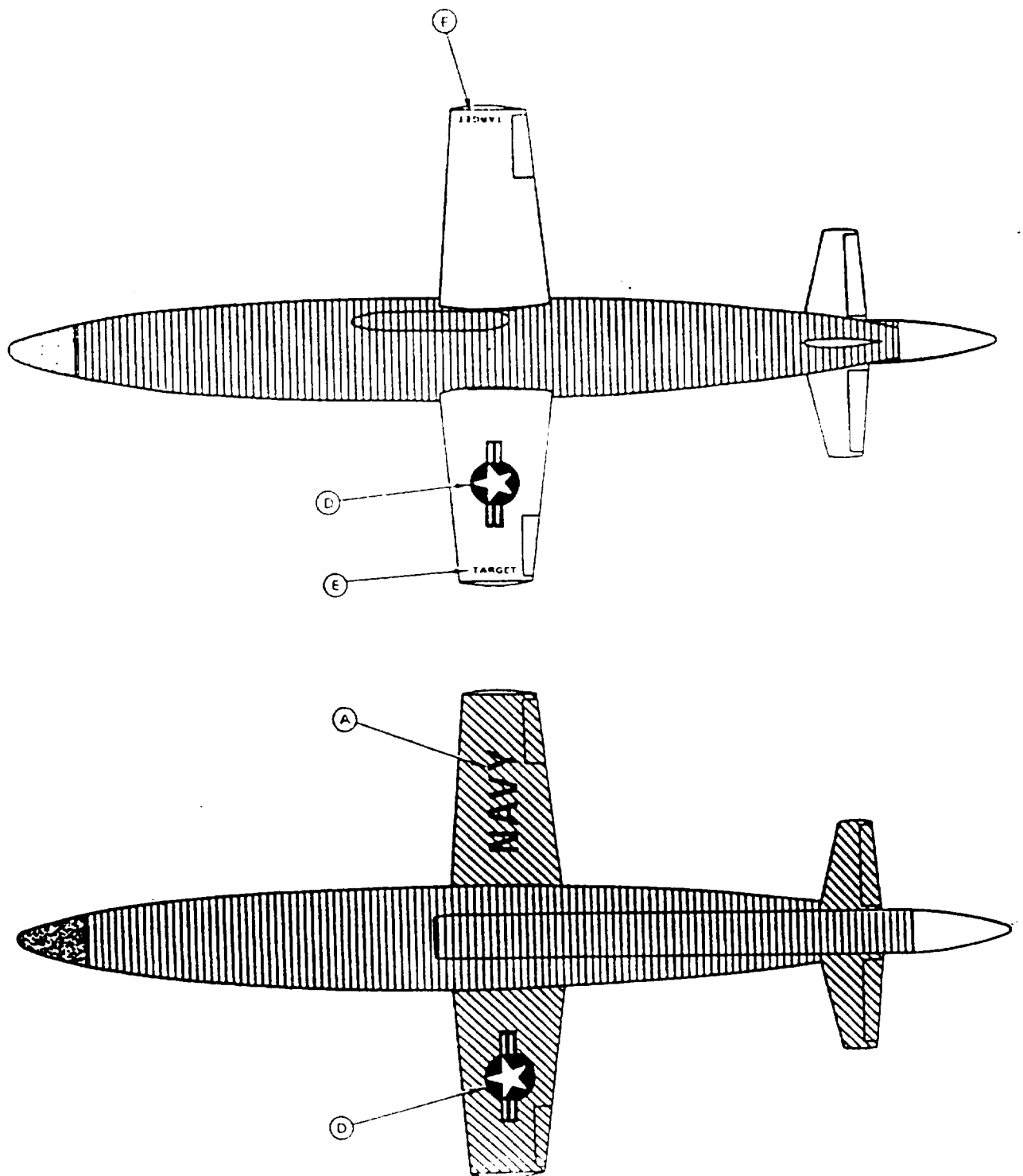


FIGURE C-50. BOM-74C drone marking - Continued.

MIL-STD-2161A(AS)

1. MARKING	2. LOCATION	3. SIZE	4. COLOR NO/CODE
A. NAVY/MARINES	Tail Boom/ Bottom Fuselage	10"	17038
B. Model Designation, A/cft BUNO	Side Tail Boom	2" 6"	17038
C. National Star	Aft Fuselage Top Fuselage Bottom Fuselage	15" 15" 15"	17925/11136/15044
D. Intake Warning	Forward Intake	15"	11136/17925
E. Beware of Blast	Engine Exhaust Nacelle	5"	11136/17925
F. Tail Rotor Warning	Tail Boom	33"	13538/31136/17038
G. Antiglare	Fwd. Fuselage	N/A	37038
H. Walkway	Top Fuselage	N/A	37038
I. Unit Aircraft Numbers	Mid Fuselage Bottom Fuselage	10"	17038
J. Unit Identifier	Tail Boom Bottom Fuselage	15"	17038
K. Rescue Arrow	Fwd. Cockpit Door	24"	13538/17925
L. Rescue	Bottom Aft Fuselage Top Fwd. Fuselage	10"	17038
M. Abandon Chute	Bottom Fuselage	10"	17038
N. Conspicuity Markings	Per Drawing	N/A	12197

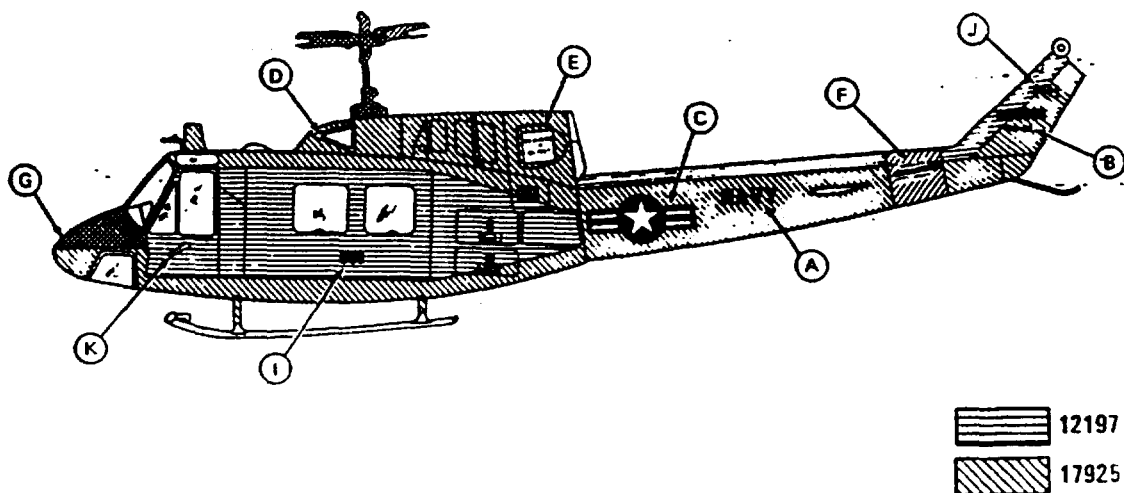


FIGURE C-51. UH-1N aircraft marking (non-combat SAR).

MIL-STD-2161A(AS)

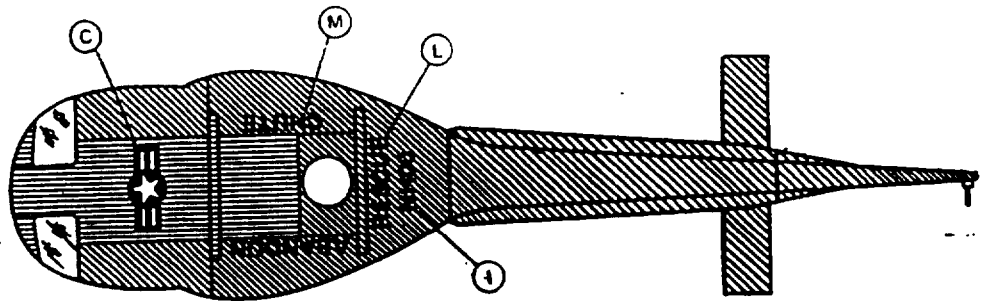
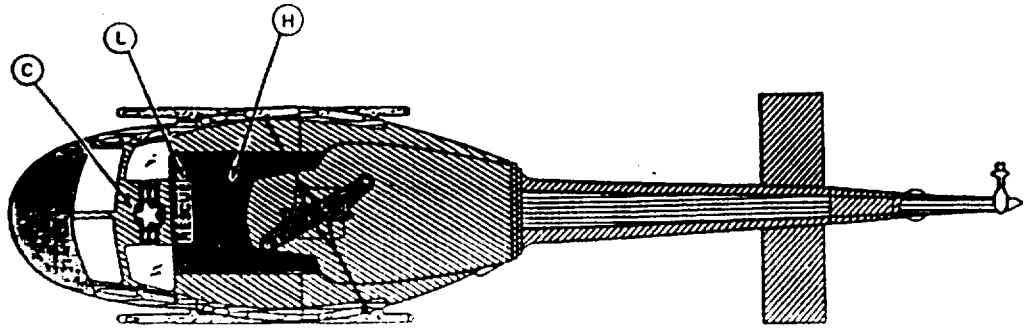


FIGURE C-51. UH-1N aircraft marking (non-combat SAR) - Continued.

MIL-STD-2161A(AS)

1. MARKING	2. LOCATION	3. SIZE	4. COLOR NO/CODE	
A. NAVY	Lower Fuselage Aft Fuselage	12"	35237	
B. Model Designation, Acft BUONO	Aft Fuselage	2" 4"	35237	
C. National Star	Upper Tail Boom	12"	35237	36320
	Lower Fuselage	12"	36320	36495
	Center Fuselage	12"	36495	35237
D. Unit Aircraft Number	Forward Fuselage	12"	IAW Para 5.2.3	
E. Call Numbers	Lower Aft Fuselage	12"	35237	
F. Intake Warning	Fwd. Engine Nacelle	16"	Background	35237
			Letters	36320
G. Beware of Blast	Aft Engine Nacelle	22"	Background	35237
			Letters	36320
H. Tail Rotor Warning	Aft Fuselage	29"	35237	
I. Antiglare	Nose Fwd. of Cockpit	N/A	35237	
J. Unit Identifier	Tail Boom	10"	IAW Para 5.2.3	
K. Tip Marking	Horizontal Stabilizer	6"	36320	
L. Rescue Arrow	Fwd. and Center Fuselage	24"	Background	35237
	L.H. & R.H Sides			
	Letters			
M. Walkway	Top Fuselage	N/A	IAW Para 5.2.3	
N. Conspicuity Marking	Per Dwg	SH-3D (SAR Only)	12197	
O. Abandon Chute/Rescue	Bottom of Fuselage	SH-3D (SAR Only)	35237	
P. Main Rotor Blades		N/A	35237	
Q. Tail Rotor Blades		N/A	36320	
R. Engine Exhaust Area	Aft Engine Nacelle	N/A	36081	

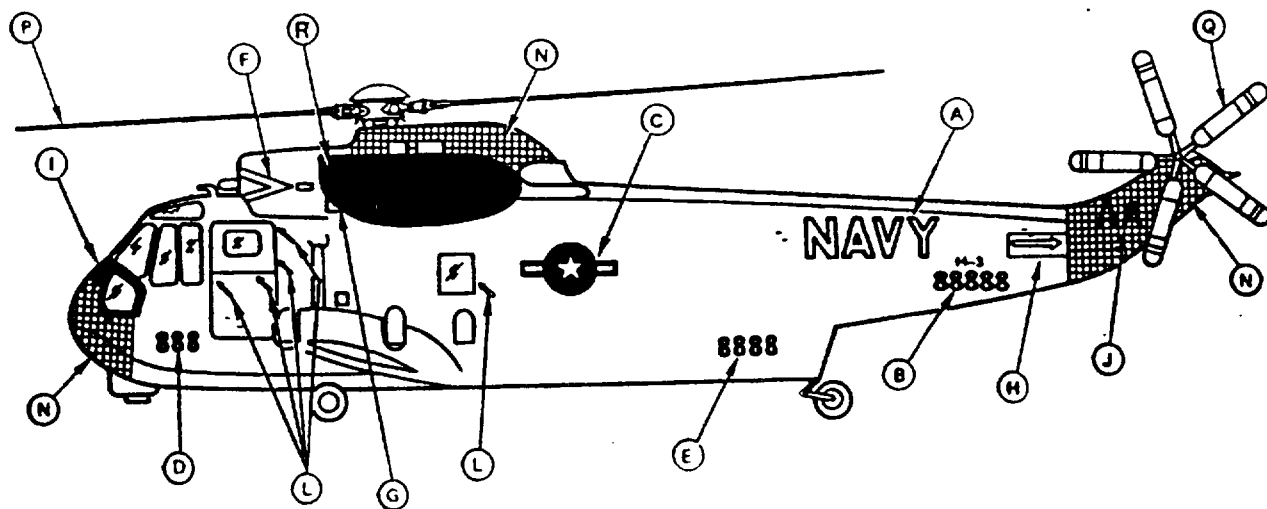


FIGURE C-52. SH-3D/H aircraft marking (tactical).

MIL-STD-2161A(AS)

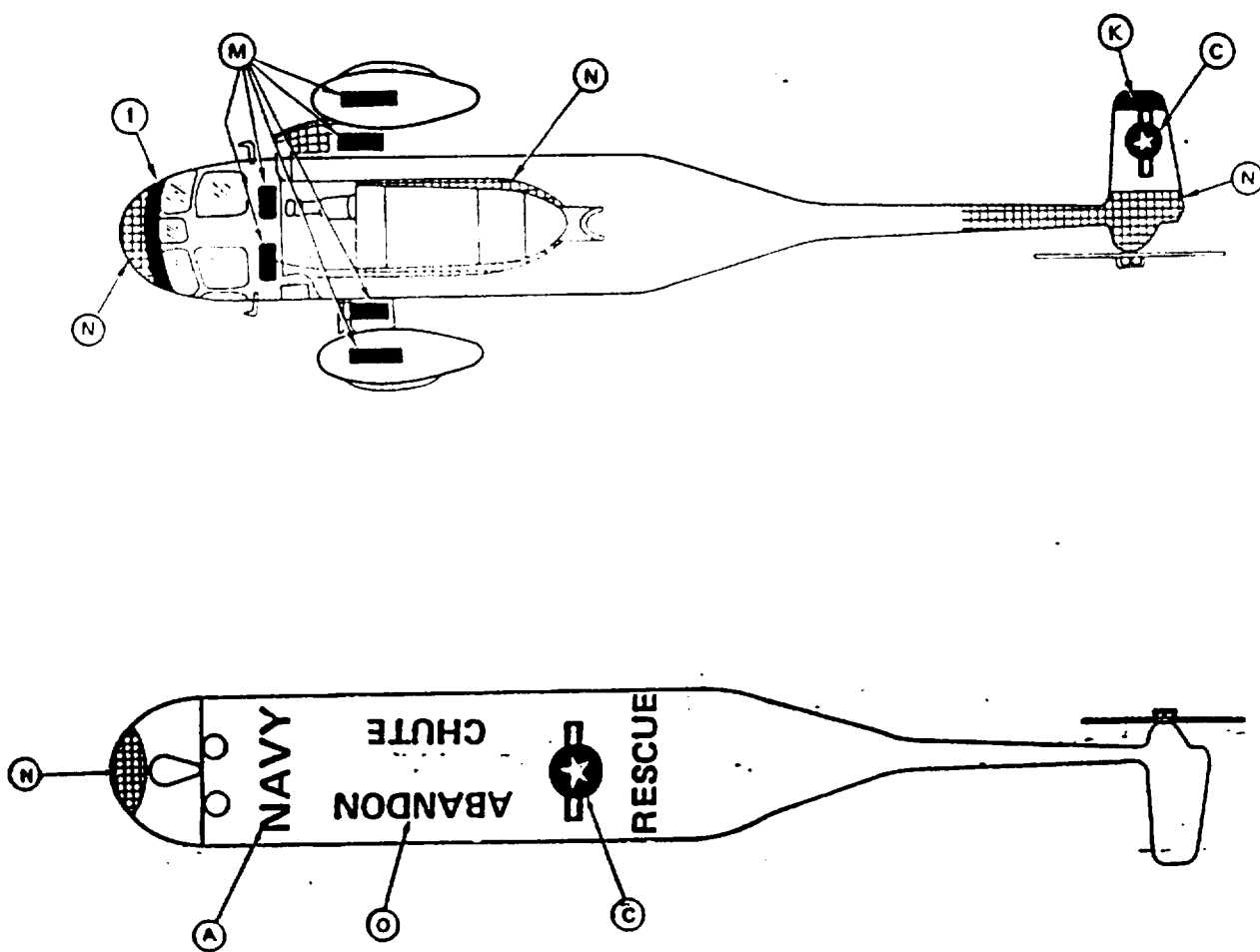


FIGURE C-52. SH-3D/H aircraft marking (tactical) - Continued.

MIL-STD-2161A(AS)

1. MARKING	2. LOCATION	3. SIZE	4. COLOR NO/CODE
A. NAVY	Aft Fuselage Lower L.H. Wing	12"/10" 24"/16"	17038
B. Model Designation, Acft BUNO	Aft Fuselage Aft Fuselage	2" 4"	17038
C. National Star	Fwd. Fuselage Lower R.H. Wing Upper L.H. Wing	20" 30" 30"	17925/11136/15044
D. Call Numbers	Vertical Stabilizer	12"	17038
E. Intake Warning	See Para. 5.2.2.10.1	See Para. 5.2.2.10.1	11136
F. Beware of Blast	Aft Fuselage	See Para. 5.2.2.10.2	17925/11136
G. Arresting Hook Warning	N/A	4" Alternating Stripes	17038/17925
H. Ejection Seat	Below Canopy Rail	See Para. 5.2.2.10.6.12	IAW Para. 5.2.3
I. Walkway	Wing Adjacent to Fuselage	N/A	37038
J. Conspicuity Markings	Per Drawing	See Para. 5.1.1.1	12197
K. Antiglare	Fwd. of Cockpit	N/A	17038
L. Unit Aircraft Numbers	Fwd. Fuselage Lower L.H. Wing Upper R.H. Wing	12" 16" 16"	17038
M. Unit Identifier	Vertical Stabilizer Lower L.H. Wing Upper L.H. Wing	20" 16"	17038

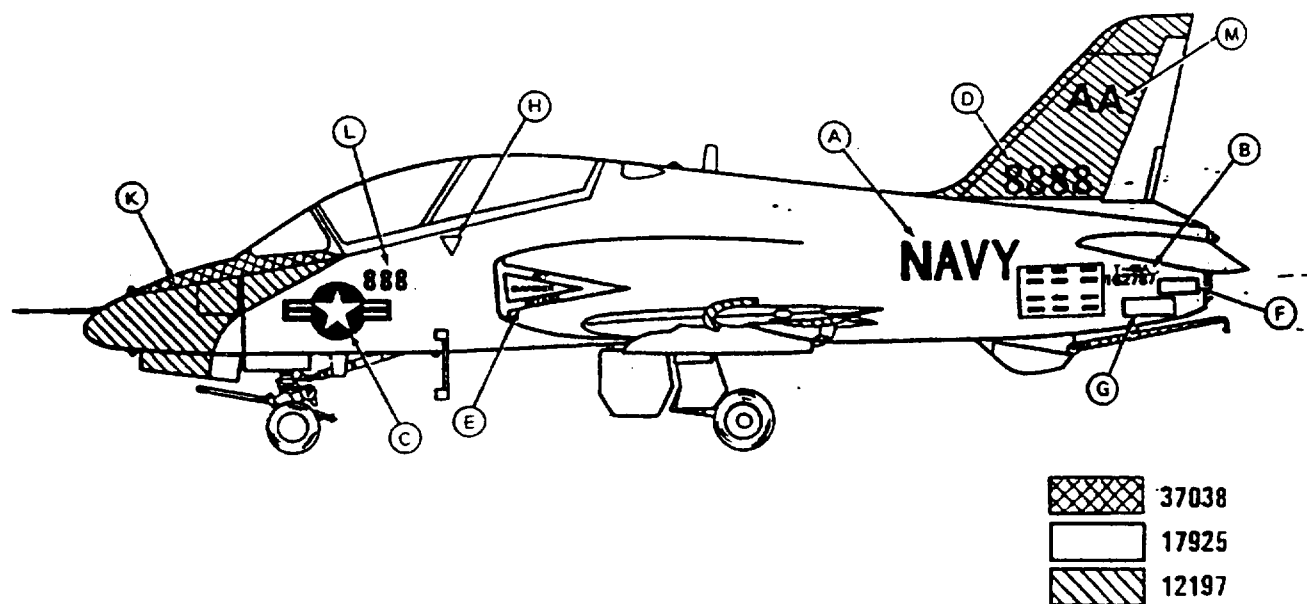


FIGURE C-53. T-45A aircraft marking (high visibility).

MIL-STD-2161A(AS)

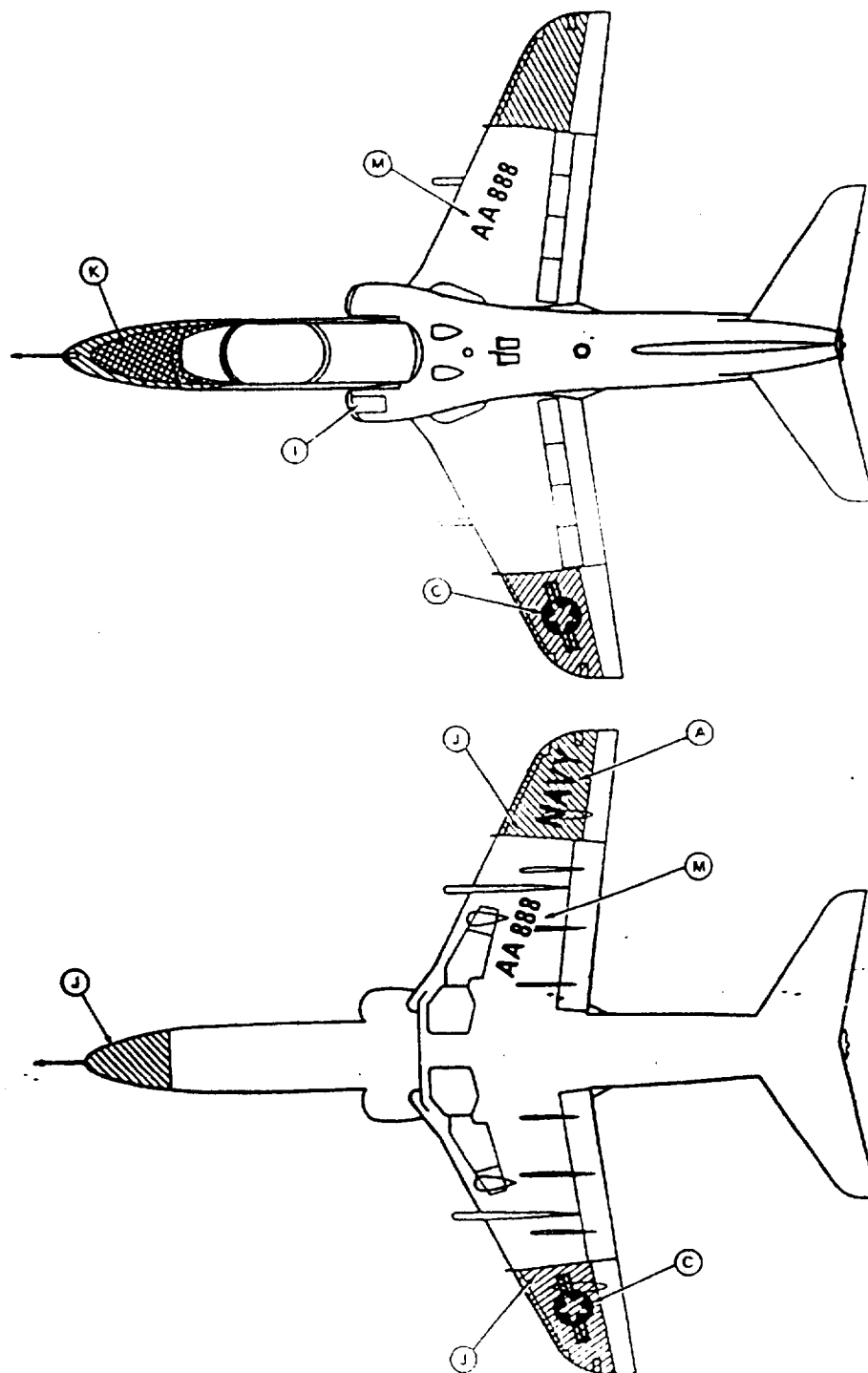


FIGURE C-53. T-45A aircraft marking (high visibility) - Continued.

MIL-STD-2161A(AS)

1. MARKING	2. LOCATION	3. SIZE	4. COLOR NO/CODE
A. NAVY	Tail Boom	24"	17925
B. Model Designation, Acft BUONO	Side Tail Boom	2" 4"	17925
C. National Star	Aft Fuselage Top Fuselage	20" 20"	17925/11136/15044
D. Intake Warning	Forward Intake	15"	11136/17925
E. Beware of Blast	Below Exhaust Exit	5"	11136/17925
F. Tail Rotor Warning	Tail Boom	33"	13538/17038/11136
G. Antislare	Nose Fwd. of Canopy	N/A	37038
H. Walkway	Top Fuselage	N/A	36231
I. Call Numbers	Aft Fuselage	12"	17925
J. Unit Aircraft Numbers	Fwd. Fuselage Tail Boom Mid	10" 10"	17925
K. Unit Identifier	Tail Boom	10"	17925
L. Rescue Arrow	Pilot Cockpit Door Copilot Cockpit Door	24" 18"	13538/17925
M. Sonobuoy Launch Door Marking	Center Left Fuselage	2" 2" 1"	11136 17925 17038
N. Main Rotor Blades		N/A	35237
O. Tail Rotor Blades		N/A	36320

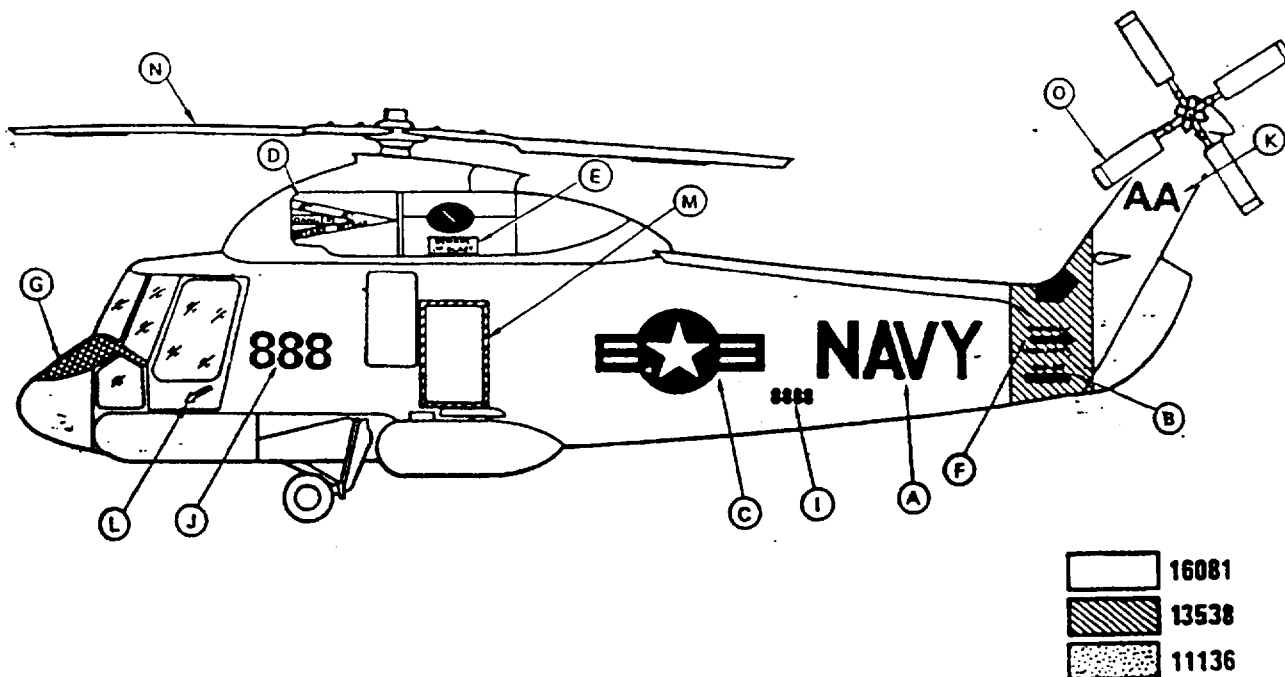


FIGURE C-54. UH-20 aircraft marking.

MIL-STD-2161A(AS)

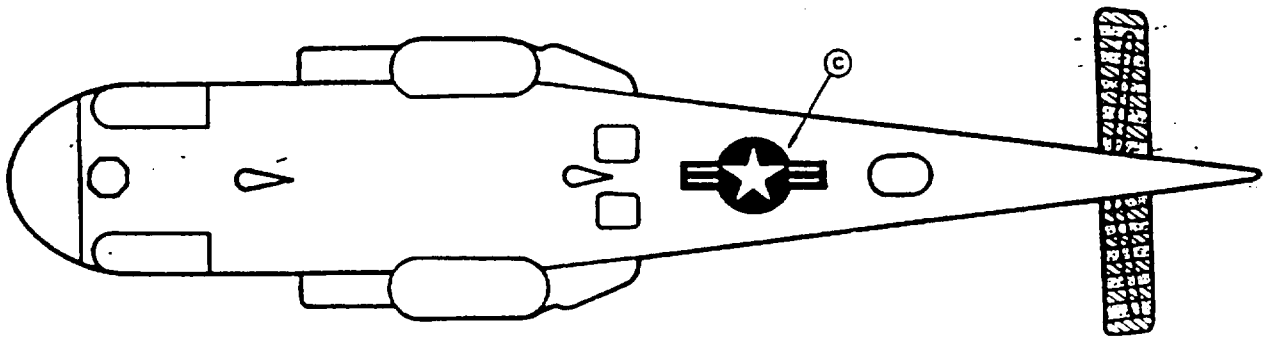
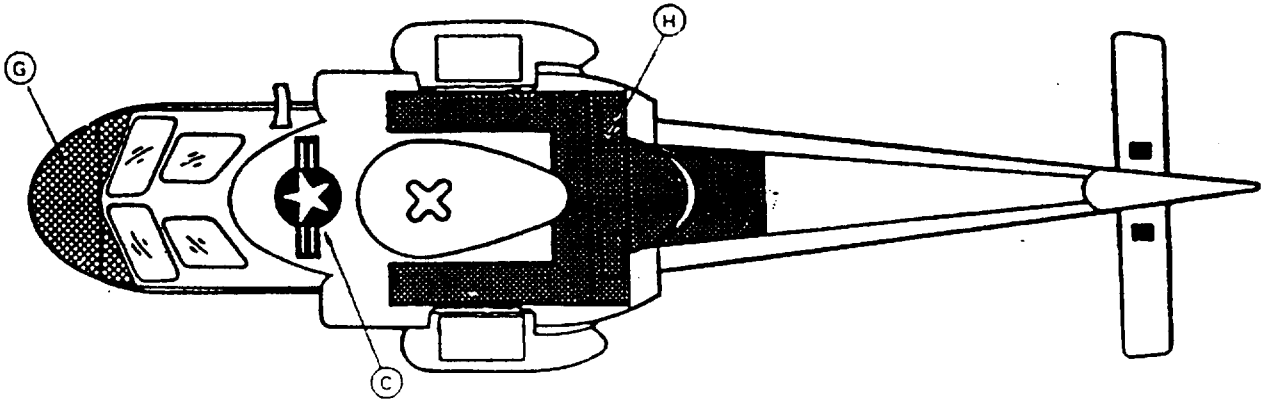


FIGURE C-54. UH-2D aircraft marking - Continued.

MIL-STD-2161A(AS)

APPENDIX D

SPECIAL PURPOSE AIRCRAFT MARKING

10. SCOPE

10.1 Scope. This Appendix illustrates the different paint schemes for special purpose aircraft including the presidential helicopter.

10.2 Use. This Appendix is a mandatory part of this standard. The information contained herein is intended for compliance.

20. APPLICABLE DOCUMENTS. This section is not applicable to this Appendix.

30. DEFINITIONS

30.1 Definitions. For purposes of this Appendix, the definitions of this standard shall apply.

40. GENERAL REQUIREMENTS

40.1 Aircraft paint schemes. The following figures illustrate aircraft marking for special purpose aircraft.

MIL-STD-2161A(AS)

1. MARKING	2. LOCATION	3. SIZE	4. COLOR NO/CODE
A. NAVY	Aft Fuse	16"	17038
B. Model Designation, A/cft BUNO	Aft Fuselage Under Horizontal Stabilizer	2" 4"	17038
C. National Star	Aft Fuselage Upper L.H. Wing Lower R.H. Wing	40" 30" 30"	11136 15044 17925
D. Call Numbers	Vertical Stabilizer	12"	17038
E. Propeller Tips	N/A	4" / 4" / 4"	17925/11136/17925
F. Antiglare	Upper 1/2 Nose and Inside Upper 1/2 Eng Cowl	N/A	37038
G. Walkway	Per Drawing		37038
H. Propeller Warning Band	Fwd. Fuselage	3"	11136
I. Flag	Vertical Stabilizer	26 X 46	11136/15044/17925
J. Unit Aircraft Numbers	Nose	16"	17038
K. Unit Identifier	Vertical Stabilizer	30"	17038

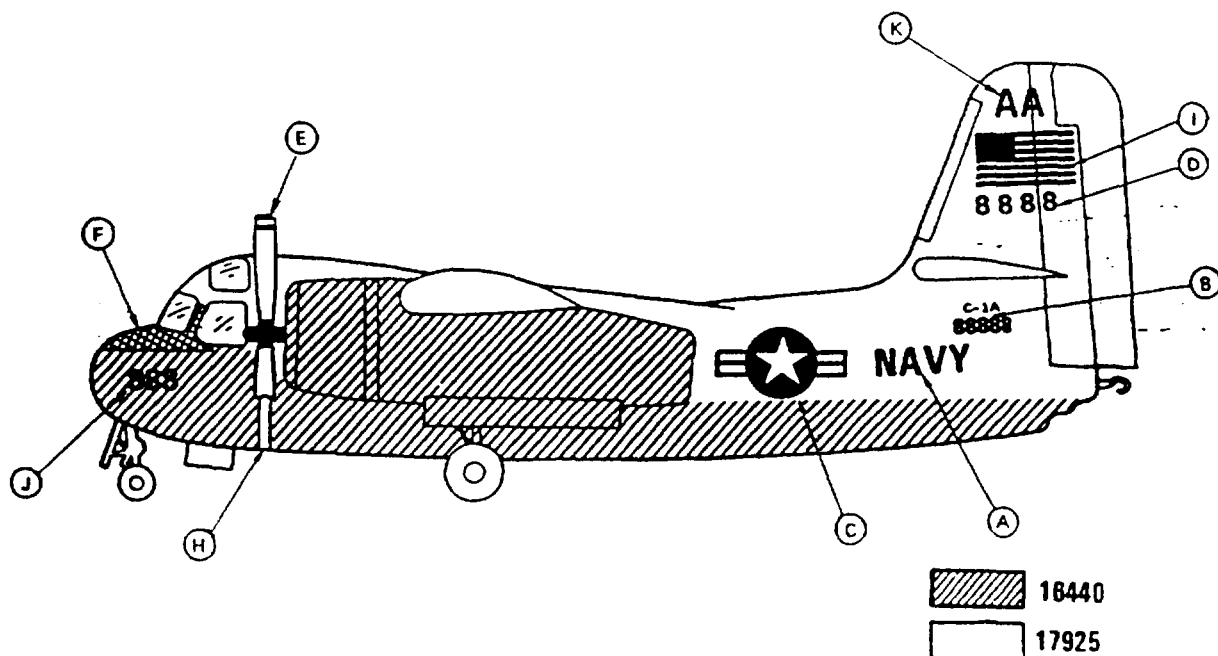


FIGURE D-1. C-1A aircraft marking.

MIL-STD-2161A(AS)

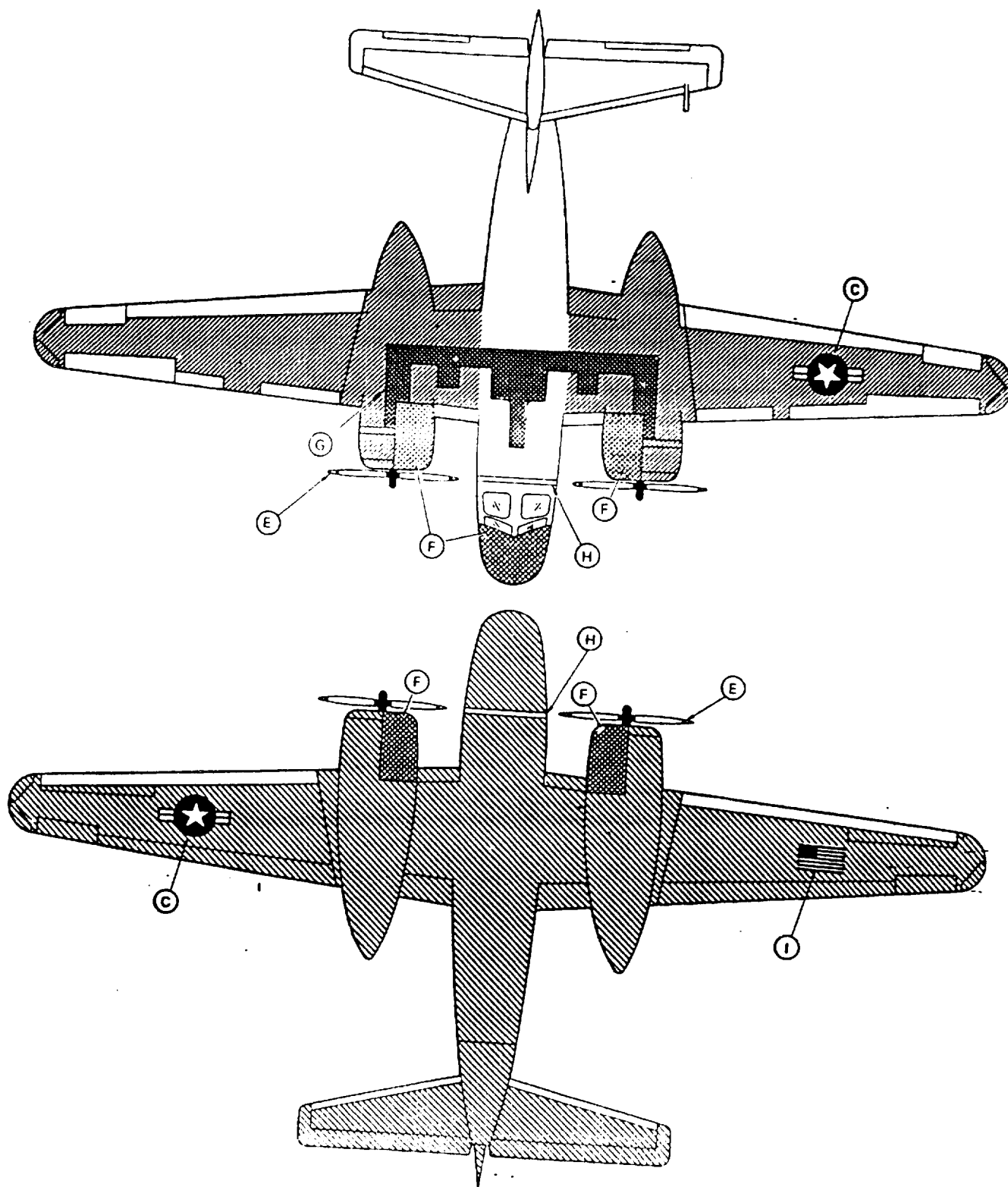


FIGURE D-1. C-1A aircraft marking - Continued.

MIL-STD-2161A(AS)

1. MARKING	2. LOCATION	3. SIZE	4. COLOR NO/CODE
A. UNITED STATES NAVY	Fuselage	16"	17038
B. Model Designation, Acft BUNO	Aft Fuselage Under Horizontal Stabilizer	2" 4"	17038
C. National Star	Aft Fuselage Upper L.H. Wing Lower R.H. Wing	40" 40" WG	11136 15044 17925
D. Call Numbers	Vertical Stabilizer	16"	17038
E. Propeller Tips	N/A	4"/4"/4"	11136/17925/ 15102
F. Antiglare	Fwd. of Cockpit	N/A	37038
G. Unit Identifier	R.H. and L.H. Fwd. Fuselage	9"	17038
H. Propeller Warning Band	Lower Fuselage Propeller Plane	3"	11136
I. Navy	Lower L.H. Wing	30"	17038

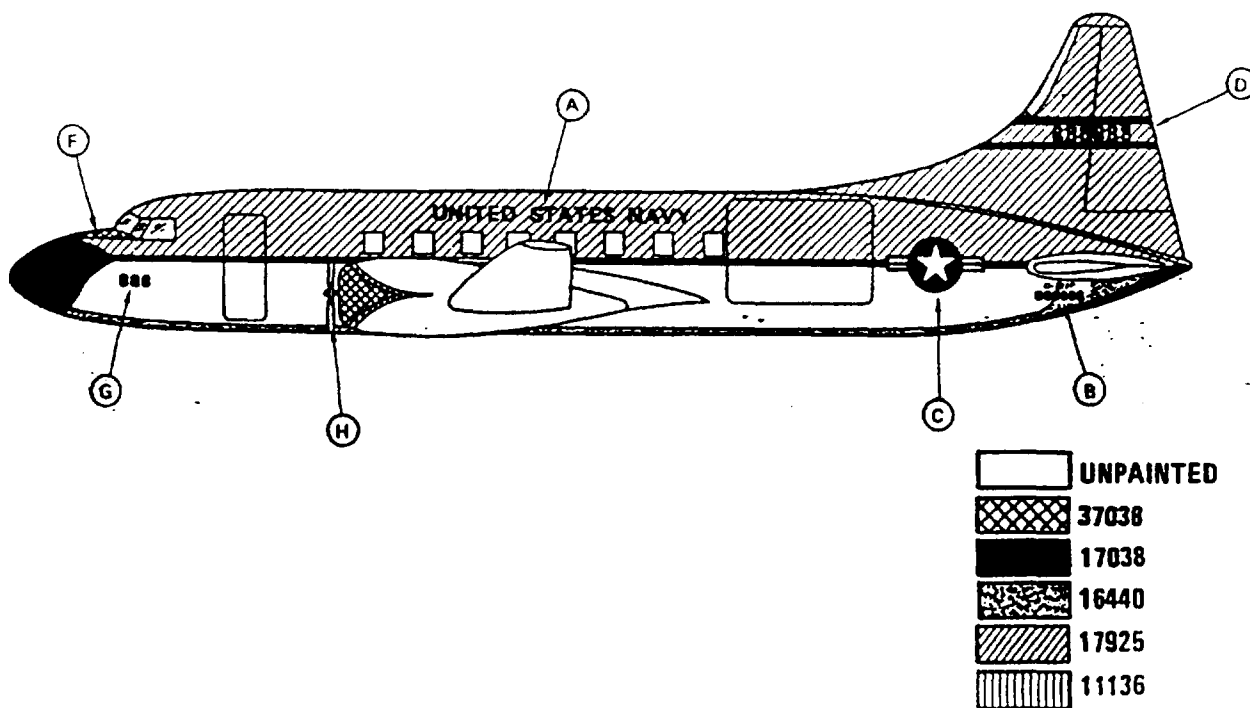


FIGURE D-2. C-131 aircraft marking (executive transport).

MIL-STD-2161A(AS)

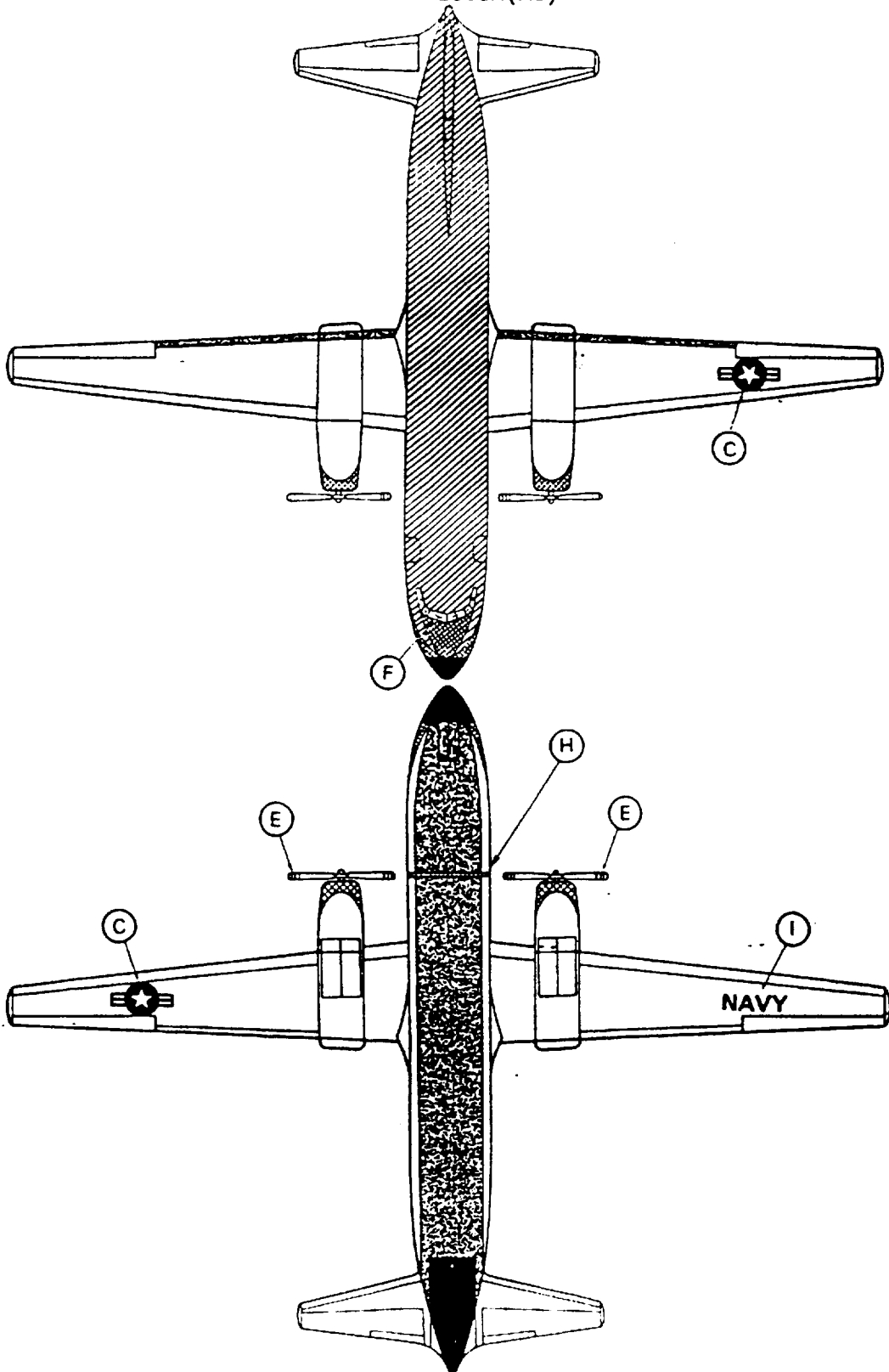


FIGURE D-2. C-131 aircraft marking (executive transport) - Continued.

MIL-STD-2161A(AS)

1. MARKING	2. LOCATION	3. SIZE	4. COLOR NO/CODE
A. UNITED STATES NAVY NAVY	Center Fuselage Lower L.H. Wing Upper R.H. Wing	12" 20"	17038
B. Model Designation, Actt BUNO		2" 4"	17038
C. National Star	Engine Nacelle, Both Sides, Upper L.H. & Lower R.H. Wing	13"	11136/15044/17925
D. U.S. Flag	Vertical Tail	4 1/2"	11136/15044/17925
E. Call Numbers	Lower Vertical Stabilizer Fwd. Fuselage	12"	17038
F. Intake Chevrons	Fwd. Engine Nacelle		11136
G. Beware of Blast	Aft Engine Nacelle		11136
H. Accent Stripe Below	Below Lower Window Line	1/4 Border 1 3/4	Gold Bronze 15044
I. Anti Glare			37038
J. Walkway			37038
K. Unit Identifier	Fwd. Fuselage	6"	17038

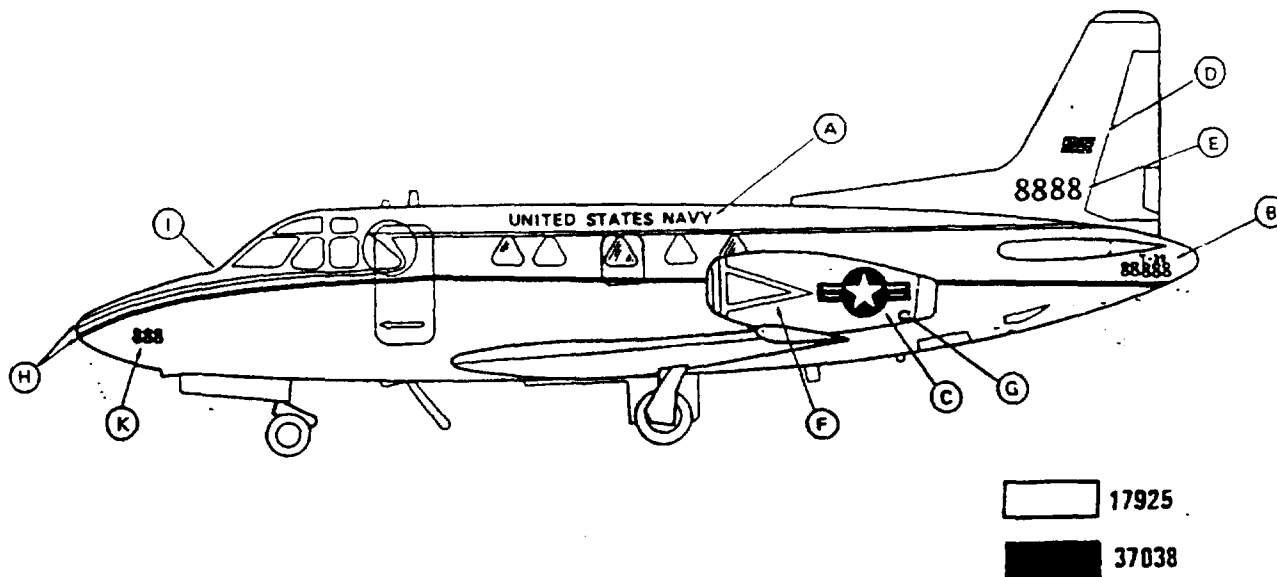


FIGURE D-3. CT-39E/G aircraft marking (Navy).

MIL-STD-2161A(AS)

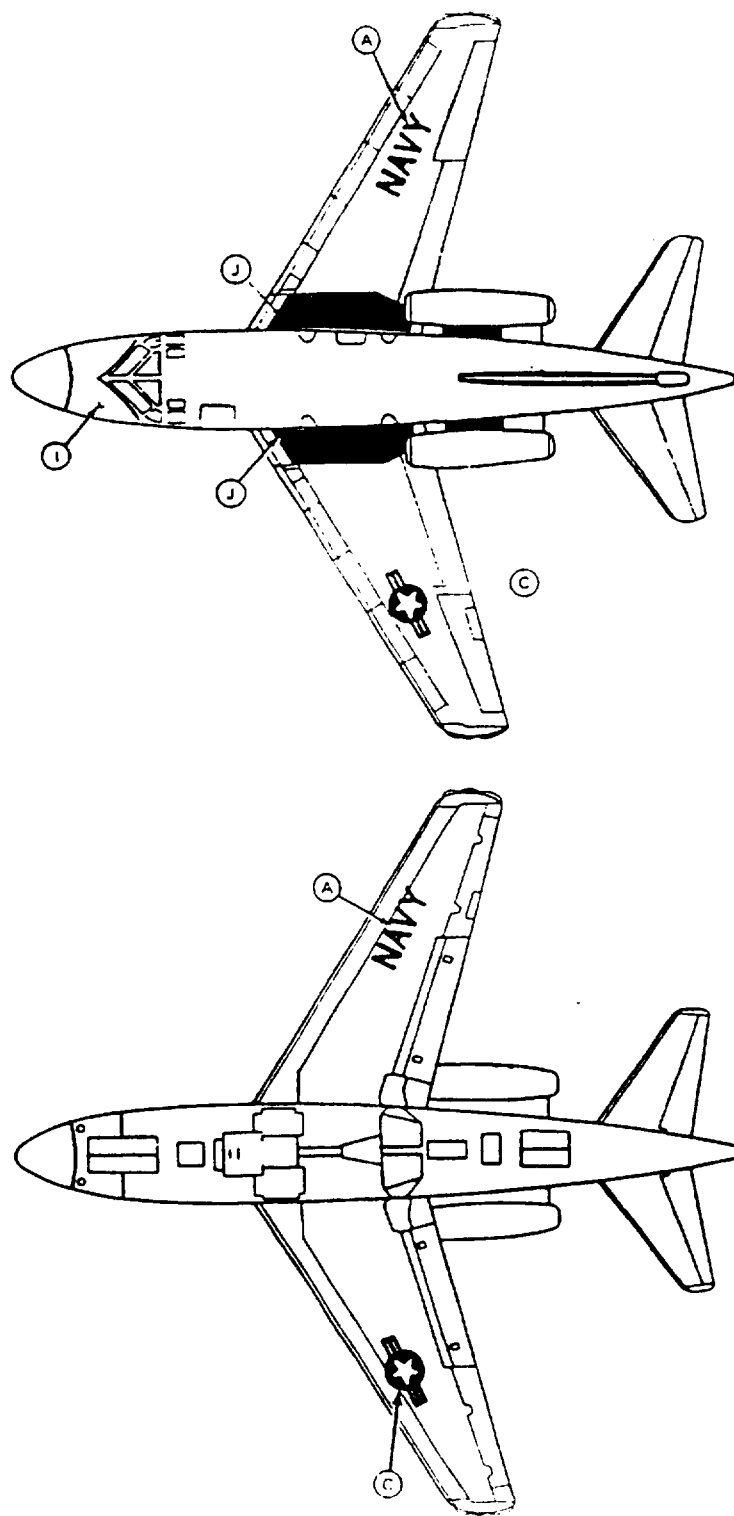


FIGURE D-3. CT-39E/G aircraft marking (Navy) - Continued.

MIL-STD-2161A(AS)

1. MARKING	2. LOCATION	3. SIZE	4. COLOR NO/CODE
A. UNITED STATES MARINES	Center Fuselage Lower L.H. Wing Upper R.H. Wing	12" 20"	17038
B. Model Designation, Actt BUNO		2" 4"	17038
C. National Star	Engine Nacelle, Both Sides, Upper L.H. & Lower R.H. Wing	13"	11136/15044/17925
D. U.S. Flag	Vertical Tail	4 1/2"	11136/15044/17925
E. Call Numbers	Lower Vertical Stabilizer	12"	17038
F. Intake Chevrons	Fwd. Engine Nacelle		11136
G. Beware of Blast	Aft Engine Nacelle		11136
H. Accent Stripe Below	Below Lower Window Line	1/4 Border 1 3/4	Gold Bronze 11136
I. Anti Glare	Fwd. of Windscreen	N/A	37038
J. Walkway			37038
K. Unit Identifier	Fwd. Fuselage	6"	17038

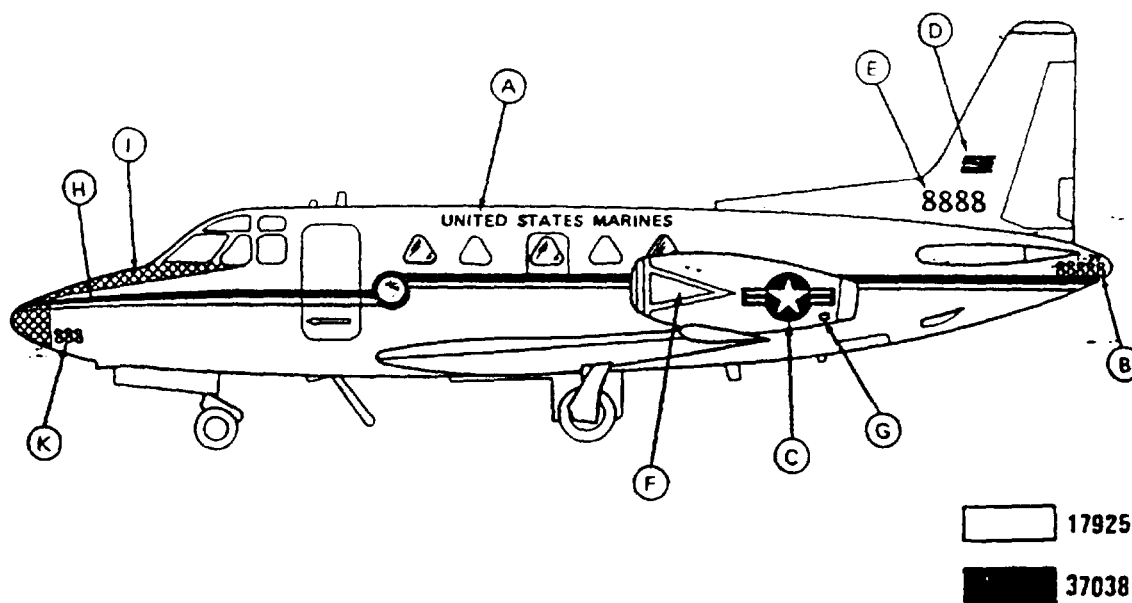


FIGURE D-4. CT-39G aircraft marking (Marine).

MIL-STD-2161A(AS)

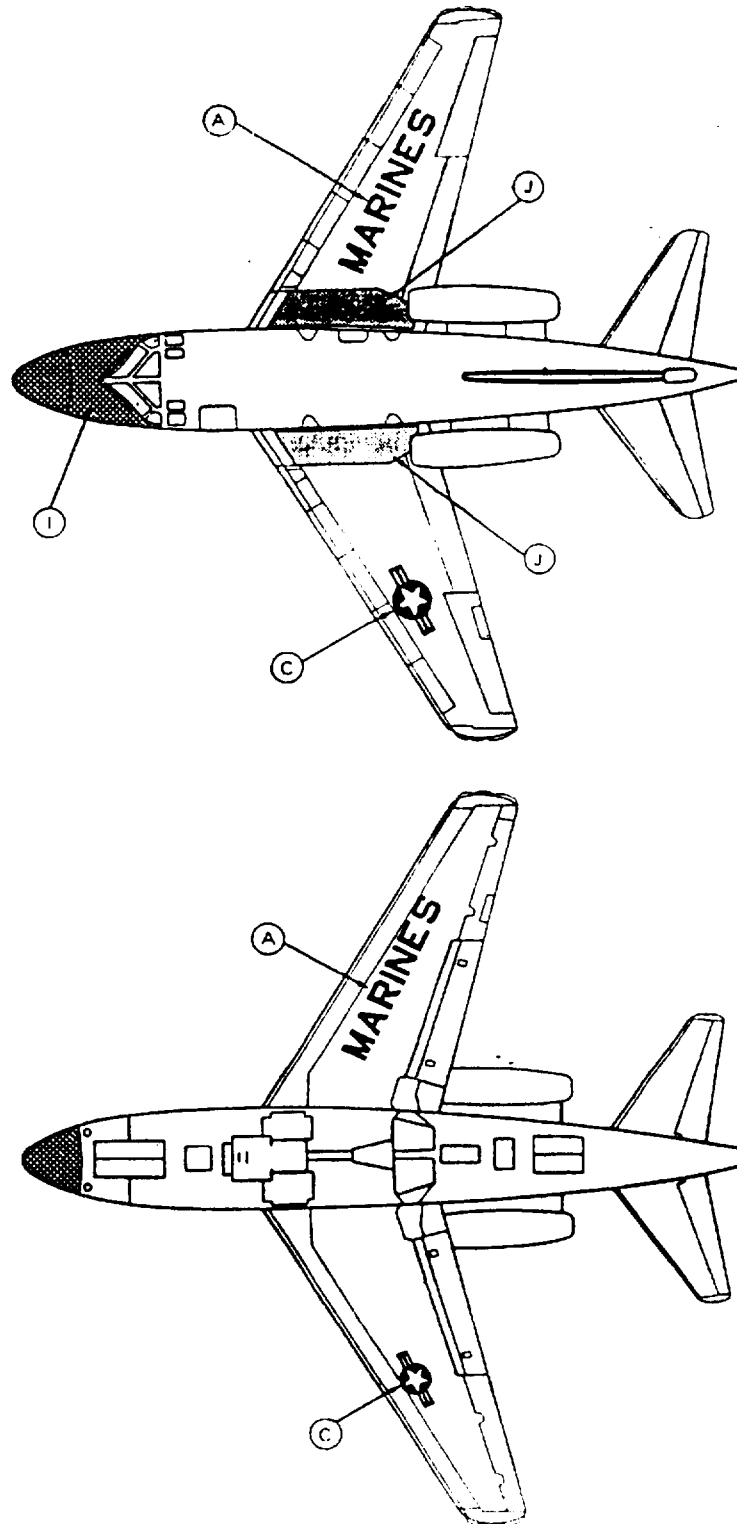


FIGURE D-4. CT-39G aircraft marking (Marine) - Continued.

MIL-STD-2161A(AS)

1. MARKING	2. LOCATION	3. SIZE	4. COLOR NO/CODE
A. UNITED STATES NAVY	Center Fuselage Lower L.H. Wing	12" 20"	15044
B. Model Designation, A/cft BUONO	Aft Fuselage	2" 8"	17038
C. National Star	Fuselage Side Upper L.H. Wing Lower R.H. Wing	20" 30" 30"	11136 15044 17925
D. UNITED STATES NAVAL ATTACHÉ NAVAL ATTACHÉ DES ETATS LORS EN FRANCE	Fwd. Fuselage	2"	17038
E. Call Numbers	Lower Vertical Stabilizer	12"	17038
F. Intake Warning	Fwd. Engine Nacelle		11136
G. Beware of Blast	Aft Engine Nacelle		11136
H. Accent Stripe	Below Lower Window Line	1/4 Border 1 3/4	Gold Bronze 11136
I. Walkway	Wings and Engine Mounts Adjacent to Fuselage		37038
J. Bare Metal Finish	Engine Inlet and Exhaust Nacelles	N/A	N/A
K. Antiglare	Fwd. Nose Section	N/A	37038
L. Flag	Vertical Tail Lower L. H. Wing	See Para. 5.2.7	IAW Para. 5.2.3
M. Rescue Arrow	Fwd. Fuselage	24"	17038/13538

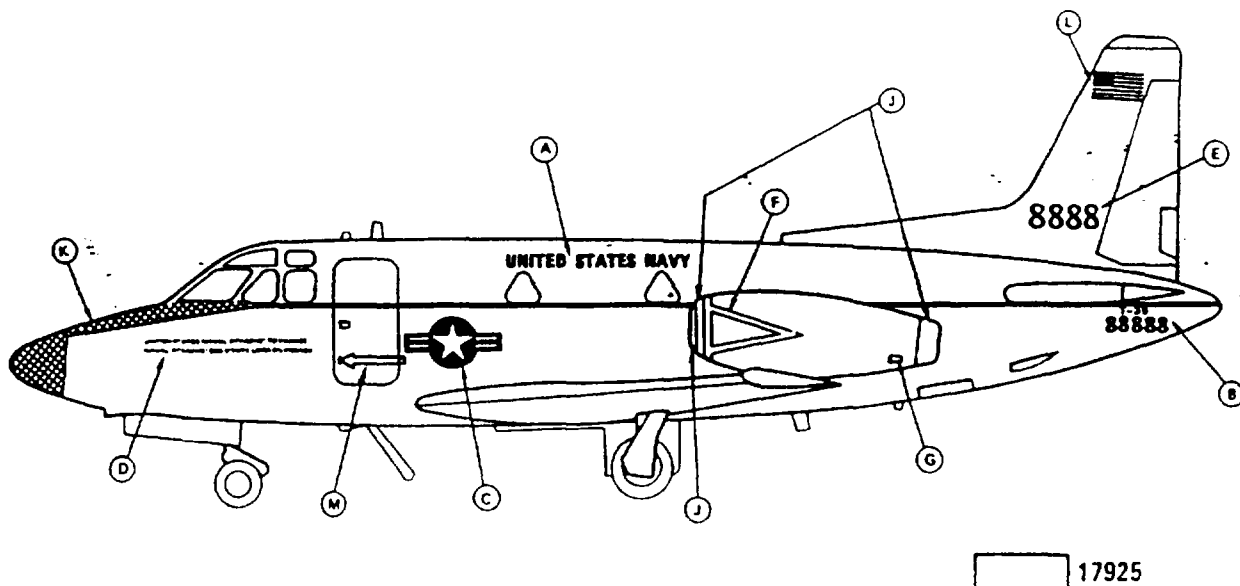


FIGURE D-5. T-39 aircraft marking (naval attache).

MIL-STD-2161A(AS)

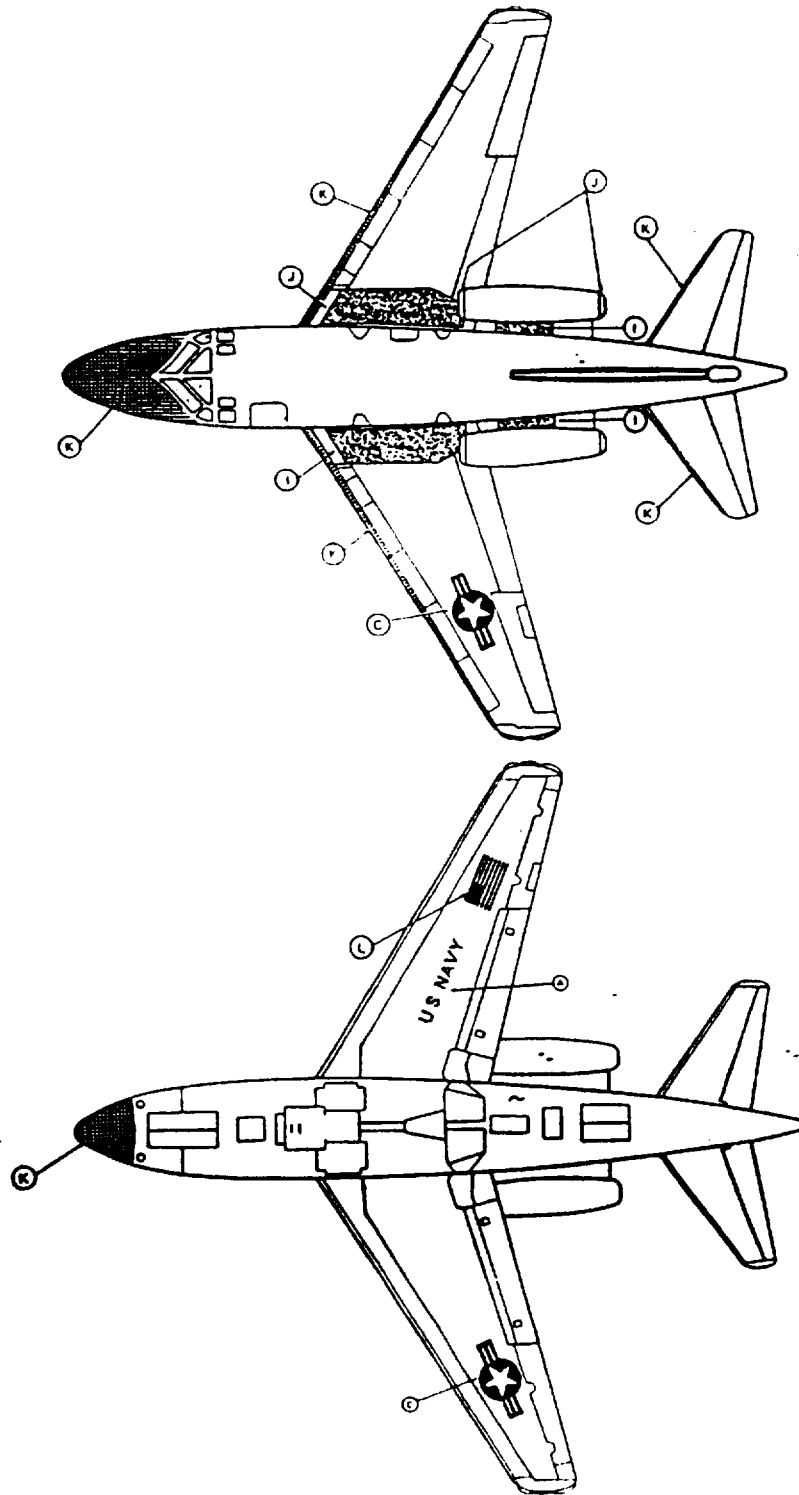
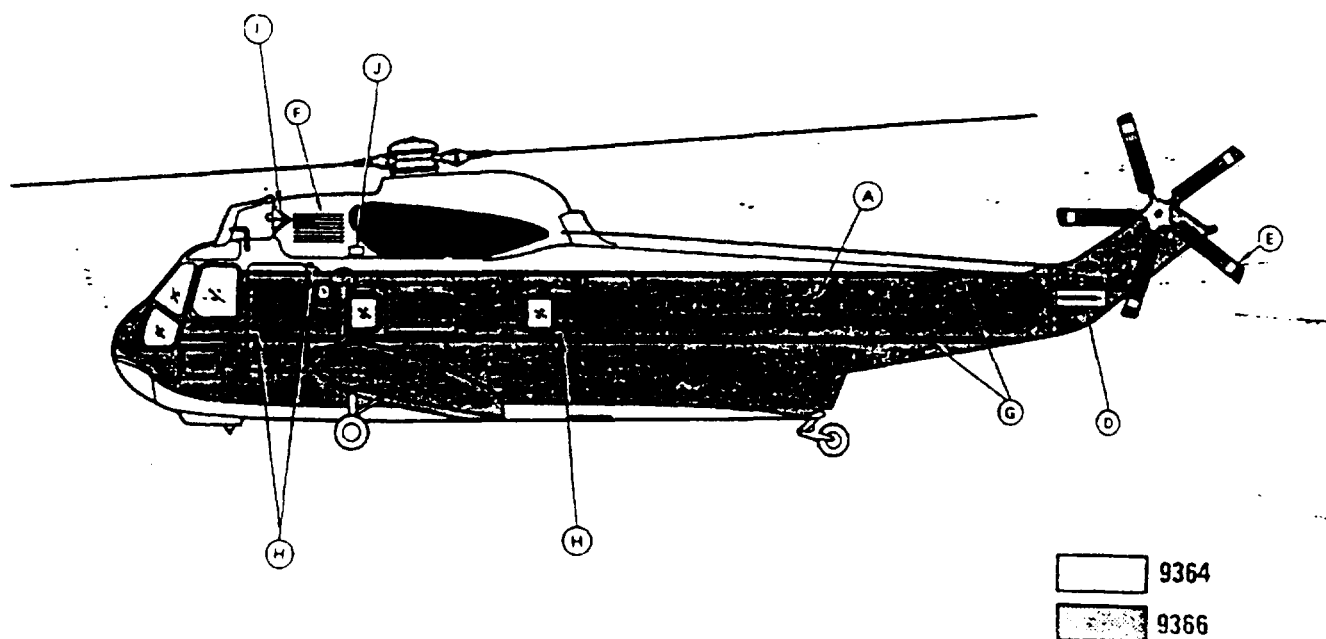


FIGURE D-5. T-39 aircraft marking (naval attache) - Continued.

MIL-STD-2161A(AS)

1. MARKING	2. LOCATION	3. SIZE	4. COLOR NO/CODE
A. UNITED STATES OF AMERICA	Fuselage Tail Boom	8"	17038
B. National Star	Center Lower Fuselage Upper Tail Horizontal	30" 25"	11136 15044 17925
C. Wheel Wells	N/A	N/A	Alaska White
D. Tail Rotor Warning	Aft Fuselage	35"	11136/13538
E. Tail Rotor	N/A	4"/4"/4"	11136/17925 11136/17038
F. Flag	Forward Engine Nacelle	18 X 34"	11136 15044 17925
G. Accent Strips	Per Drawing	4"	9366/9364
H. Rescue Arrow	Fwd. Fuselage	24"	17038/13538
I. Intake Warning	Fwd. Engine Nacelle	16"	17925/11136
J. Beware of Blast	Engine Exhaust Nacelle	22"	17925/11136
K. Walkway	Top Fwd. Fuselage and Landing Gear Housing	N/A	17038

FIGURE D-6. VH-3D presidential helicopter marking.

MIL-STD-2161A(AS)

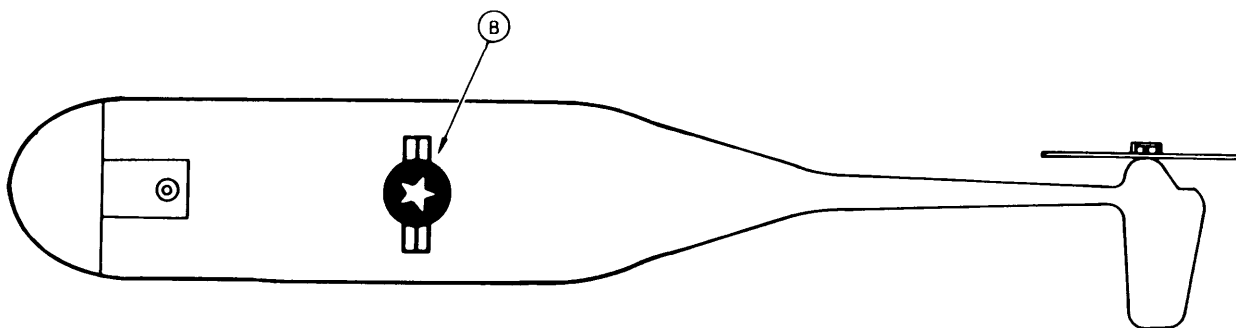
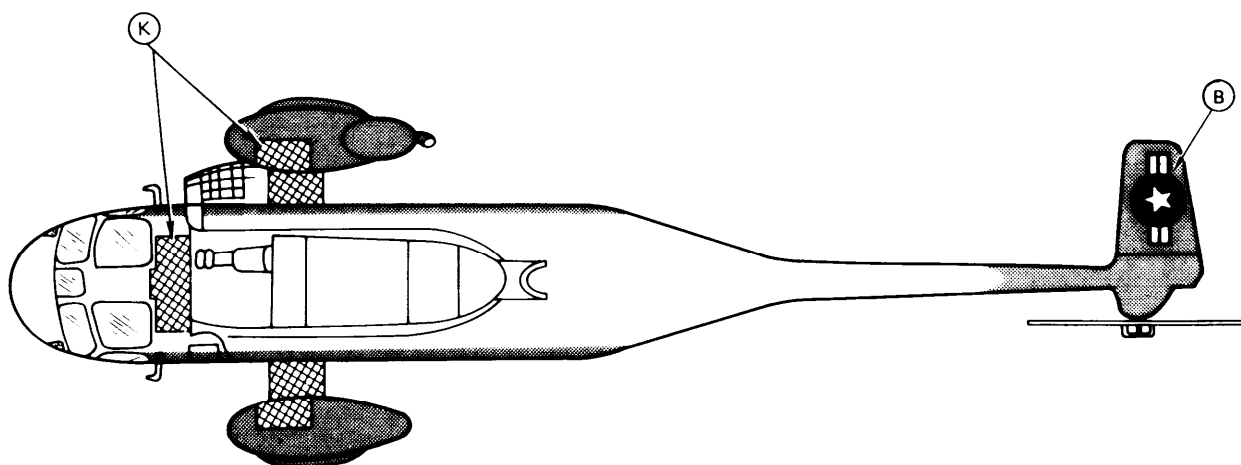


FIGURE D-6. VH-3D presidential helicopter marking - Continued.

MIL-STD-2161A(AS)

1. MARKING	2. LOCATION	3. SIZE	4. COLOR NO/CODE
A. UNITED STATES NAVY	Fwd. Fuselage	16"	17038
B. Model Designation, Acft BUNO	Aft Fuselage	2" 4"	17038
C. National Star	Engine Pod Upper L.H. Wing Lower R.H. Wing	28" 34" 34"	11136 15044 17925
D. Call Numbers	Vertical Stabilizer	16"	17038
E. Navy	Upper R.H. Wing Lower L. H. Wing	36"	17038
F. Bare Metal	Wing Leading Edge Cap (Slats); Engine Tail Pipe; Forward Portion Flap Hinge Fairings; Leading Edge, Engine Pylons; Engine Fwd. Nacelles; & Rub Area, Horizontal Stabilizer	Per Drawing	N/A
G. Gold Stripe	Center Fuselage	6"	Gold
H. Blue Stripe	Center Fuselage	12"	15044
I. Unit Aircraft Numbers	Wings Fwd. Fuselage	16" 16"	17038
J. Antiglare	Fwd. of Cockpit	N/A	37038
K. Unit Identifier	Vertical Fin Upper Right Wing Lower Left Wing	36" 16" 16"	17038 17038 17038
L. Logo (Optional)	See Para. 5.2.1	See Para. 5.2.1	
M. Flag	Upper Vertical Fin	26" x 46"	11136 15044 17925
N. Erosion Boot	Nose	Per Drawing	17038
O. Activity Name	Nose	3"	17038

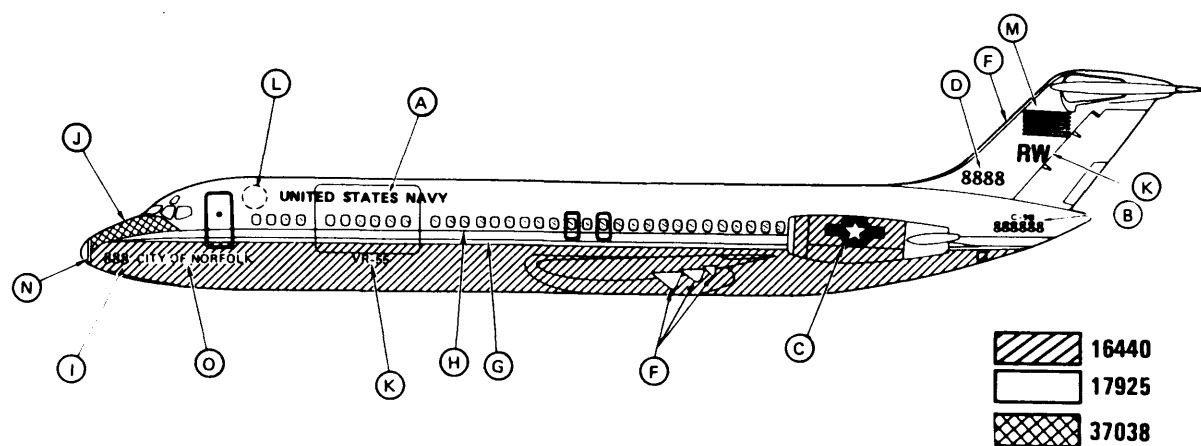


FIGURE D-7. C-9B aircraft marking (Navy).

MIL-STD-2161A(AS)

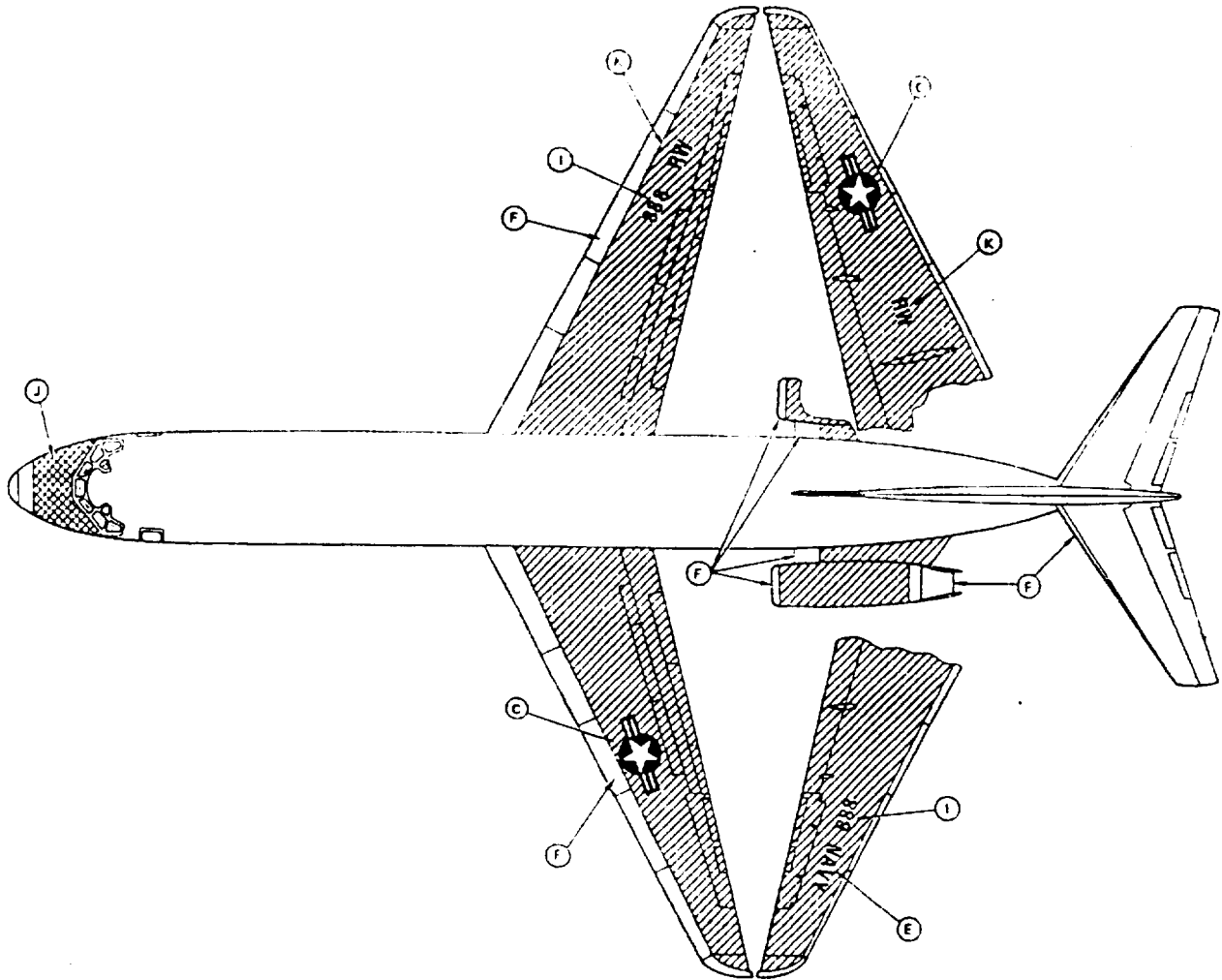


FIGURE D-7. C-9B aircraft marking (Navy) - Continued.

MIL-STD-2161A(AS)

1. MARKING	2. LOCATION	3. SIZE	4. COLOR NO/CODE
A. UNITED STATES MARINES	Fwd. Fuselage	12"	17038
B. Model Designation, Act BUNO	Aft Fuselage	4" 2"	17038
C. National Star	Engine Pod Upper L.H. Wing Lower R.H. Wing	25" 30" 30"	11136 17925 15044
D. Call Numbers	Vertical Stabilizer	10"	17038
E. Marines	Upper R.H. Wing Lower L.H. Wing	30"	17038
F. Bare Metal	Engine Inlet Nacelle Engine Exhaust Cowling Thrust Reversers Passenger Windows Borders	N/A	N/A
G. Red Stripe	Center Fuselage	6"	11136
H. Yellow Stripe	Center Fuselage	12"	13538
I. Unit Aircraft Numbers	Wing Fwd. Fuselage	12"	17038
J. Antiglare	Fwd. of Cockpit	N/A	37038
K. Unit Identifier	Fwd. Fuselage	6"	17038
L. Logo (Optional)	Center Fuselage	34"	IAW Squadron Policy
M. Flag	Upper Vertical Stabilizer	25" x 48"	11136 17925 15044
N. Erosion Boot	Nose	Per Drawing	17038

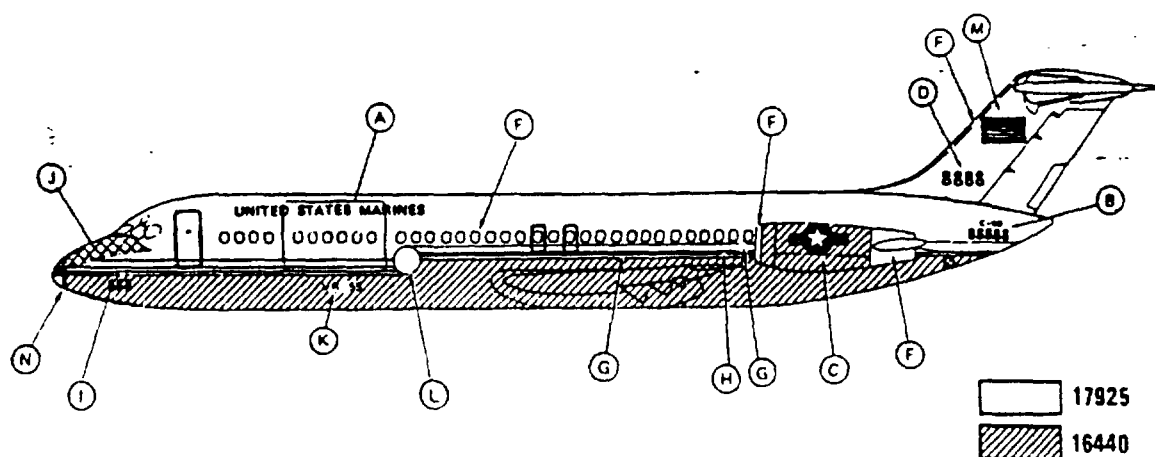


FIGURE D-8. C-9B aircraft marking (Marine).

MIL-STD-2161A(AS)

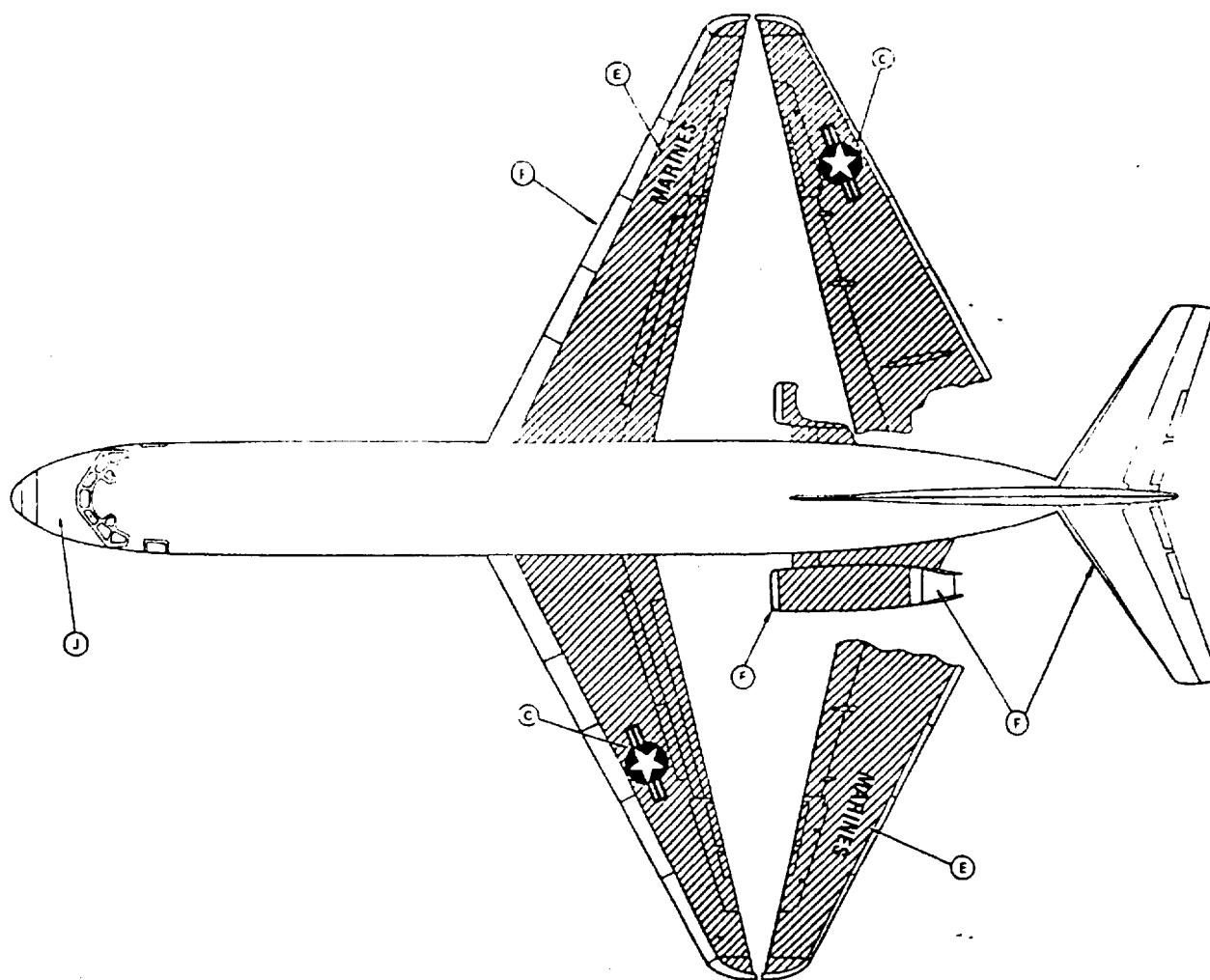
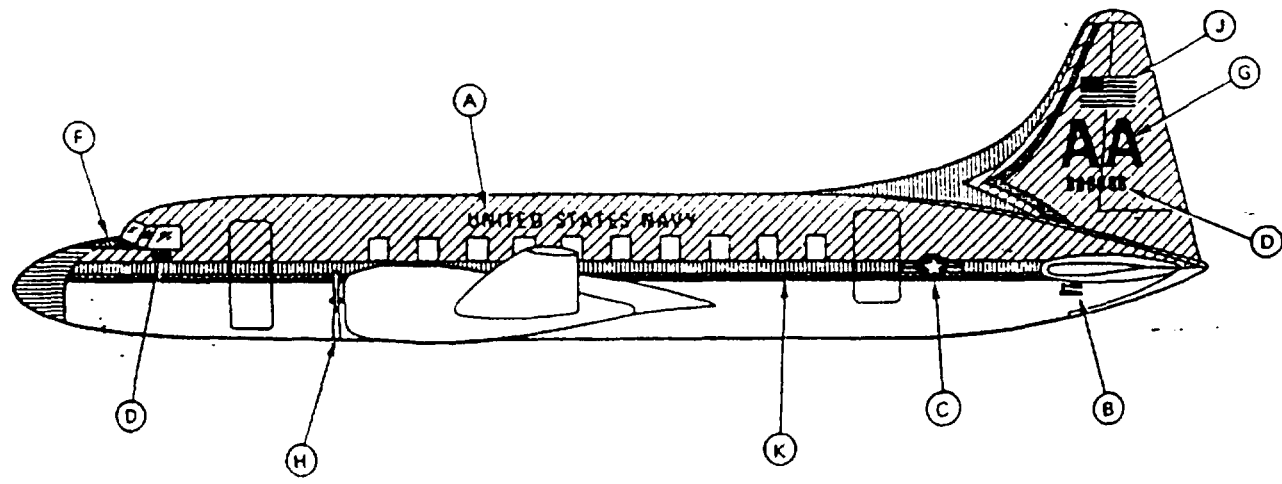


FIGURE D-8. C-9B aircraft marking (Marine) - Continued.

MIL-STD-2161A(AS)

1. MARKING	2. LOCATION	3. SIZE	4. COLOR NO/CODE
A. UNITED STATES NAVY	Fuselage	16"	17038
B. Model Designation, Aft BUINO	Aft Fuselage Under Horizontal Stabilizer	2" 4"	17038
C. National Star	Aft Fuselage Upper L.H. Wing Lower R.H. Wing	30" 40"	11136 15044 17925
D. Call Numbers	Fwd. Fuselage Vertical Stabilizer Upper R.H. & Lower L.H. Wing	8" 12" 30"	17038
E. Propeller Tips	N/A	4"/4"/4"	11136/17925/15102
F. Antiglare	Fwd. of Cockpit	N/A	37038
G. Unit Identifier	Vertical Stabilizer Upper & Lower R.H. Wing	30" Upper 30" Lower 16"	17038
H. Propeller Warning Band	Lower Fuselage Propeller Plane		11136
I. Navy	Lower L.H. Wing	30"	17038
J. U.S. Flag	Upper Vertical Stabilizer	21" x 40"	
K. Stripes	Fuselage	Upper 7" Middle 4" Lower 1"	15044 Imron 44469UH 17038









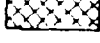
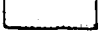
	UNPAINTED		17038
	16440		15044
	17925		11136
	37038		IMRON 44469UH

FIGURE D-9. C-131H aircraft marking.

MIL-STD-2161A(AS)

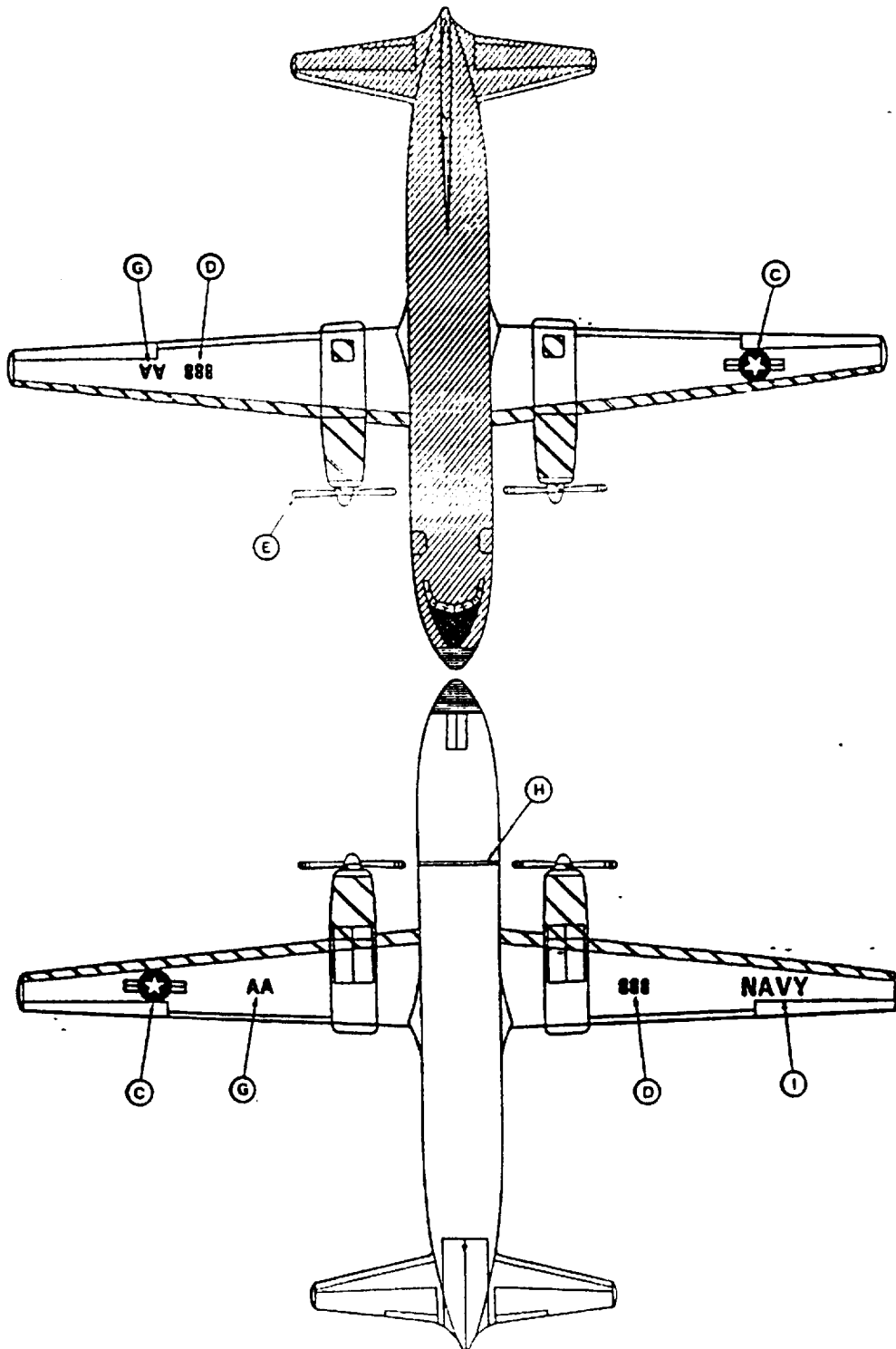


FIGURE D-9. C-131H aircraft marking - Continued.

MIL-STD-2161A(AS)

1. MARKING	2. LOCATION	3. SIZE	4. COLOR NO/CODE
A. U.S. NAVY	Lower R.H. Wing Lower L.H. Wing	24"	11136
B. Model Designation, Acrft BUNO	Aft Fuselage	2" 4"	11136
C. National Star	Aft Fuselage Lower L.H. Wing Upper R.H. Wing	25" 25" 25"	17925/11136/15044
D. Propeller Tips	Front Rear	3"/6"/3" 4"	17925/11136/17925 13538
E. Antiglare	Aft Sides of Propeller	N/A	37038
F. Walkway	Per Drawing	N/A	36440
G. Fly Navy	Vertical Stabilizer (Both Sides)	8"	11136
H. Accent Stripe	Fuselage Sides, Top of Wings & Top & Bottom of Horizontal Stabilizer	2"	11136
I. "Navy Wings"	Fwd. Fuselage	36"	17038/Gold

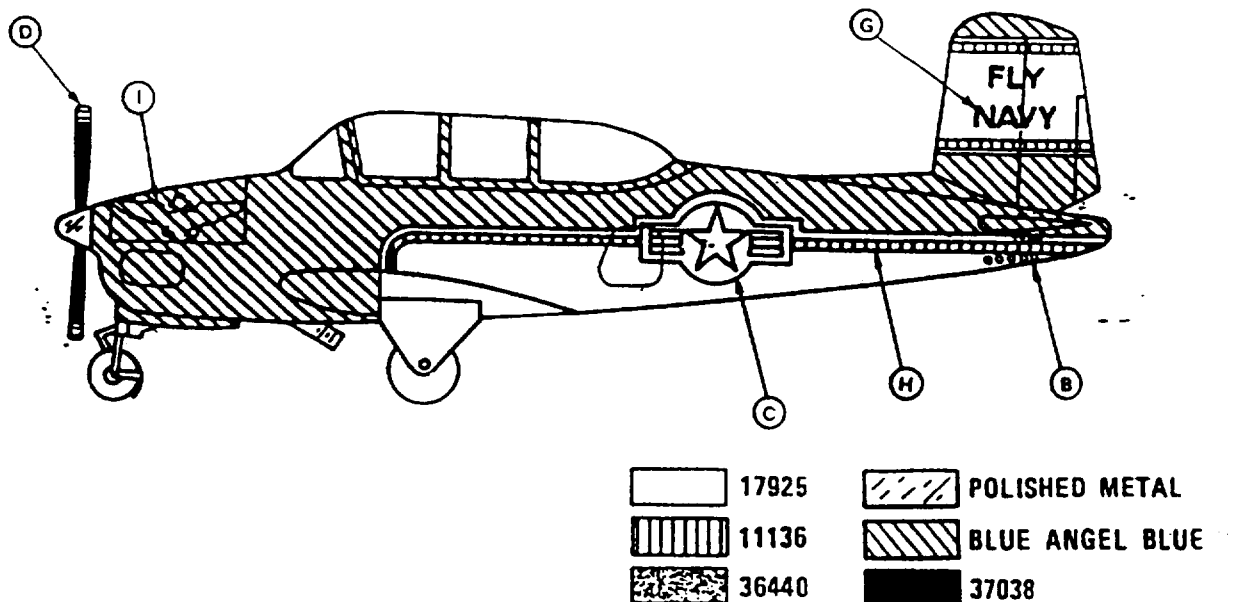


FIGURE D-10. T-34B aircraft marking (high visibility).

MIL-STD-2161A(AS)

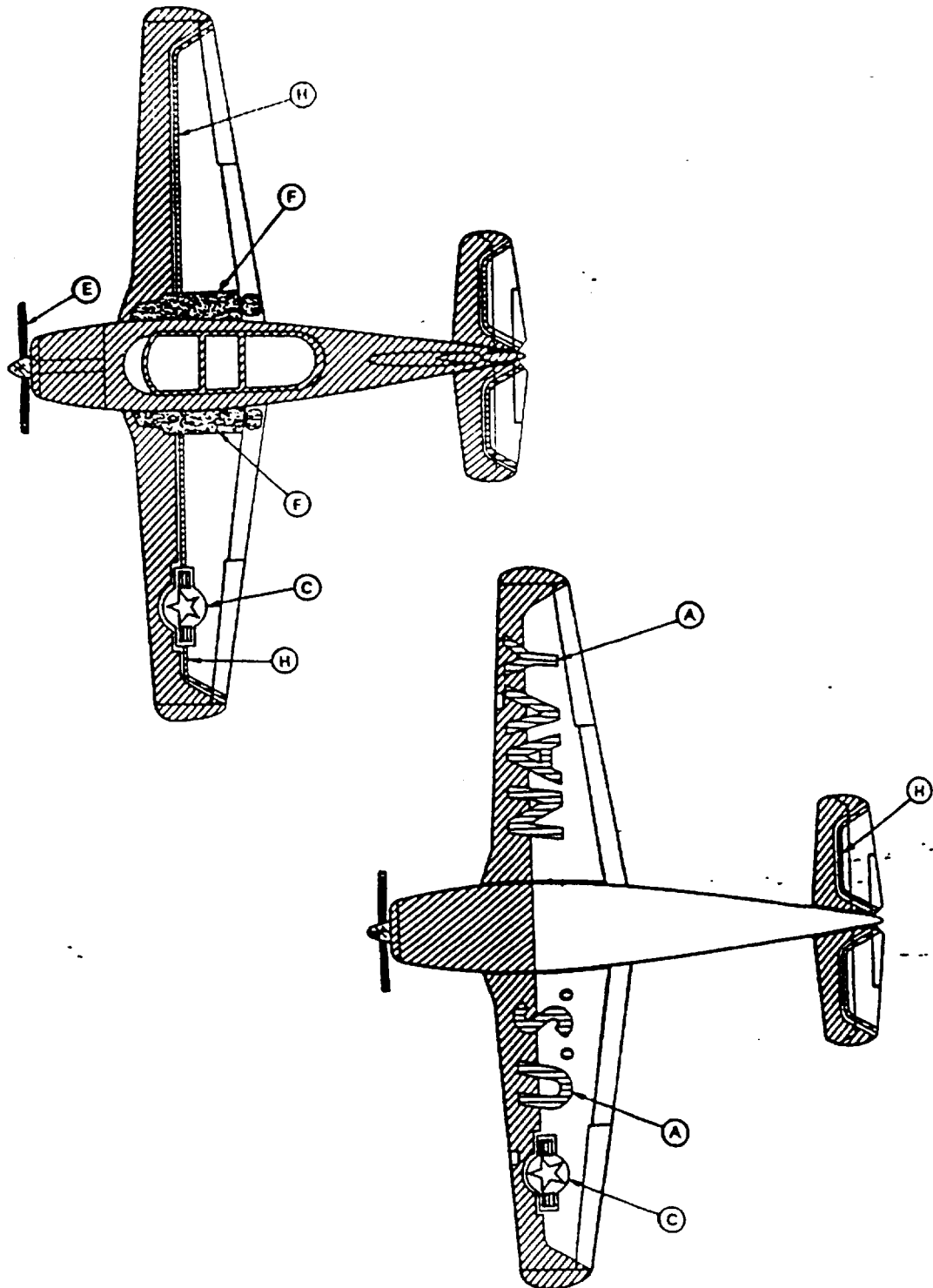


FIGURE D-10. T-34B aircraft marking (high visibility) - Continued.

MIL-STD-2161A(AS)

APPENDIX E

TACTICAL PAINT SCHEME PATTERNS

10. SCOPE

10.1 Scope. This Appendix illustrates paint schemes for tactical aircraft.

10.2 Use. This Appendix is a mandatory part of this standard. The information contained herein is intended for compliance.

20. APPLICABLE DOCUMENTS. This section is not applicable to this section.

30. DEFINITIONS

30.1 Definitions. For purposes of this Appendix, the definitions of this standard shall apply.

40. GENERAL REQUIREMENTS

40.1 Aircraft paint schemes. The following figures illustrate paint schemes for tactical aircraft.

MIL-STD-2161A(AS)

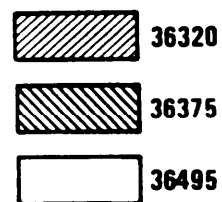
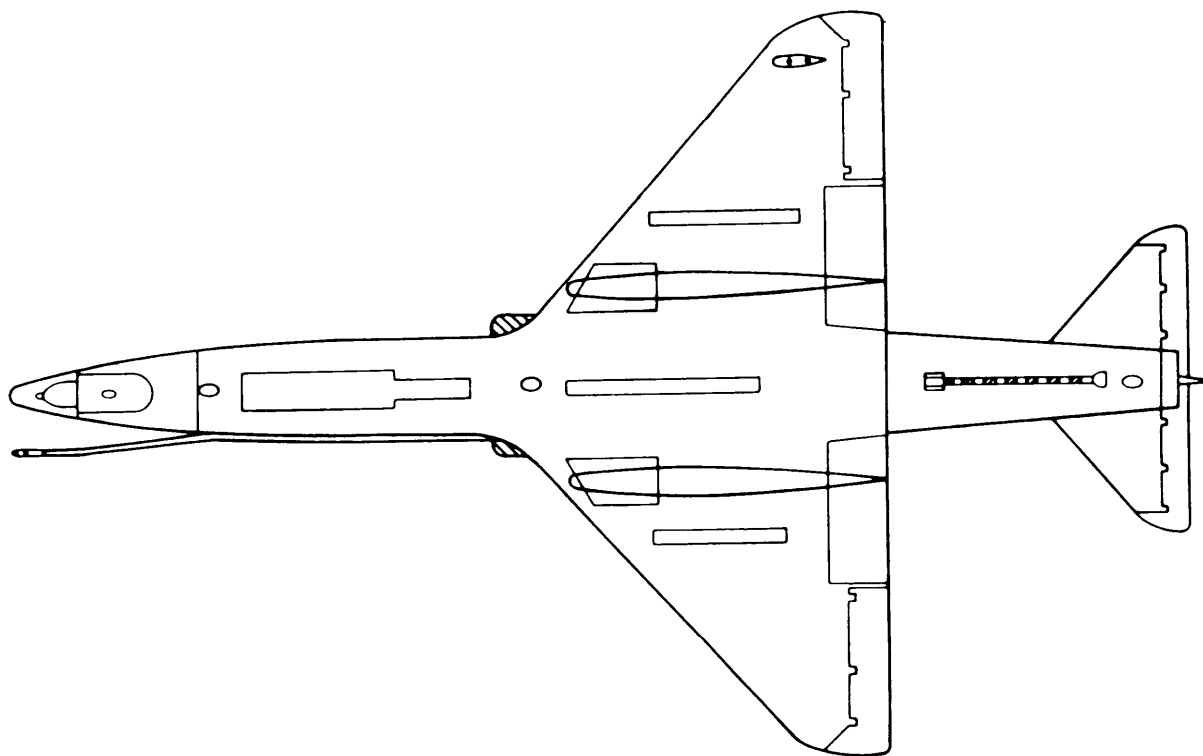


FIGURE E-1. A/TA-4 tactical paint scheme.

MIL-STD-2161A(AS)

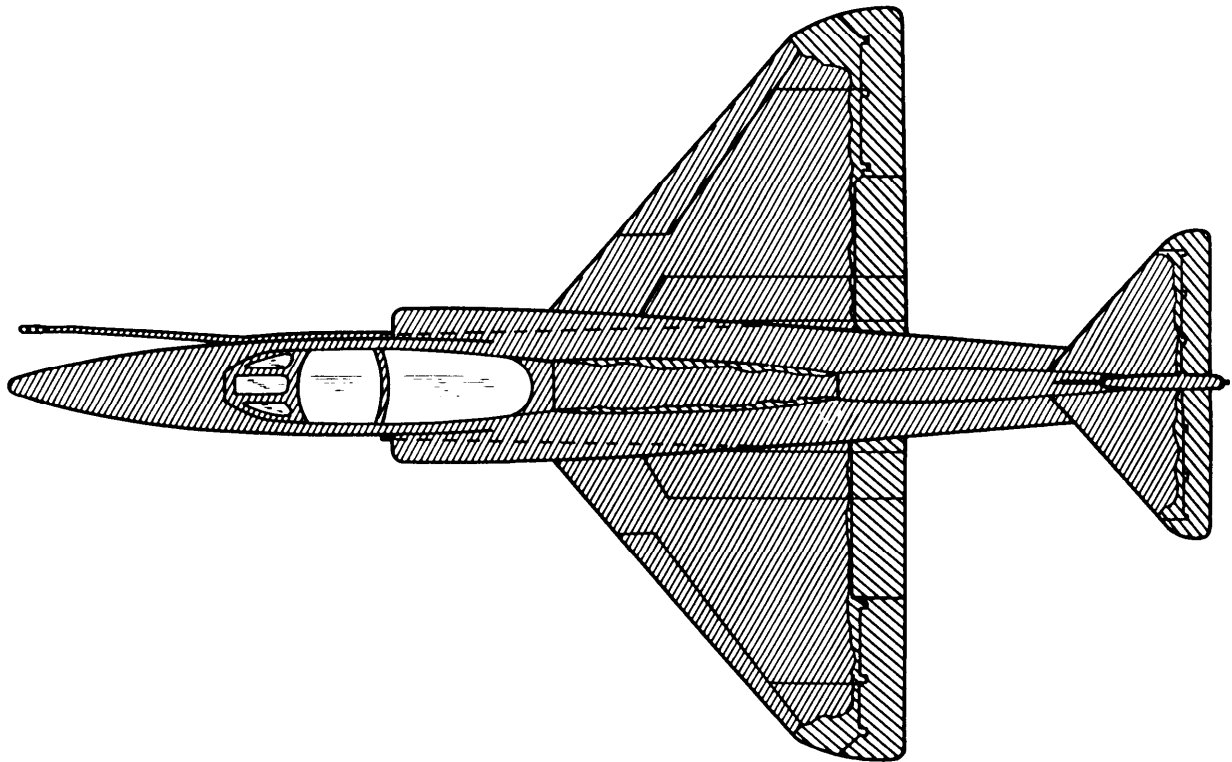
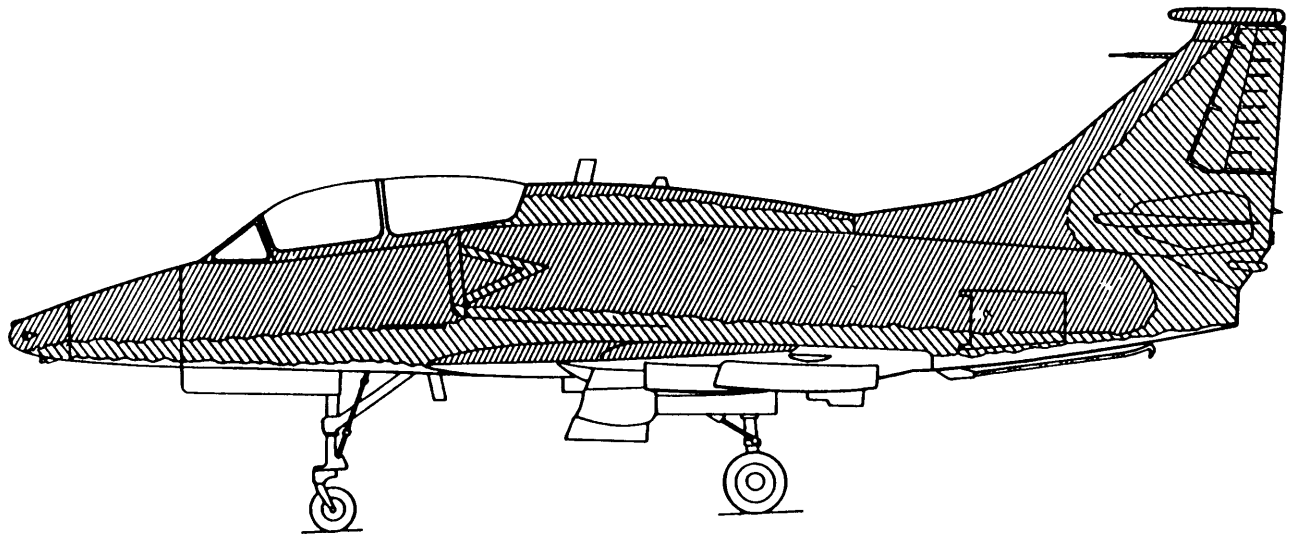


FIGURE E-1. A/TA-4 tactical paint scheme - Continued.

MIL-STD-2161A(AS)

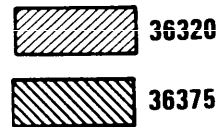
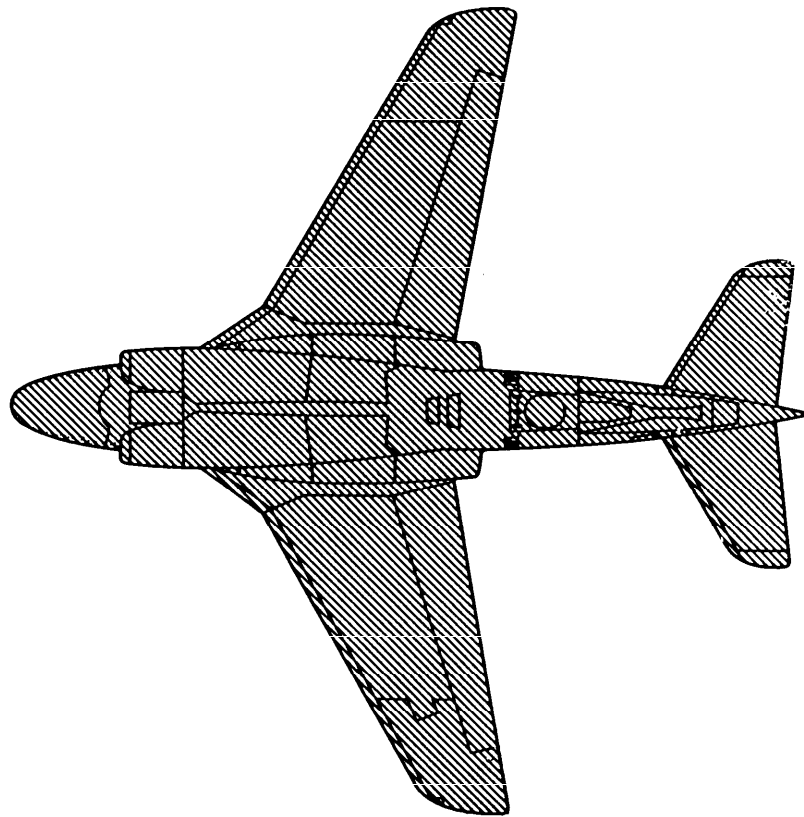


FIGURE E-2. A-6 tactical paint scheme.

MIL-STD-2161A(AS)

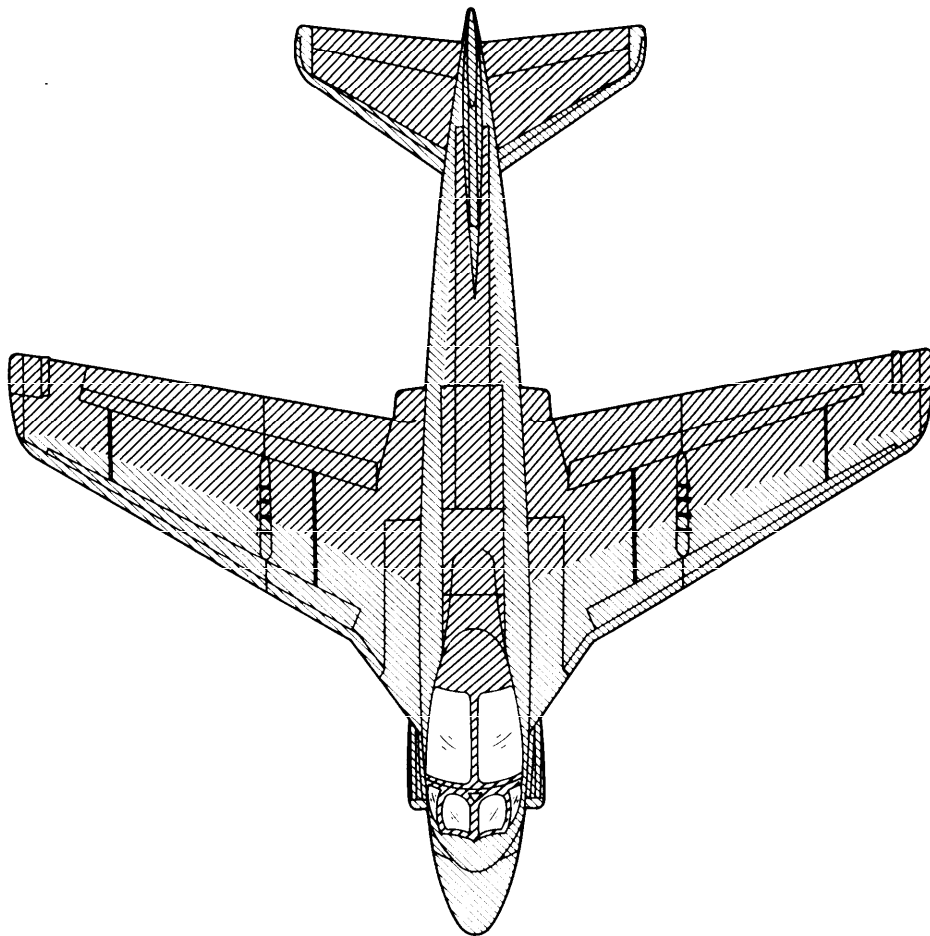
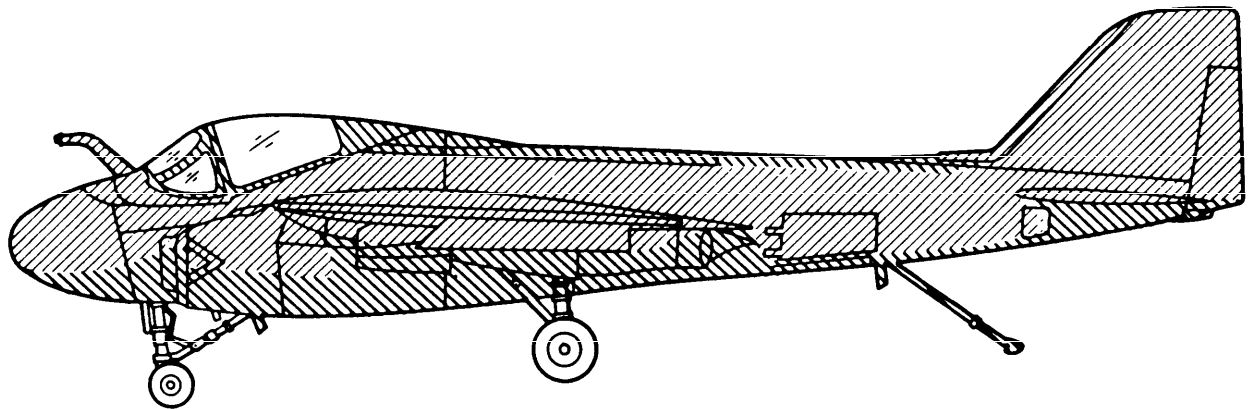


FIGURE E-2. A-6 tactical paint scheme - Continued.

MIL-STD-2161A(AS)

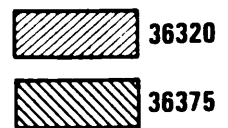
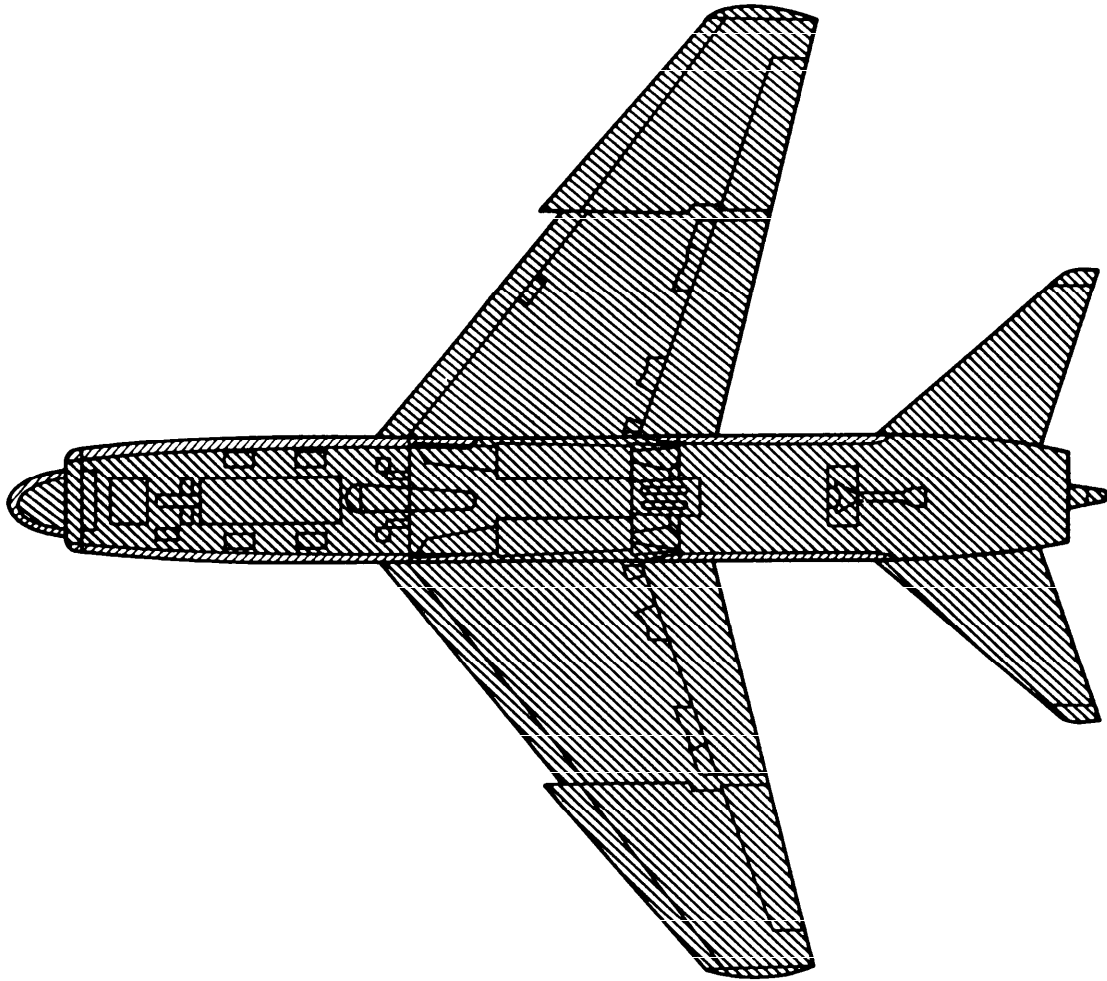


FIGURE E-3. A-7 tactical paint scheme.

MIL-STD-2161A(AS)

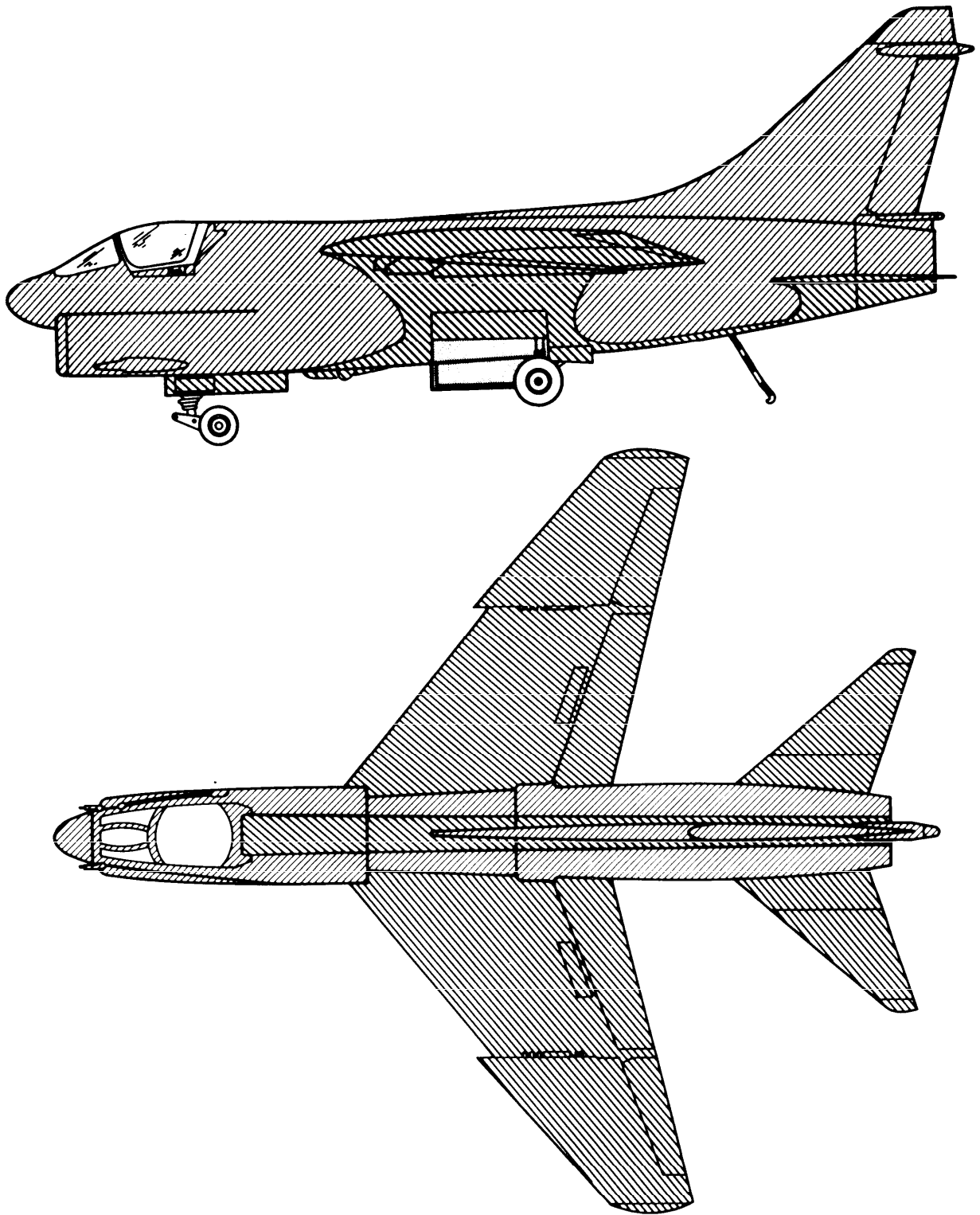


FIGURE E-3. A-7 tactical paint scheme - Continued.

MIL-STD-2161A(AS)

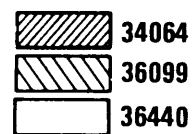
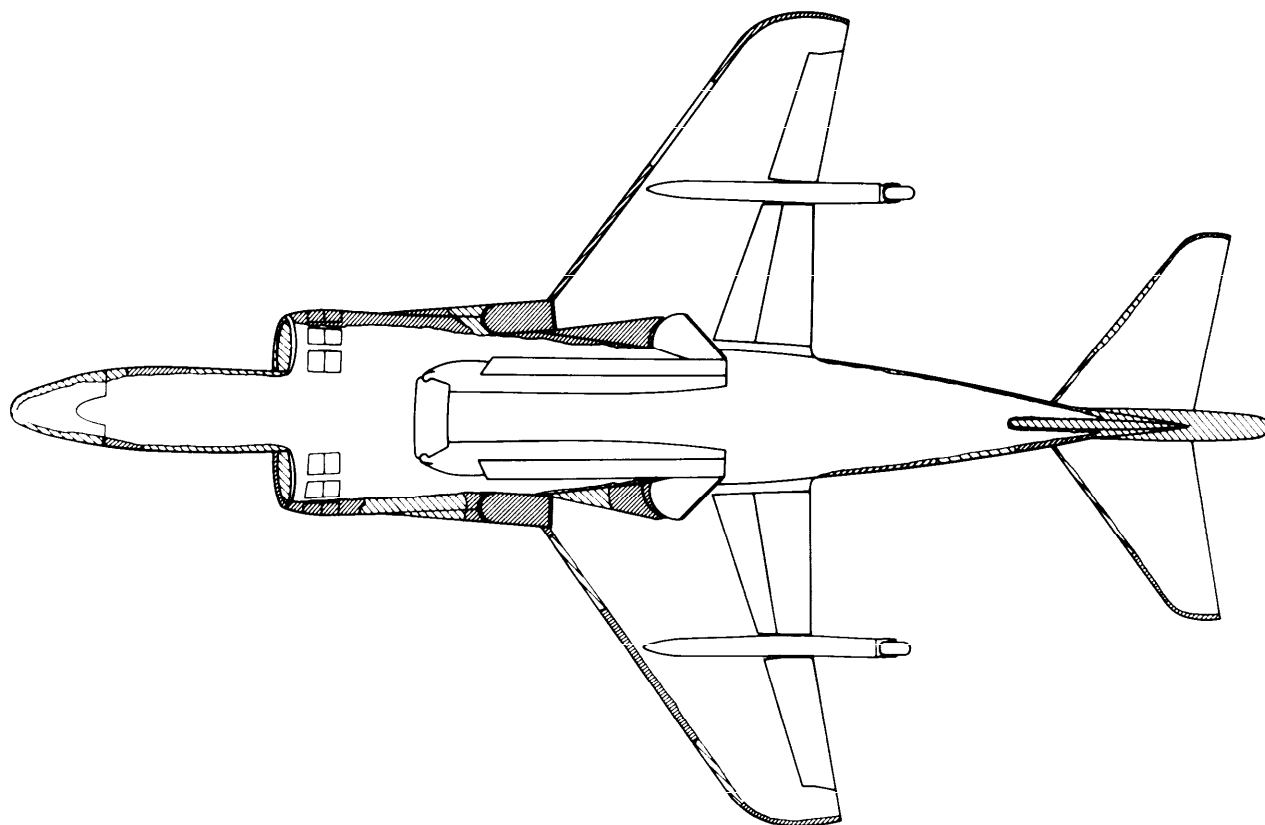


FIGURE E-4. AV-8B land camouflage paint scheme.

MIL-STD-2161A(AS)

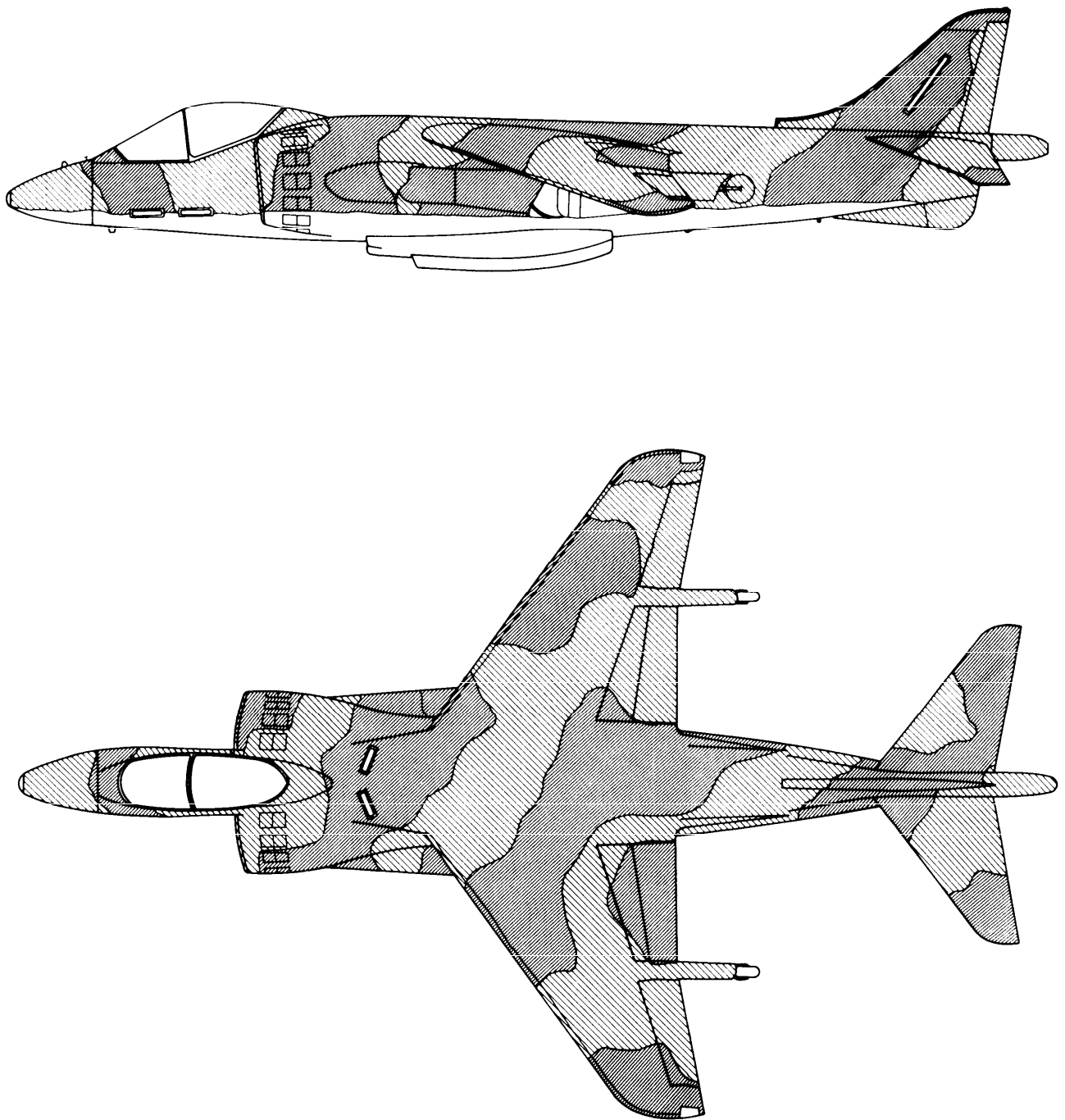


FIGURE E-4. AV-8B land camouflage paint scheme - Continued.

MIL-STD-2161A(AS)

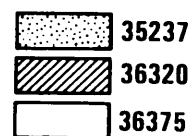
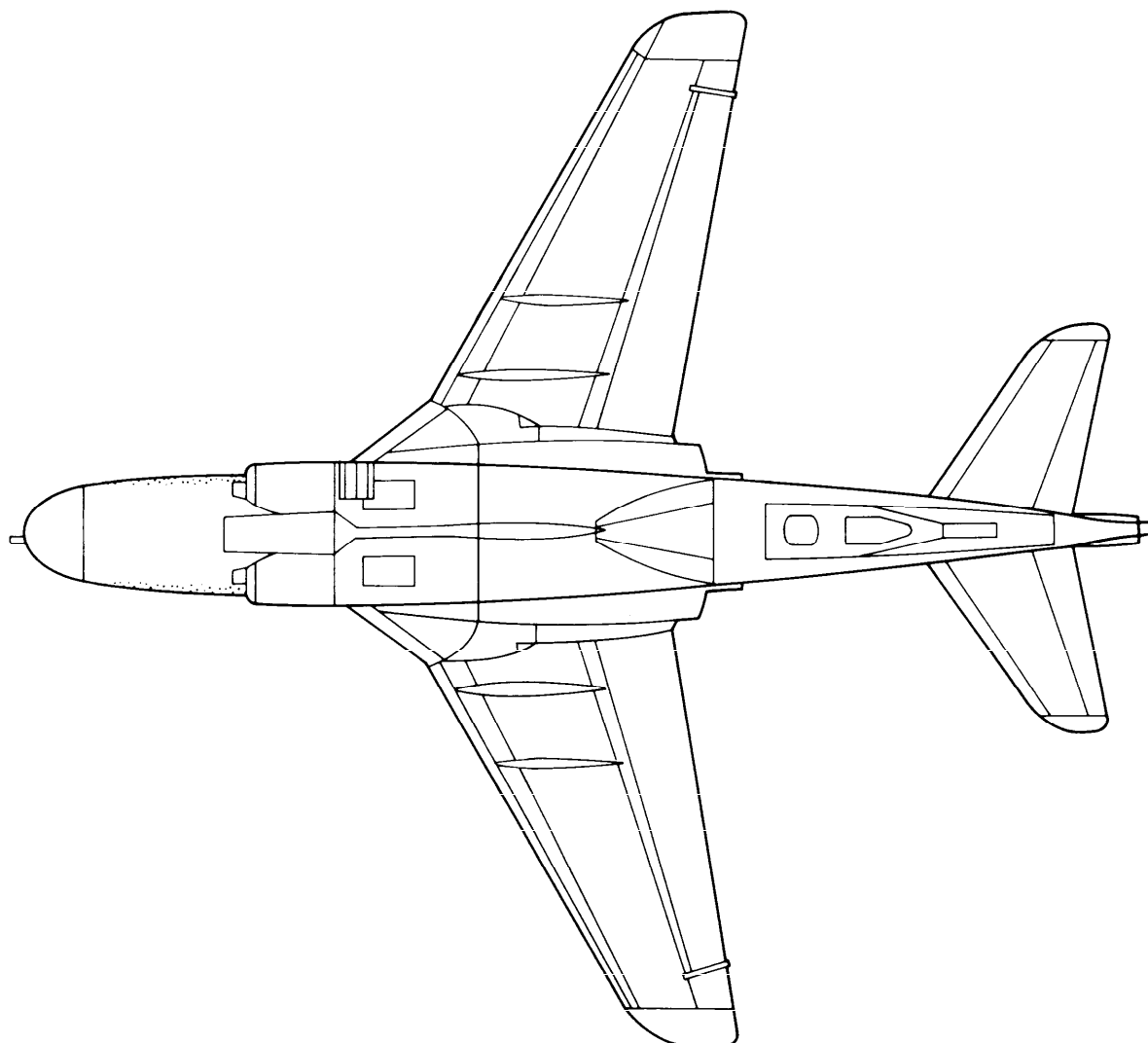


FIGURE E-5. EA-6B tactical paint scheme.

MIL-STD-2161A(AS)

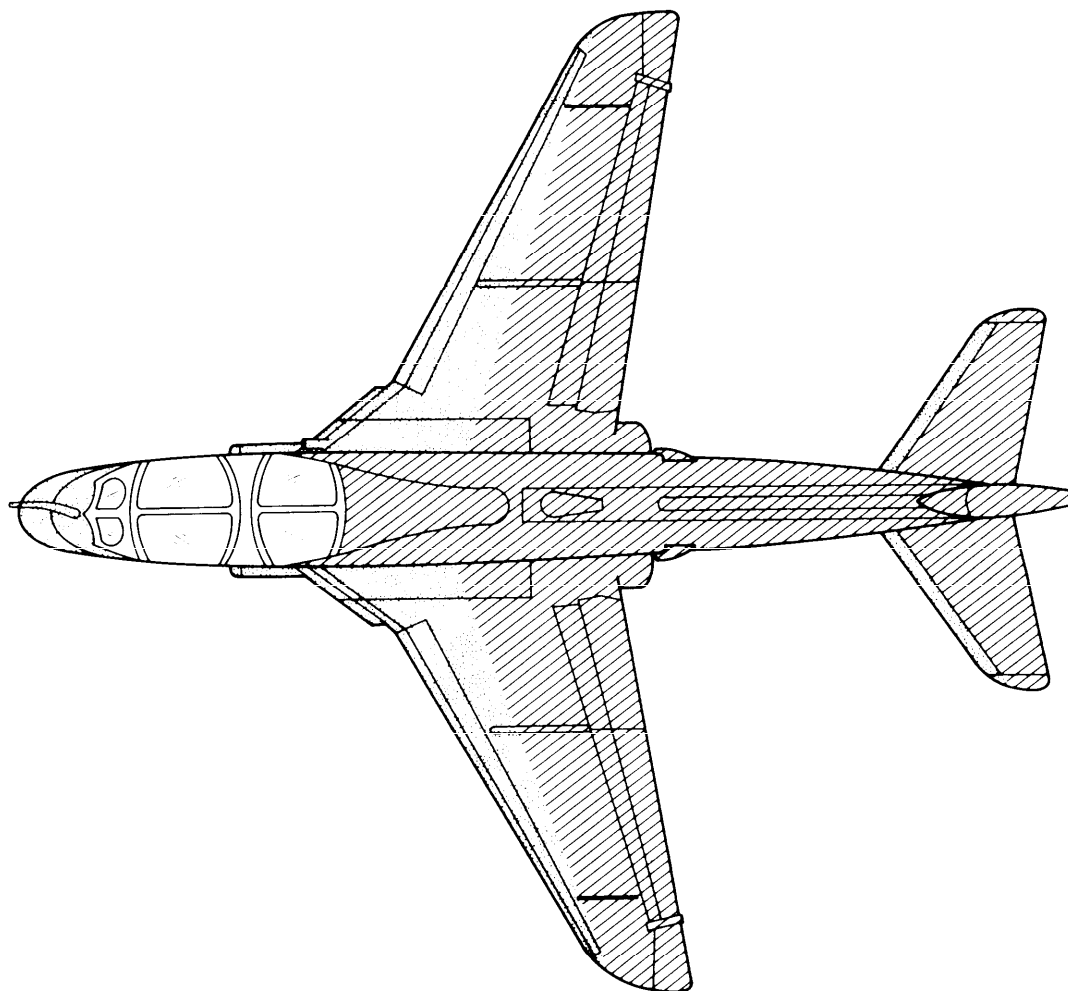
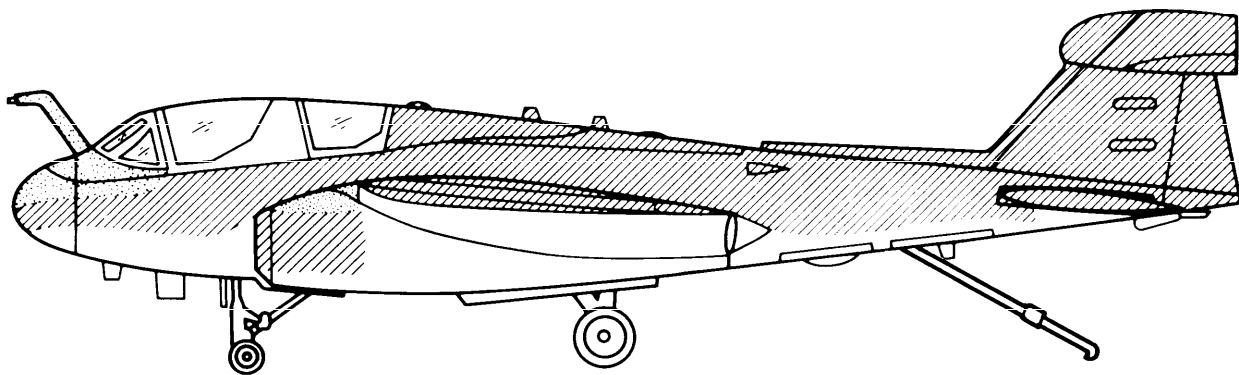
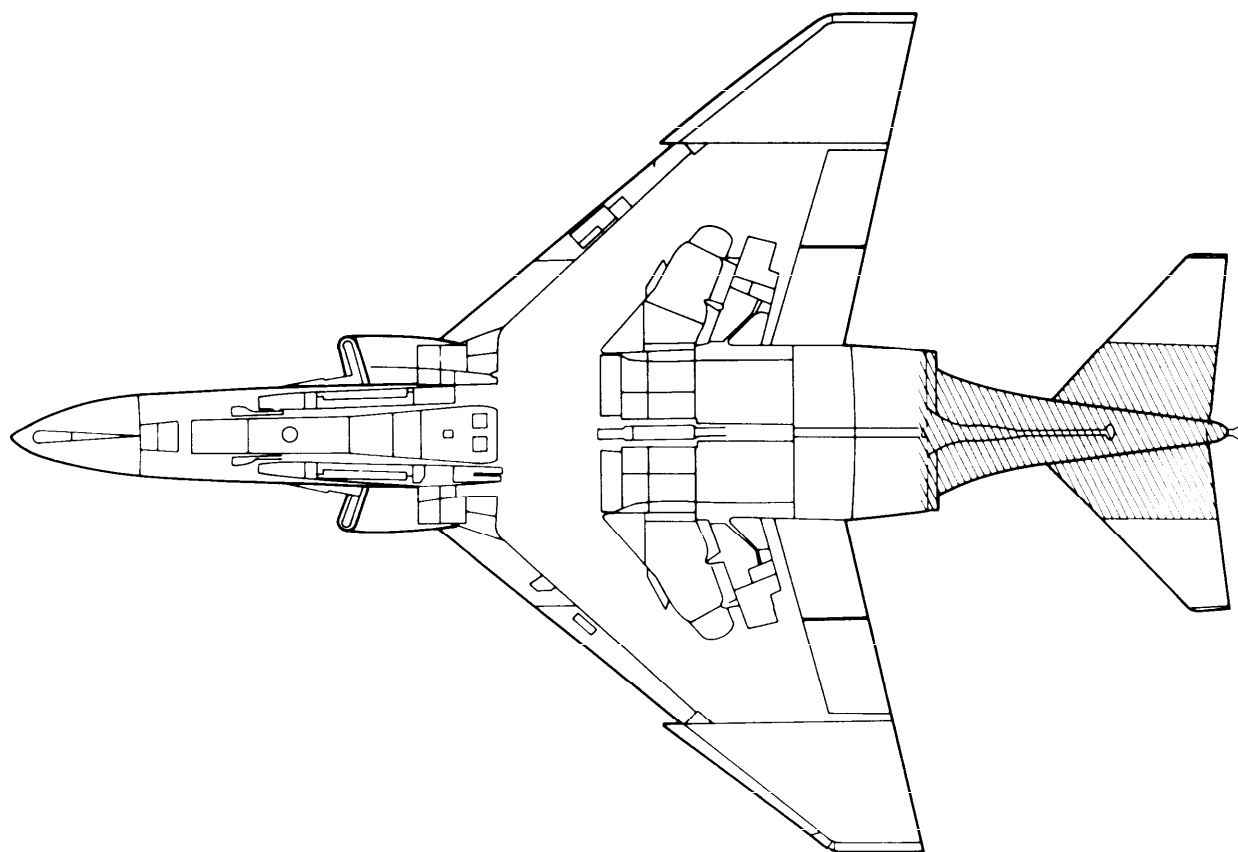


FIGURE E-5. EA-6B tactical paint scheme - Continued.

MIL-STD-2161A(AS)







	35237
	36320
	UNPAINTED
	36375

FIGURE E-6. RF/F-4 tactical paint scheme.

MIL-STD-2161A(AS)

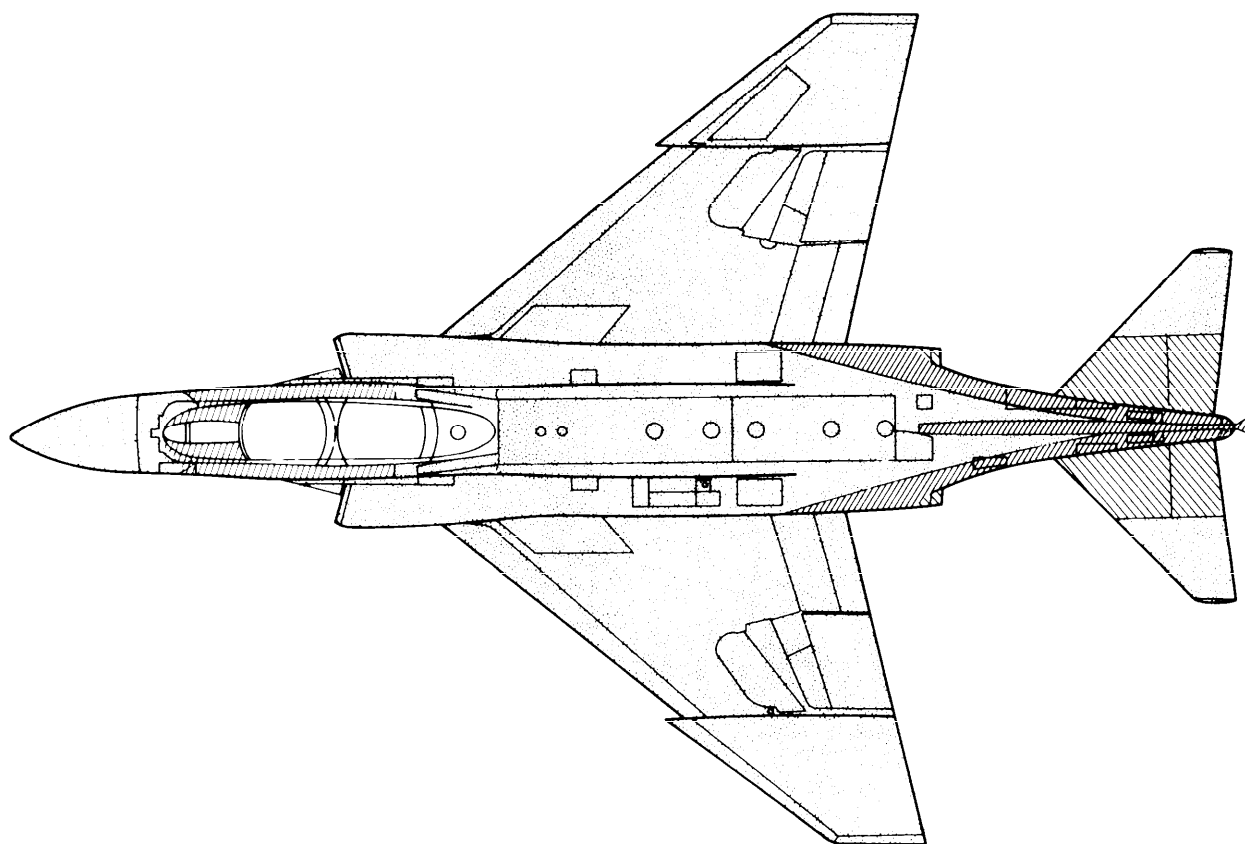
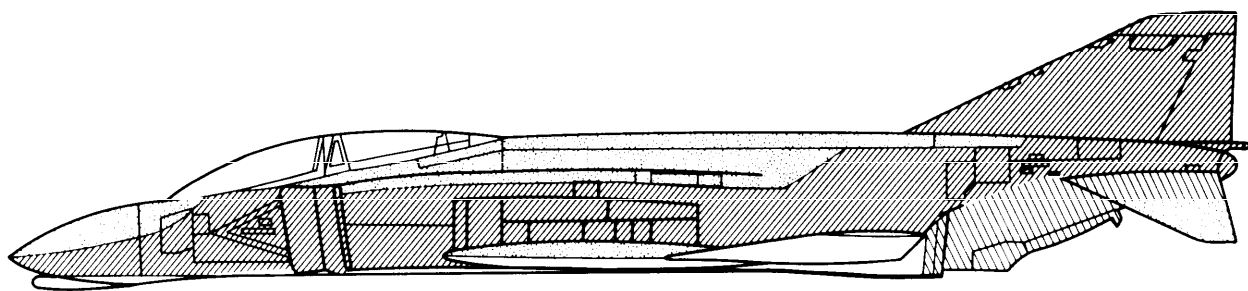


FIGURE E-6. RF/F-4 tactical paint scheme - Continued.

MIL-STD-2161A(AS)

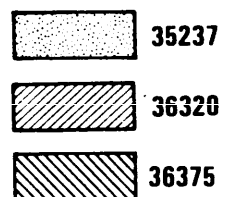
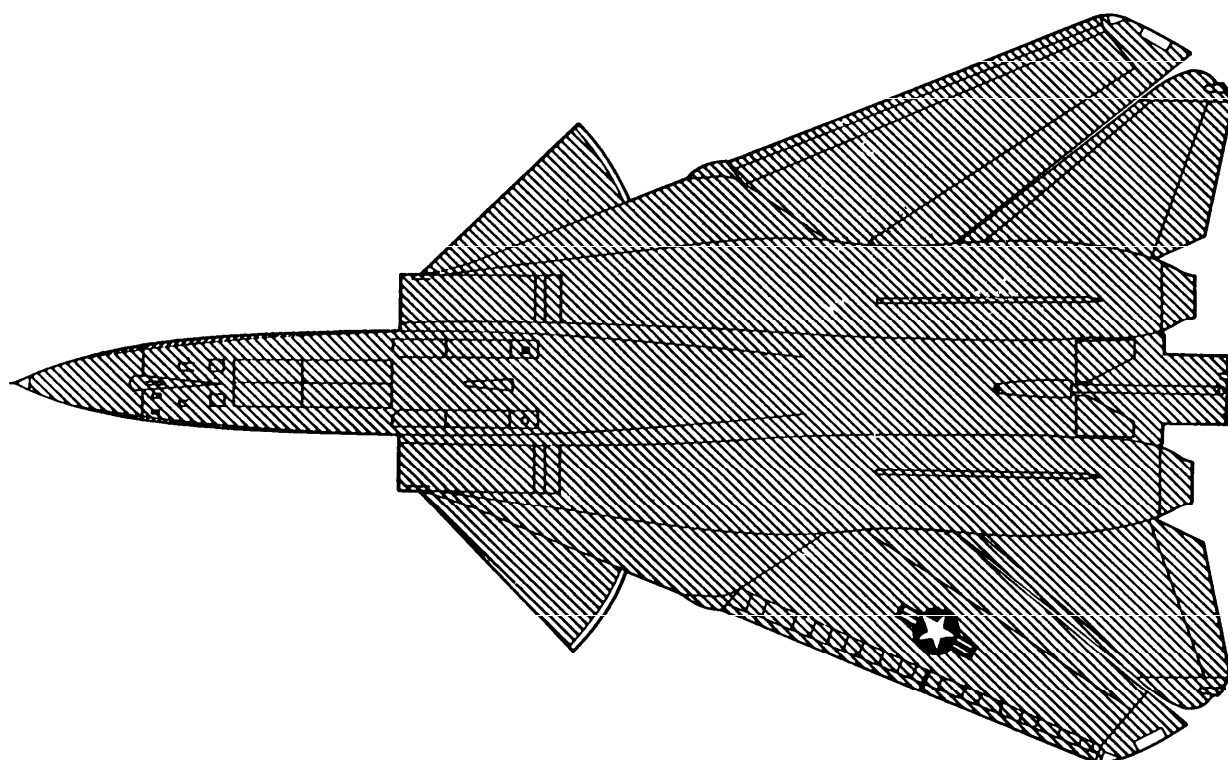


FIGURE E-7. F-14 tactical paint scheme.

MIL-STD-2161A(AS)

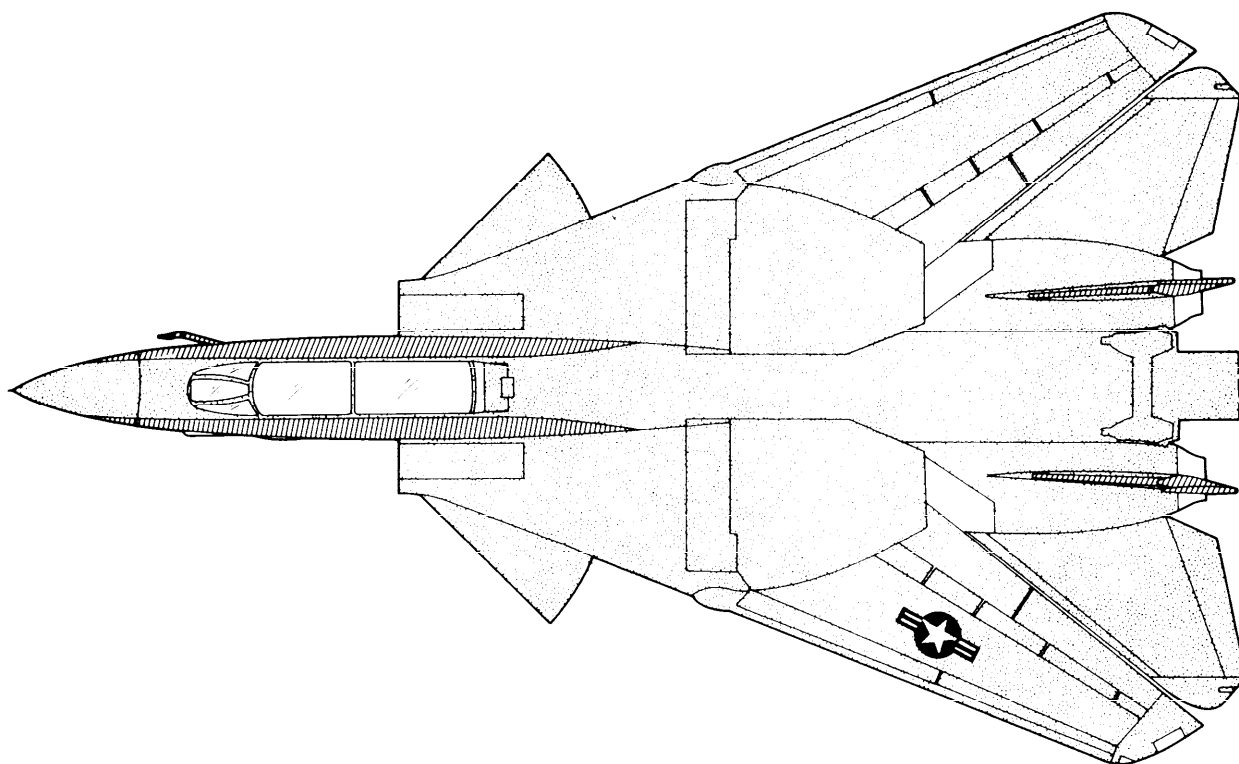
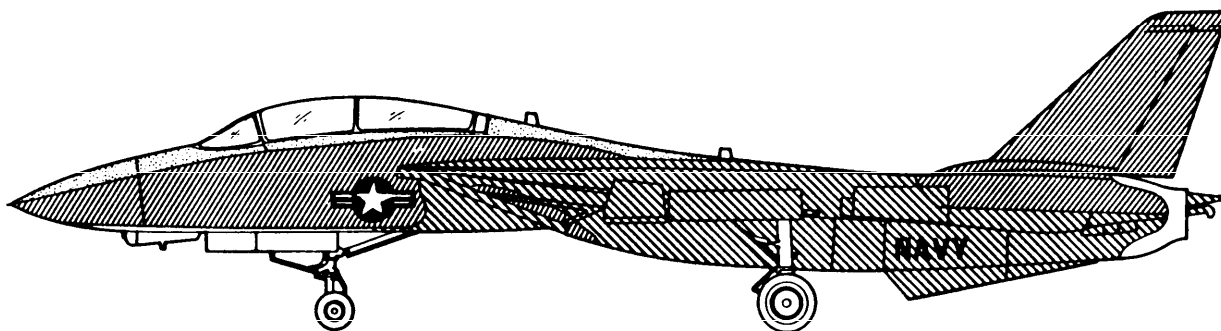


FIGURE E-7. F-14 tactical paint scheme - Continued.

MIL-STD-2161A(AS)

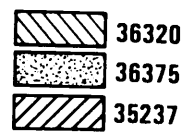
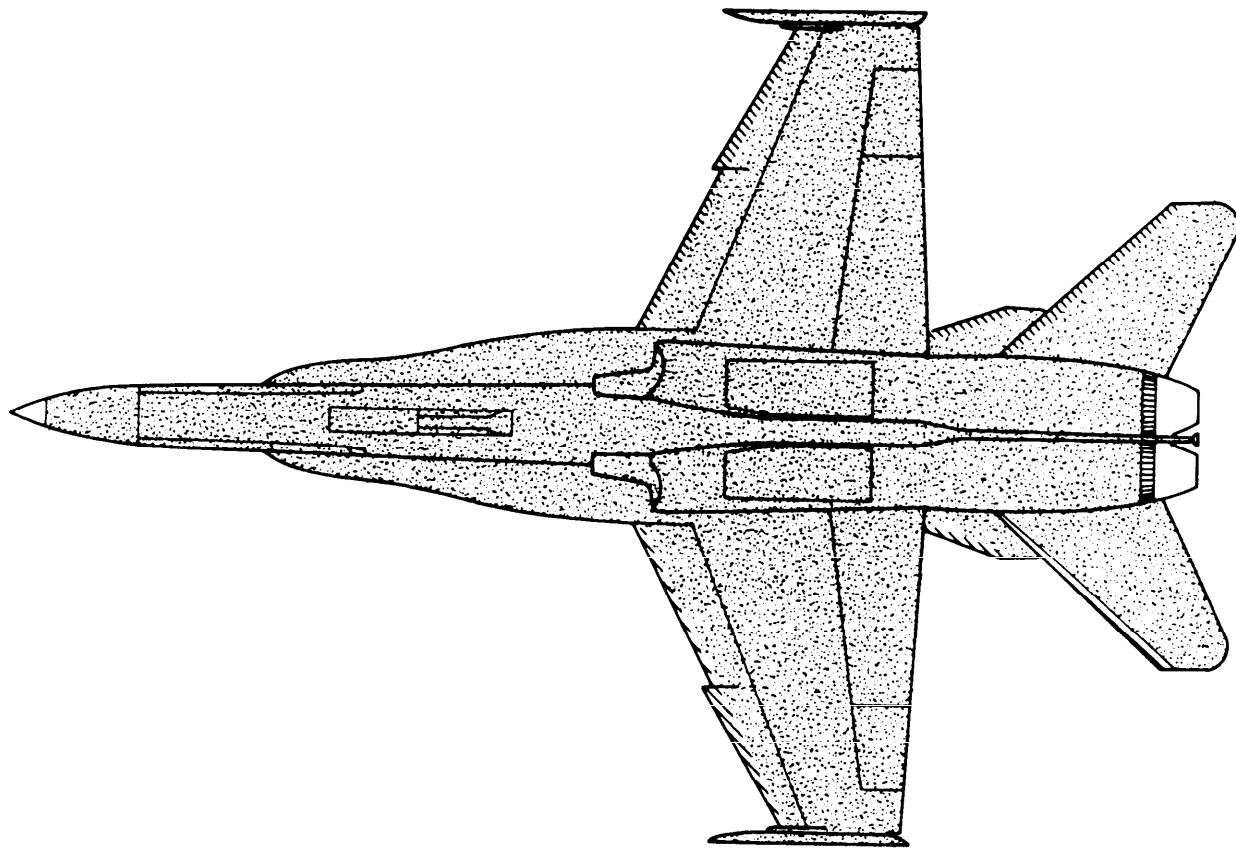


FIGURE E-8. F-18 tactical paint scheme.

MIL-STD-2161A(AS)

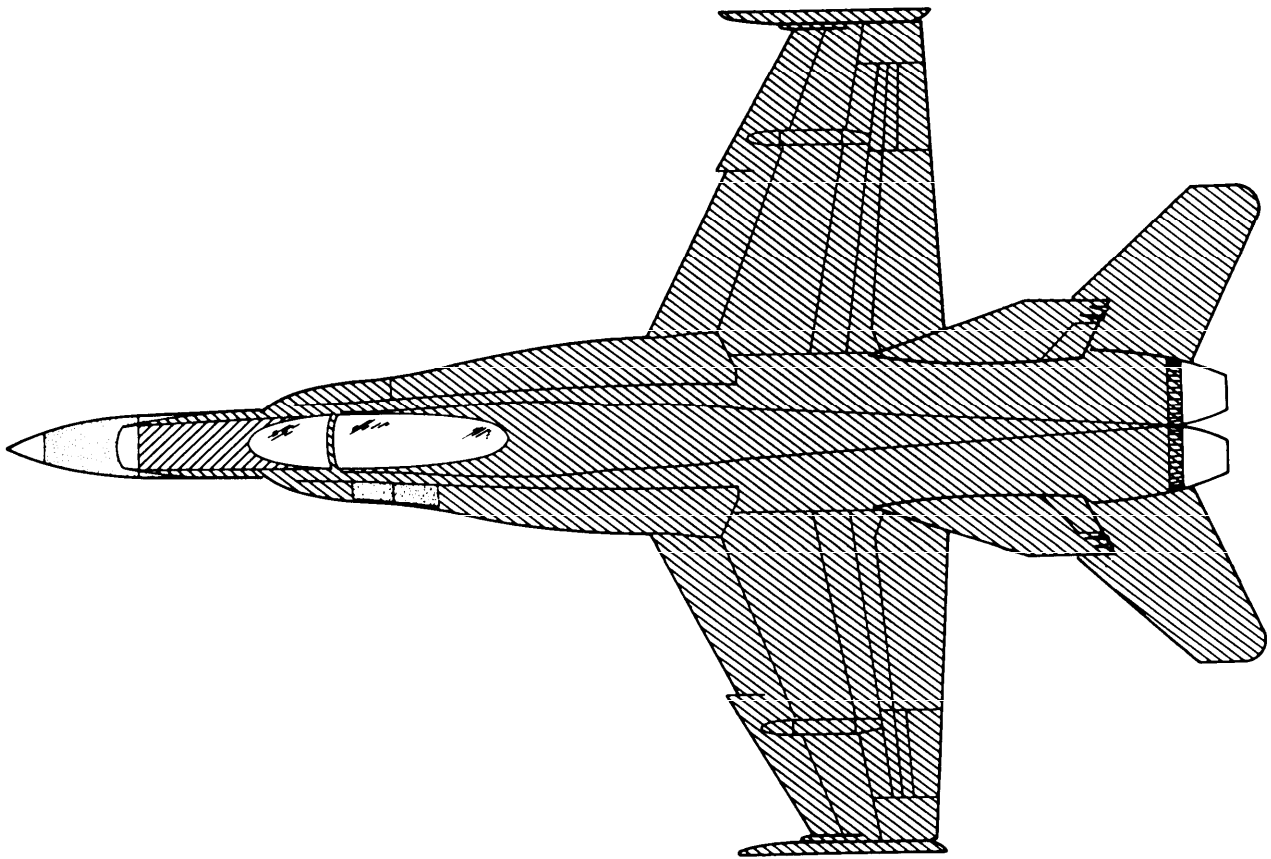
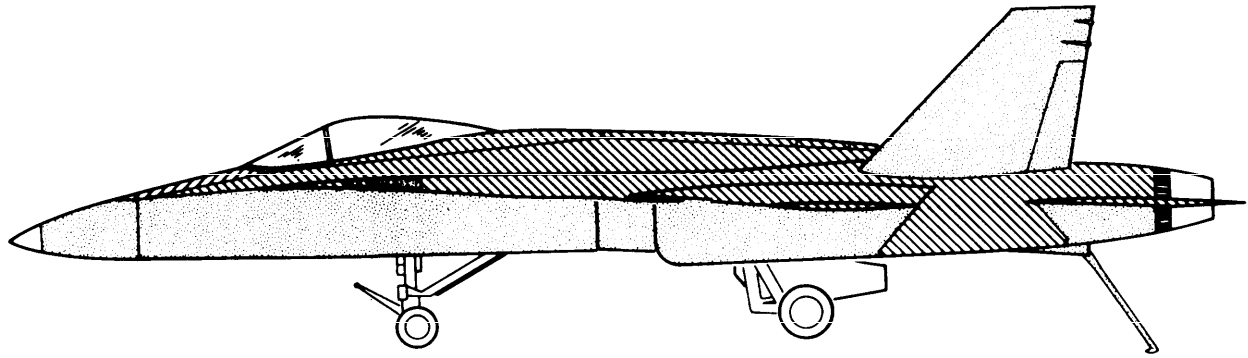


FIGURE E-8. F-18 tactical paint scheme - Continued.

MIL-STD-2161A(AS)

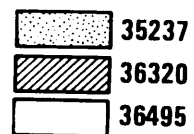
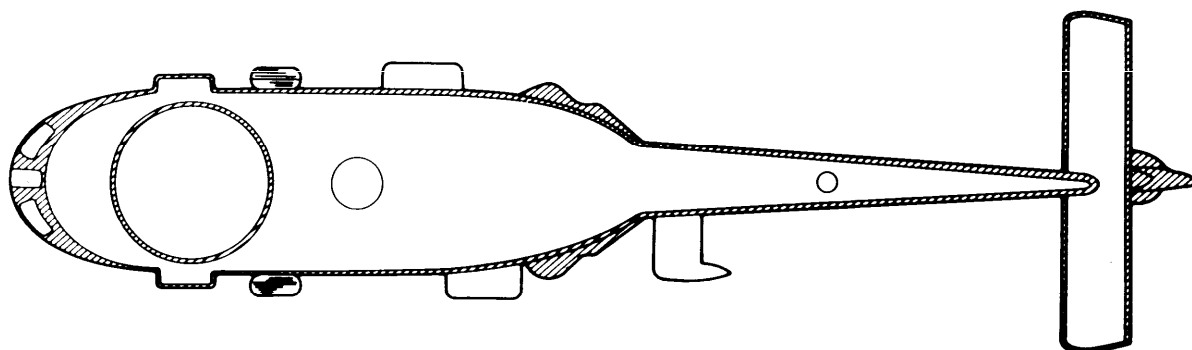


FIGURE E-9. SH-60B tactical paint scheme.

MIL-STD-2161A(AS)

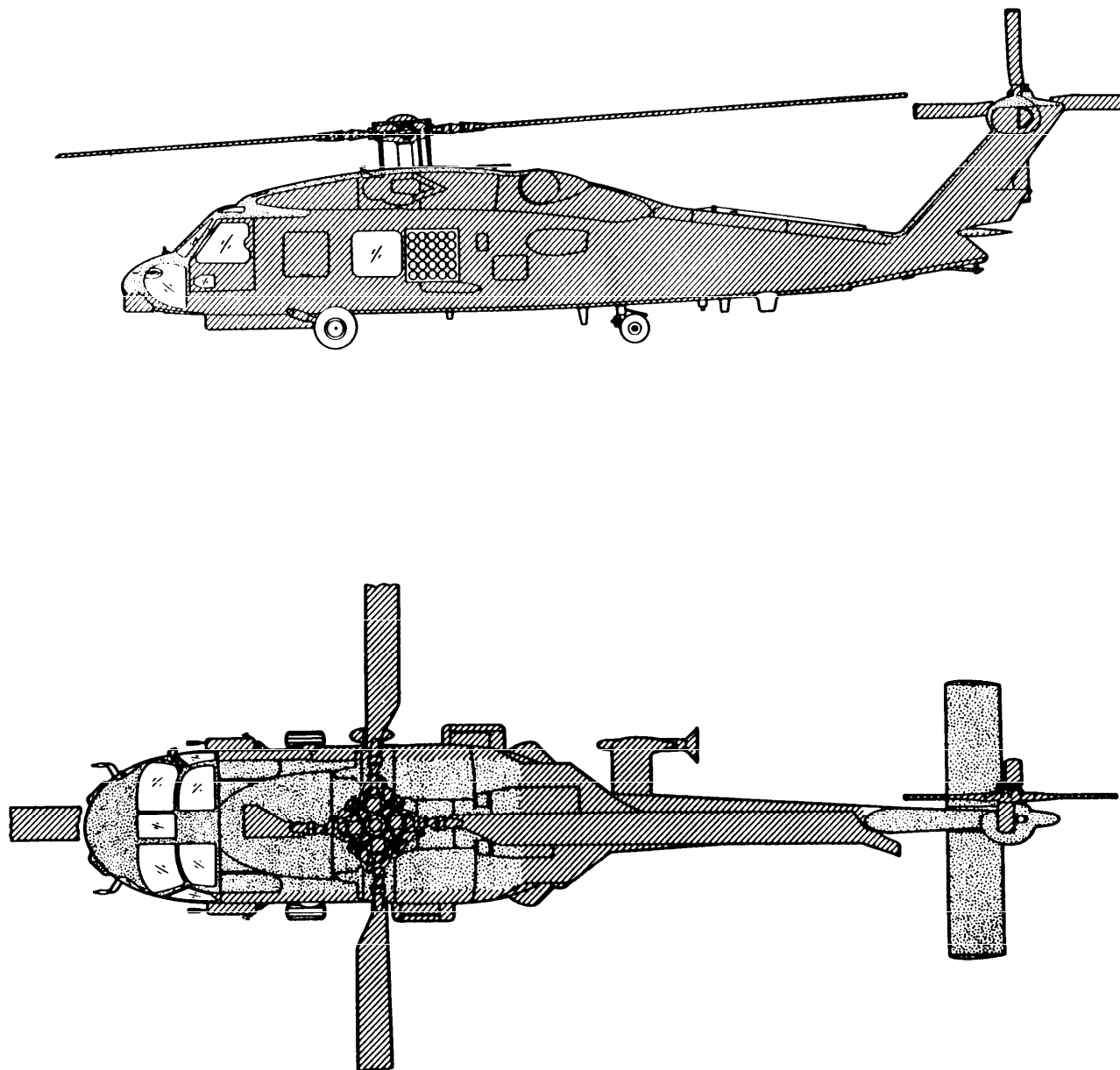


FIGURE E-9. SH-60B tactical paint scheme - Continued.

MIL-STD-2161A(AS)

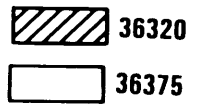
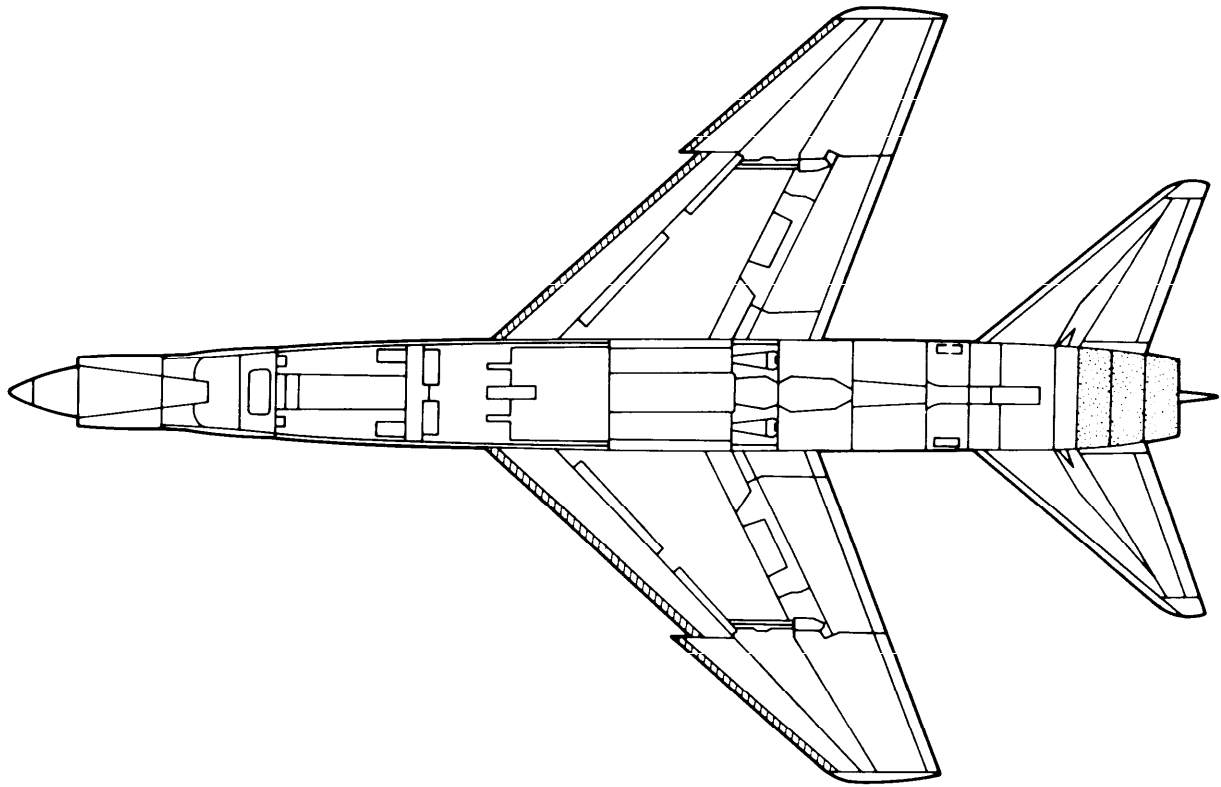


FIGURE E-10. RF-8G tactical paint scheme.

MIL-STD-2161A(AS)

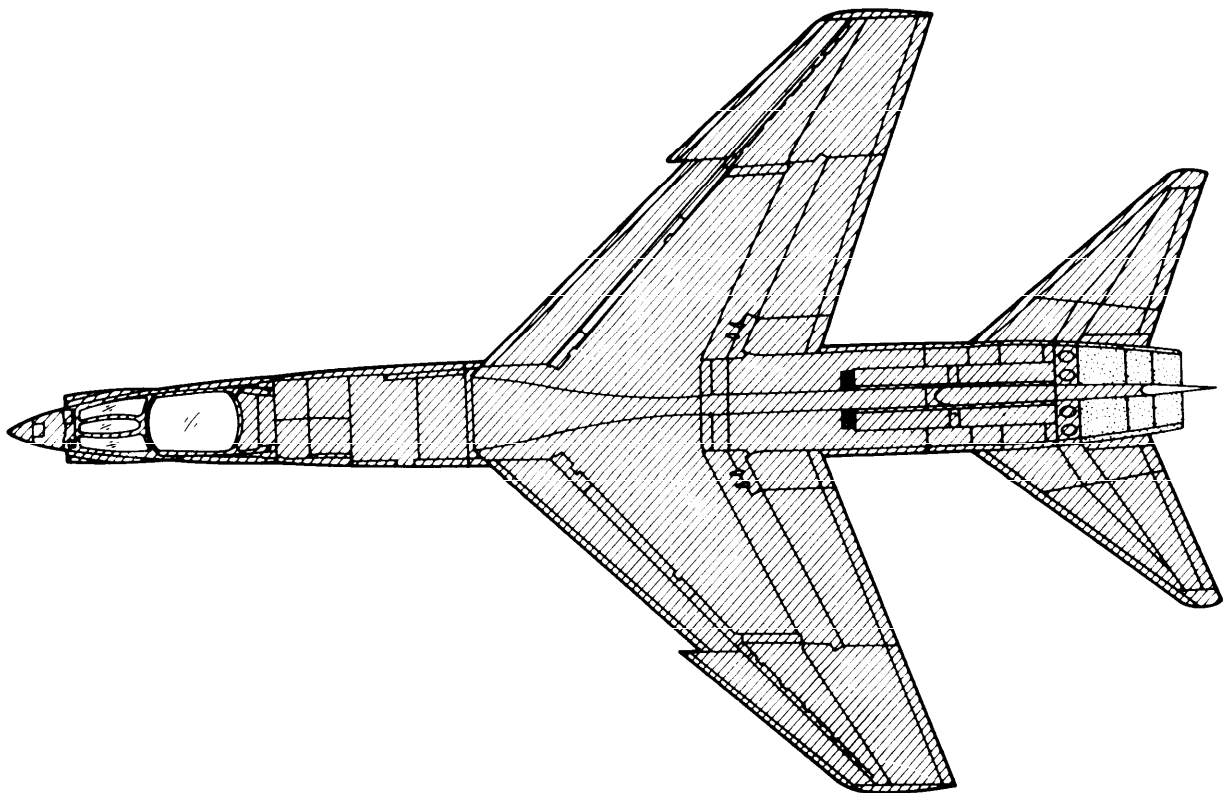
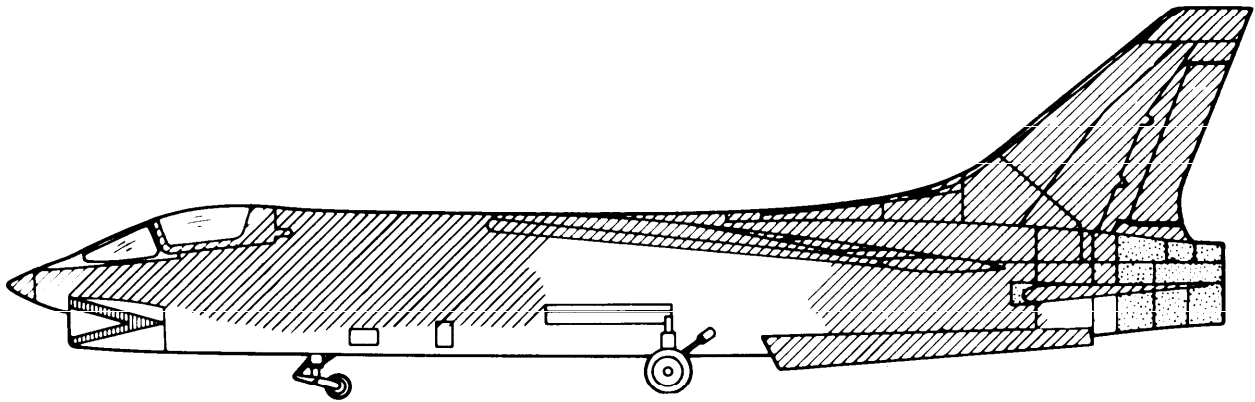
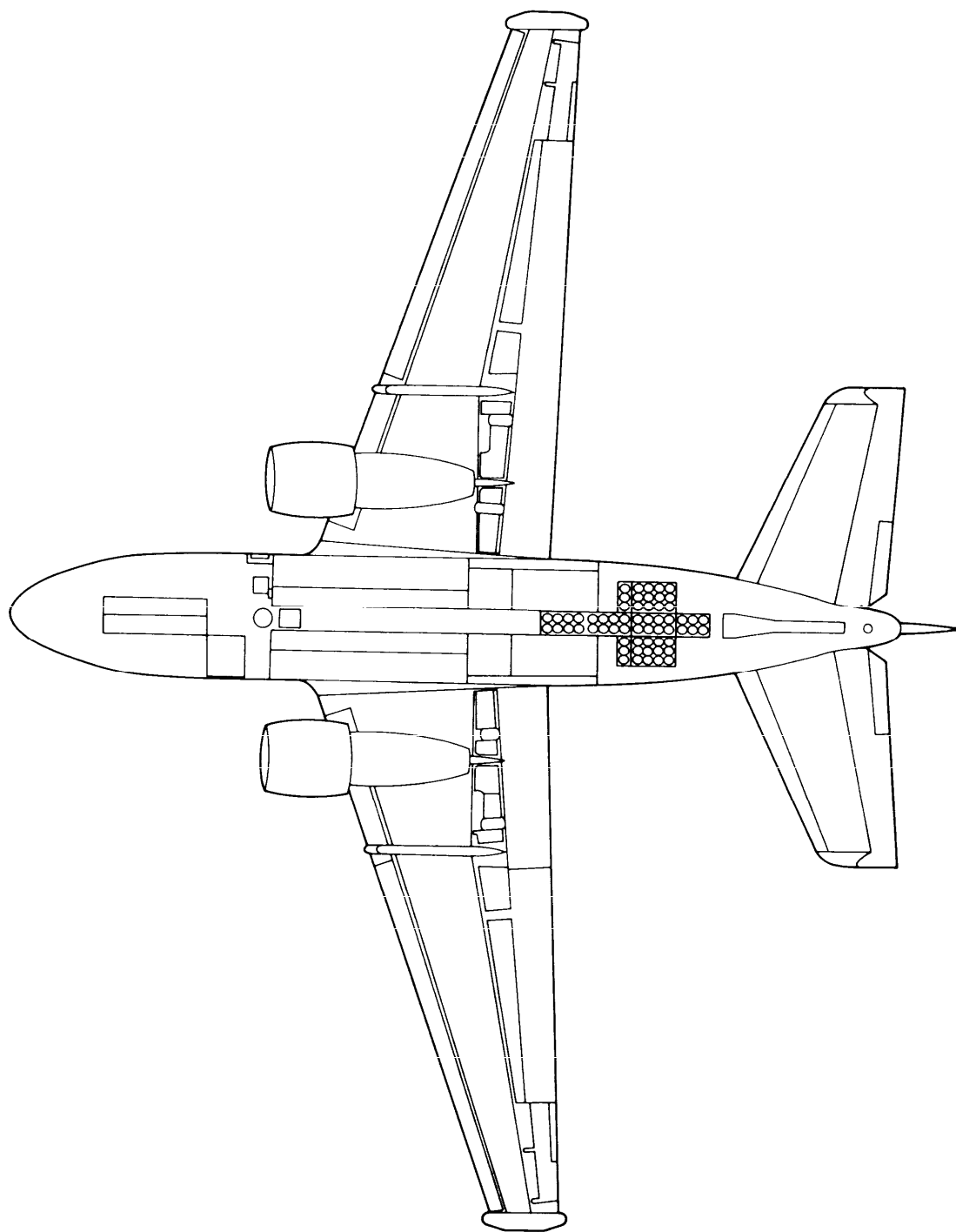


FIGURE E-10. RF-8G tactical paint scheme - Continued.

MIL-STD-2161A(AS)



36375

FIGURE E-11. S-3A/B tactical paint scheme.

MIL-STD-2161A(AS)

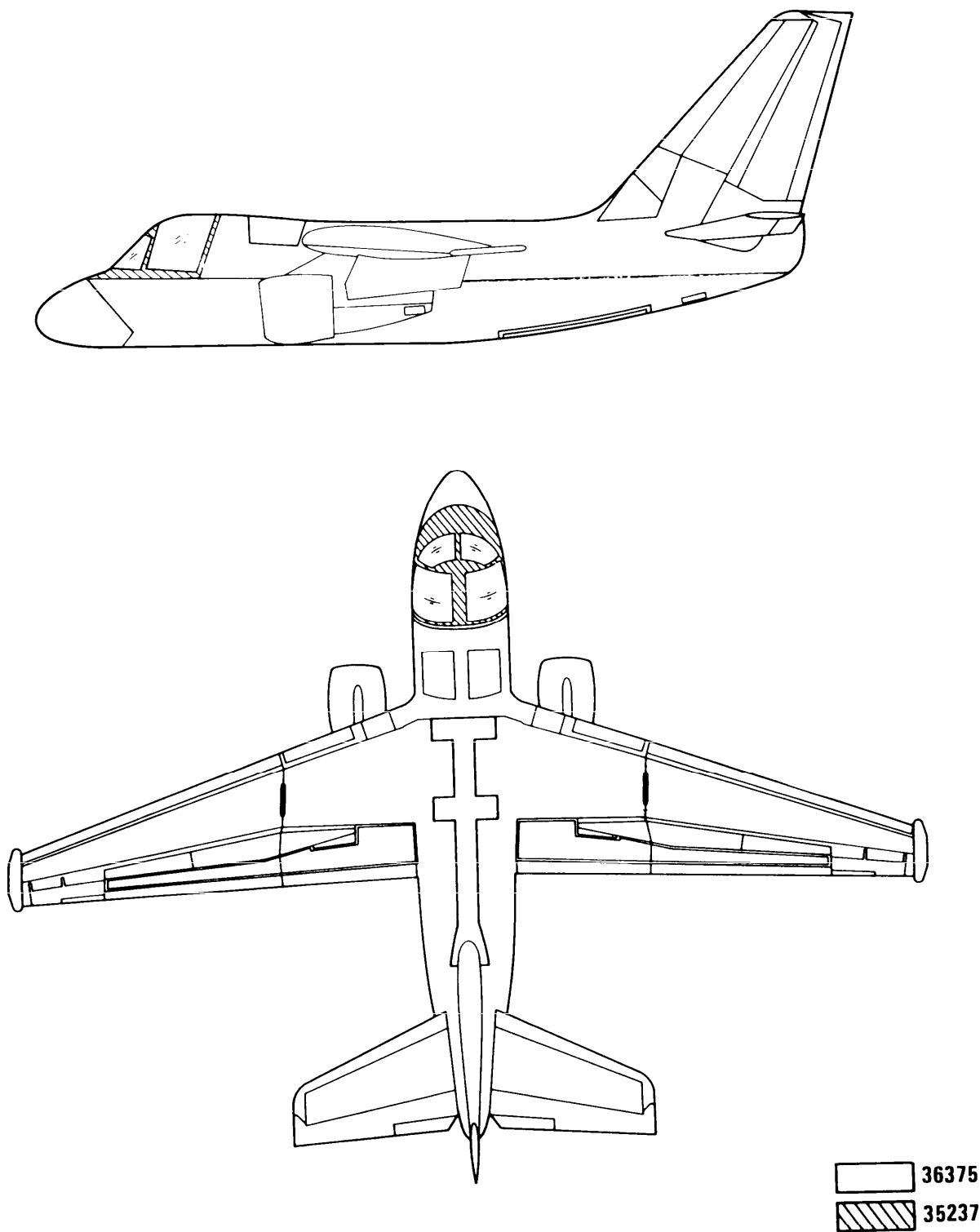


FIGURE E-11. S-3A/B tactical paint scheme - Continued.

MIL-STD-2161A(AS)

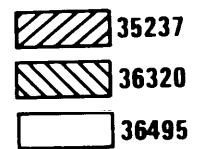
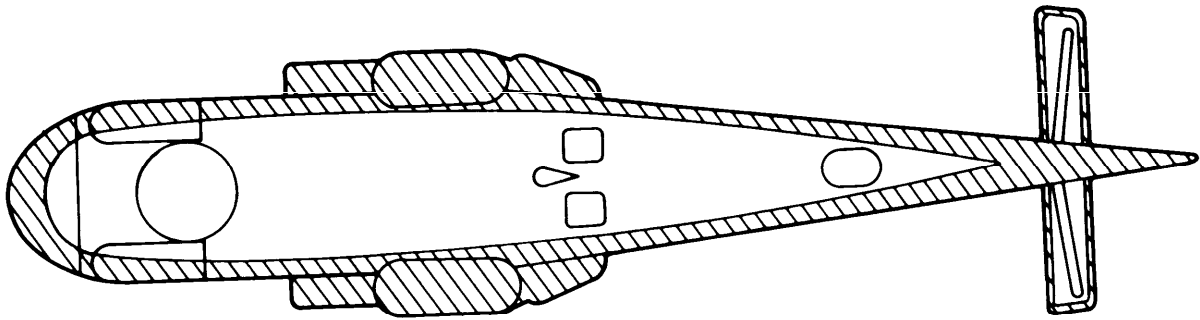


FIGURE E-12. SH-2F tactical paint scheme.

MIL-STD-2161A(AS)

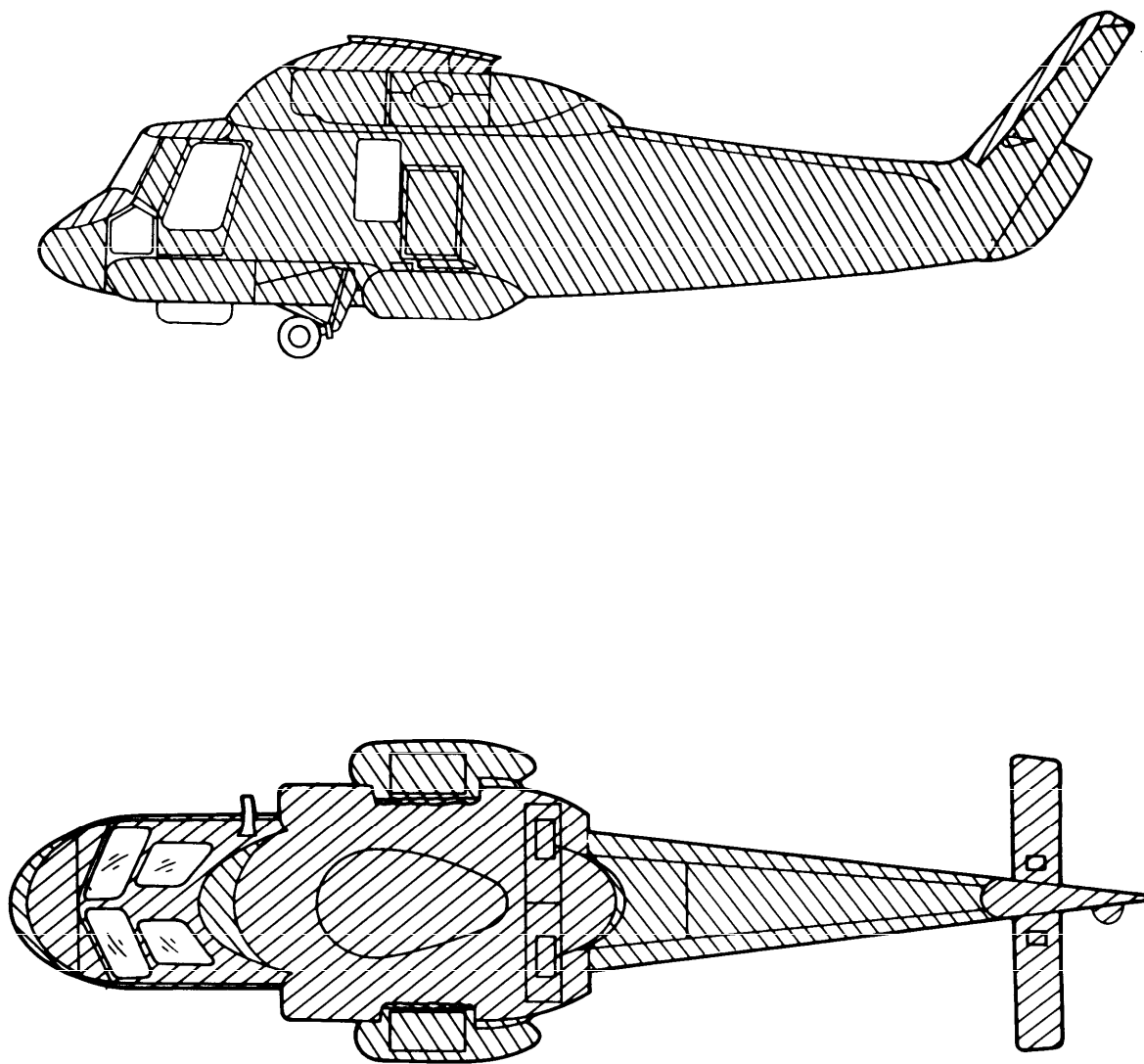


FIGURE E-12. SH-2F tactical paint scheme - Continued.

MIL-STD-2161A(AS)

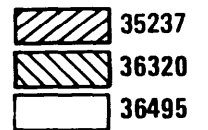
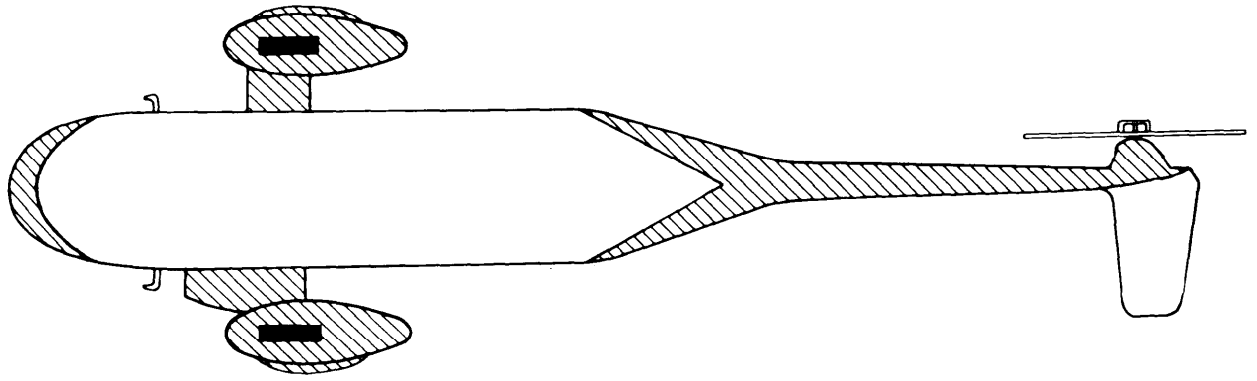


FIGURE E-13. SH-3D/H tactical paint scheme.

MIL-STD-2161A(AS)

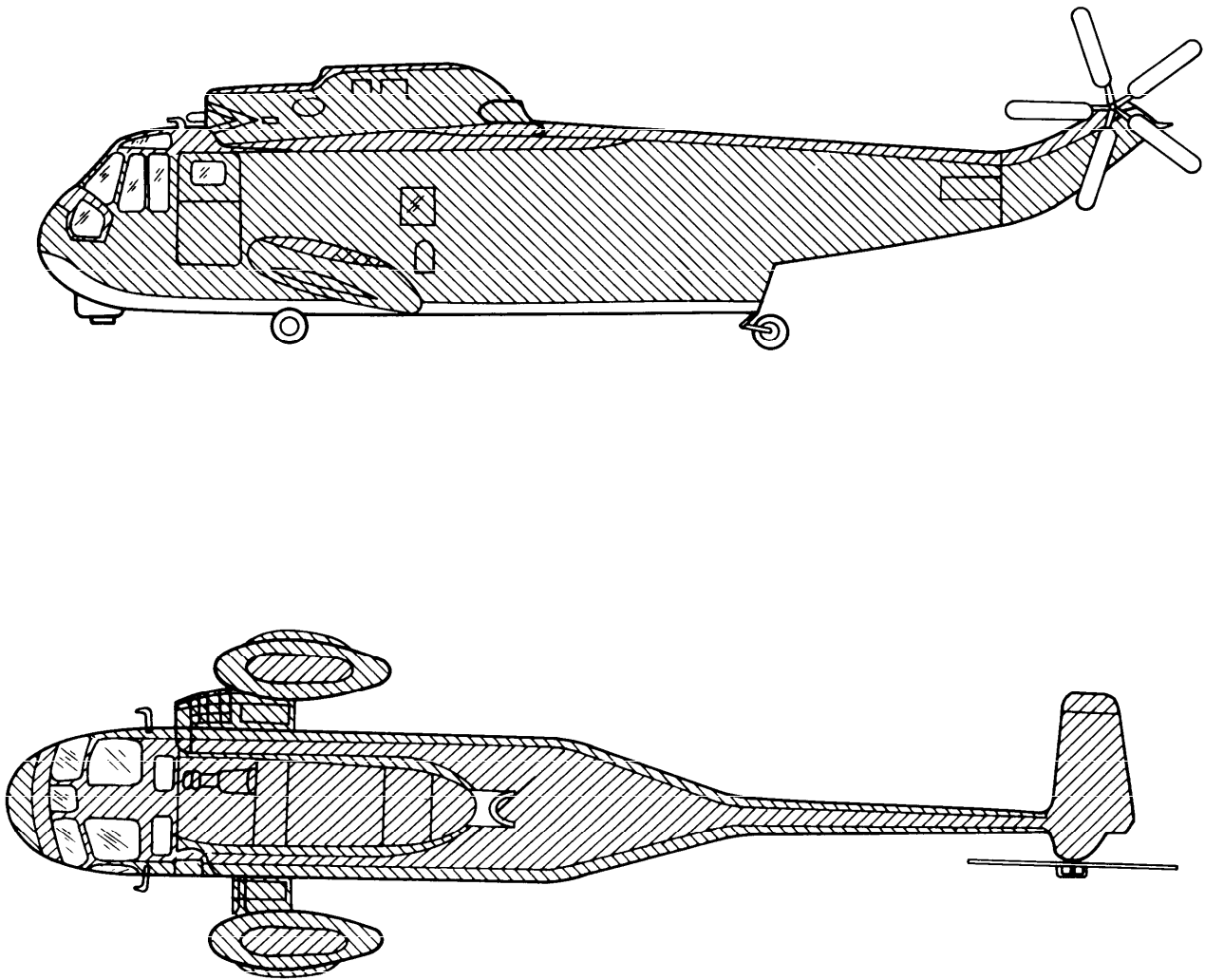
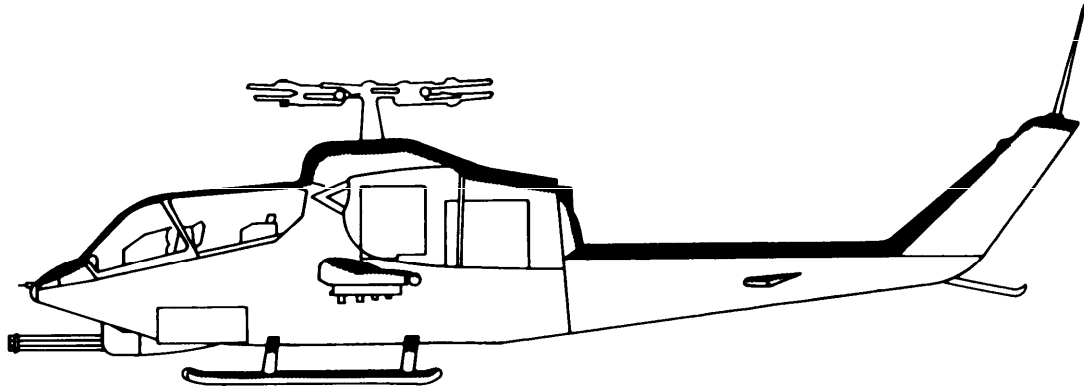


FIGURE E-13. SH-3D/H tactical paint scheme - Continued.

MIL-STD-2161A(AS)



■ 35237

□ 36375

FIGURE E-14. AH-1J/1T/1W tactical paint scheme.

MIL-STD-2161A(AS)

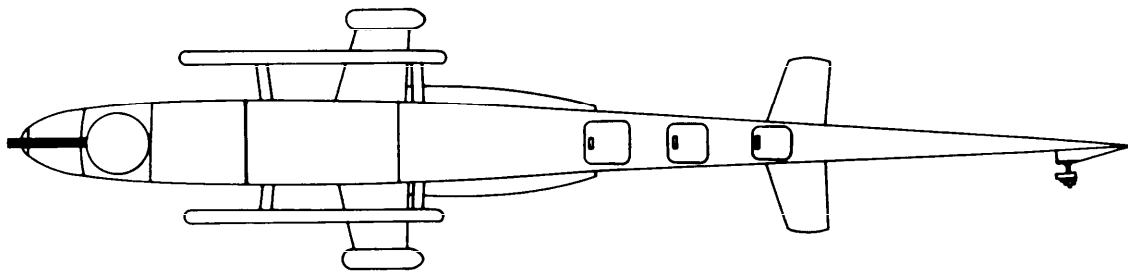
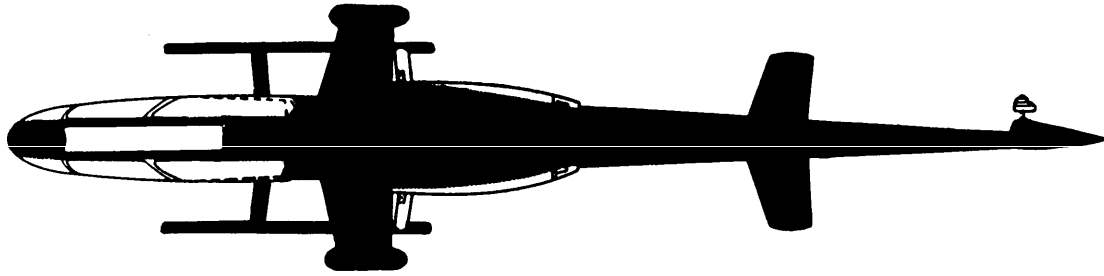


FIGURE E-14. AH-1J/1T/1W tactical paint scheme - Continued.

MIL-STD-2161A(AS)

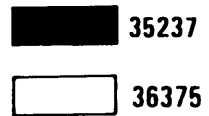
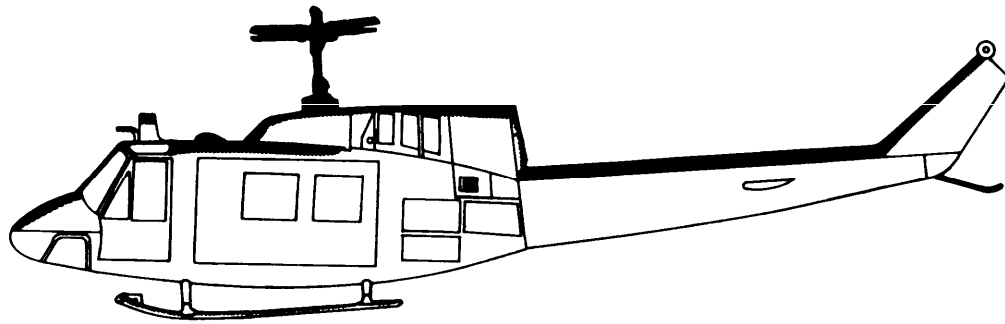


FIGURE E-15. UH-1N tactical paint scheme.

MIL-STD-2161A(AS)

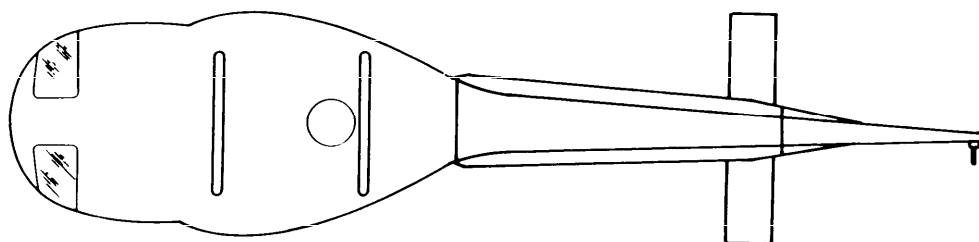
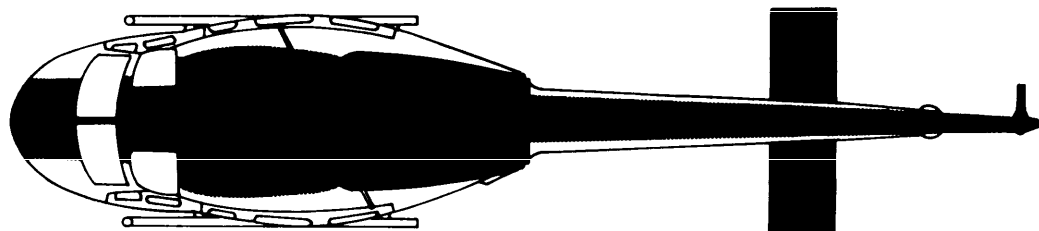


FIGURE E-15. UH-1N tactical paint scheme - Continued.

MIL-STD-2161A(AS)

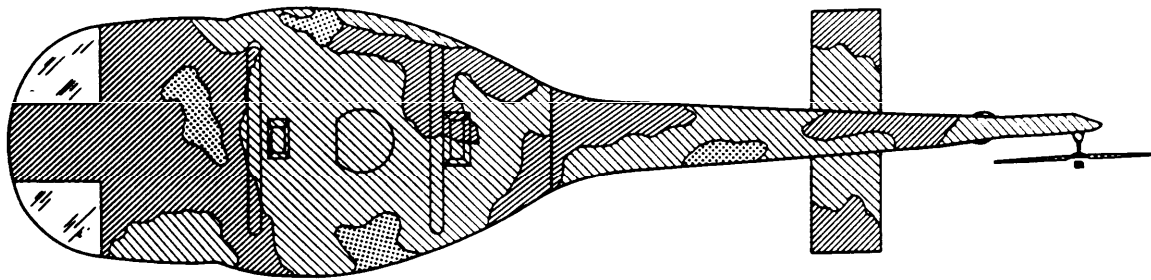


FIGURE E-16. HH-1K land camouflage paint scheme.

MIL-STD-2161A(AS)

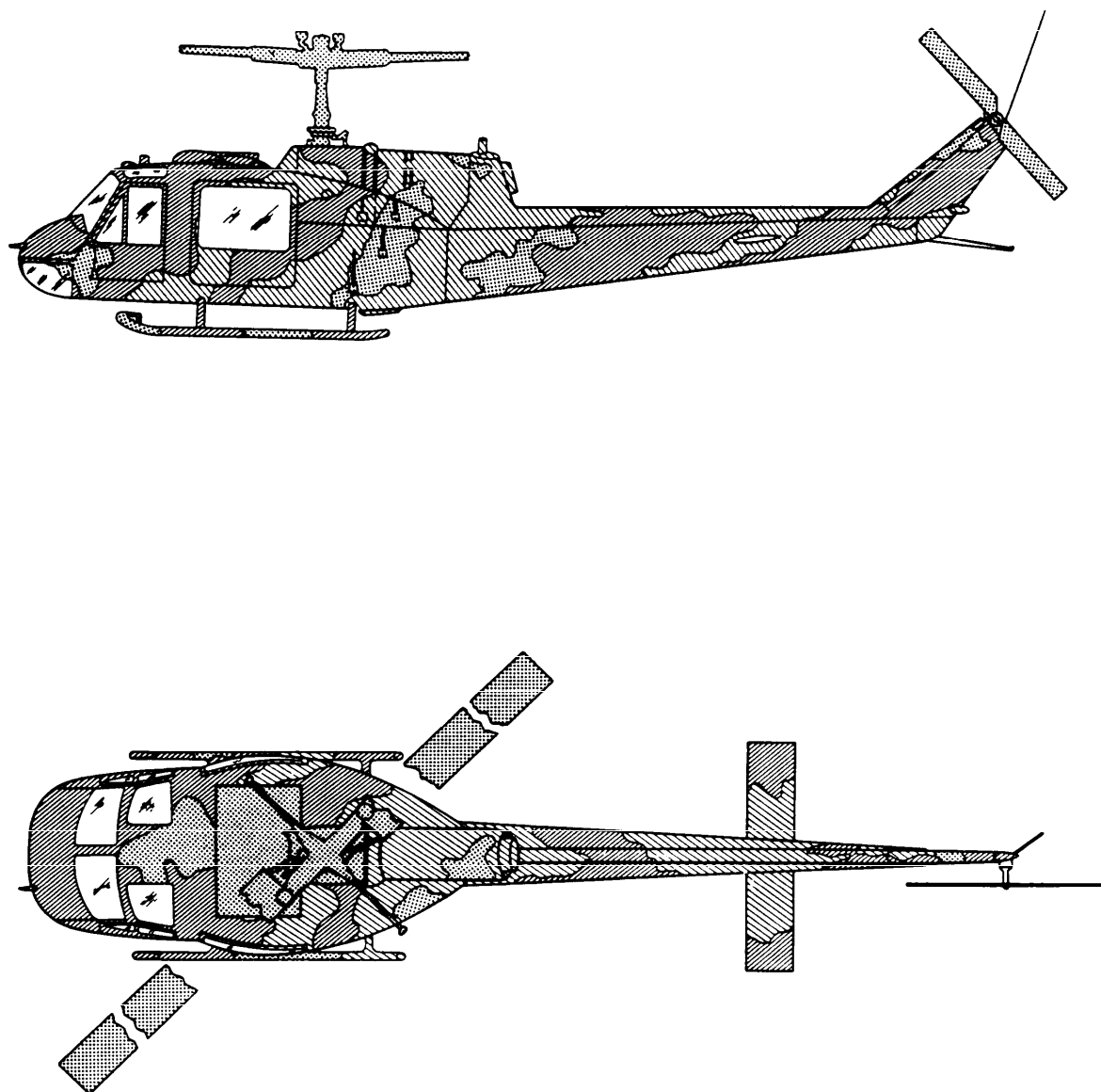


FIGURE E-16. HH-1K land camouflage paint scheme - Continued.

MIL-STD-2161A(AS)

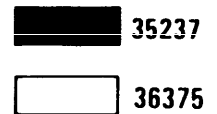
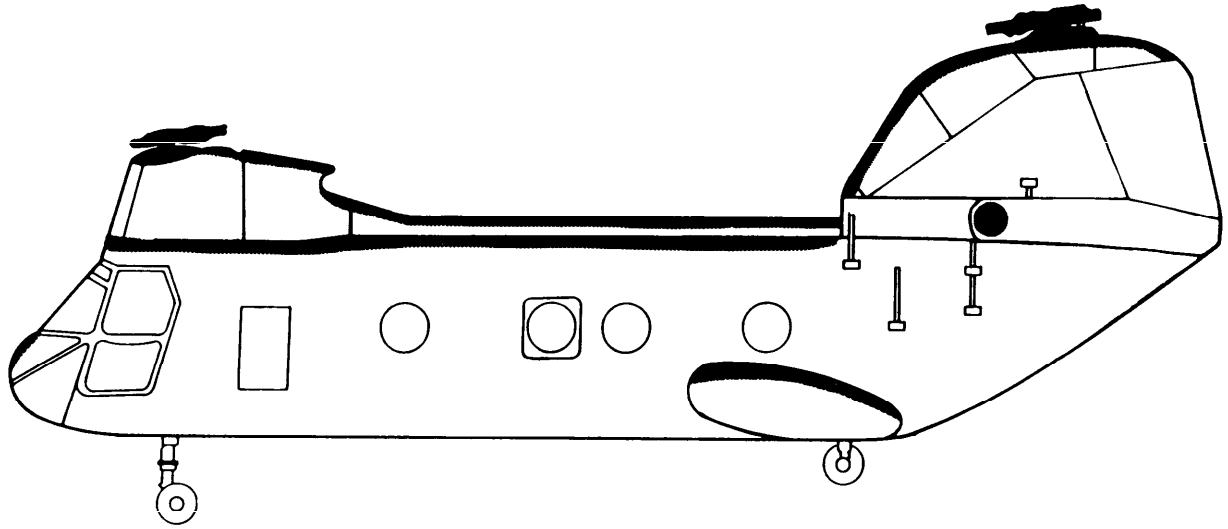


FIGURE E-17. CH-46E tactical paint scheme.

MIL-STD-2161A(AS)

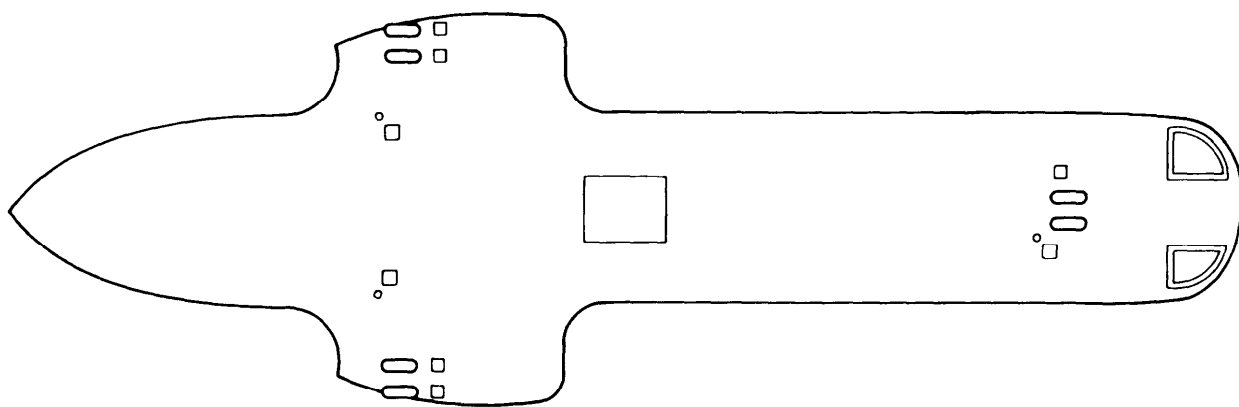
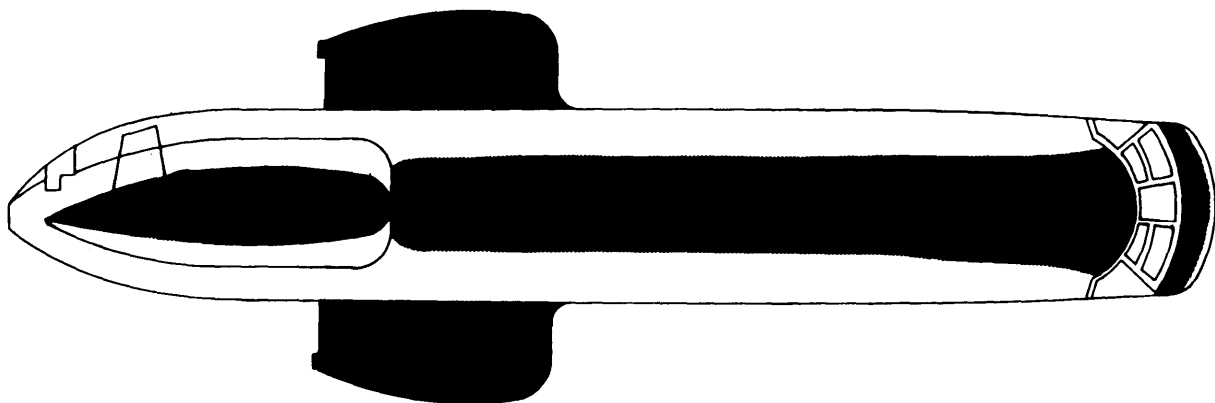


FIGURE E-17. CH-46E tactical paint scheme - Continued.

MIL-STD-2161A(AS)

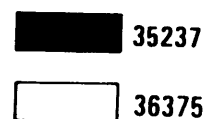
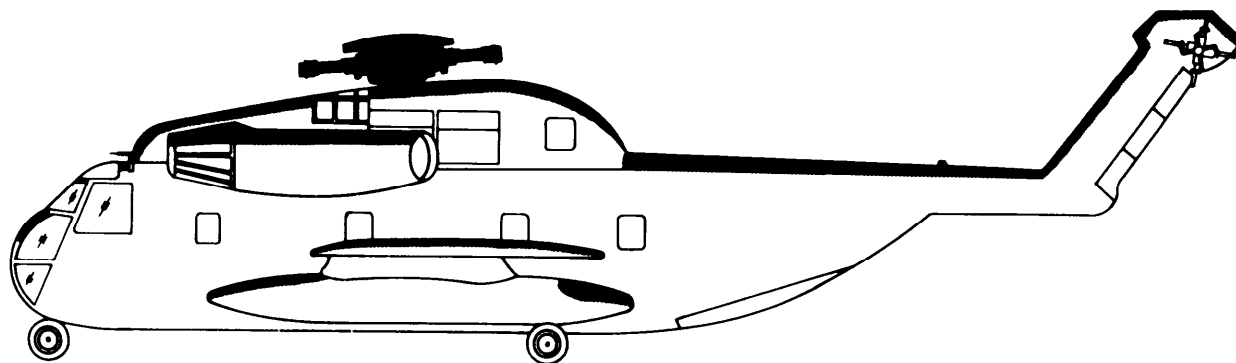


FIGURE E-18. CH-53D/RH-53D tactical paint scheme.

MIL-STD-2161A(AS)

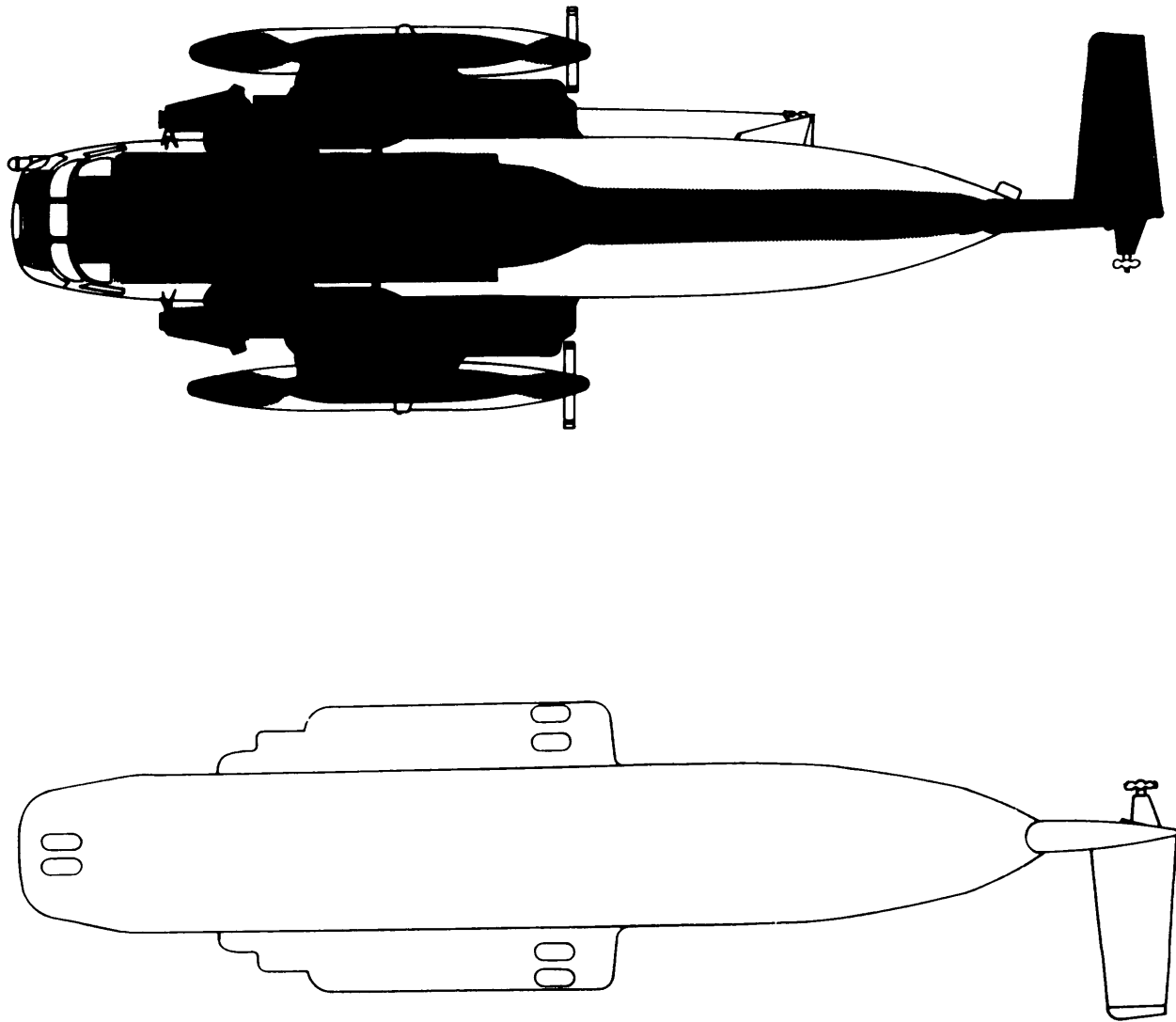


FIGURE E-18. CH-53D/RH-53D tactical paint scheme - Continued.

MIL-STD-2161A(AS)

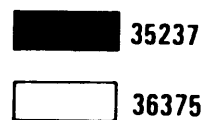
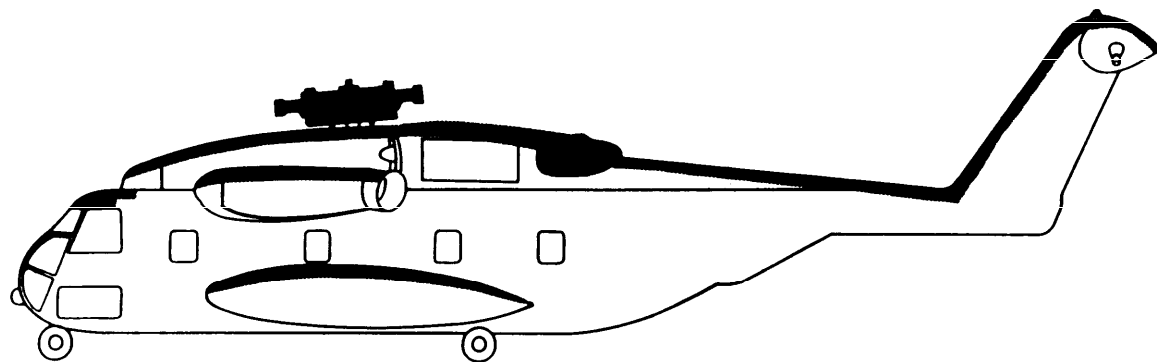


FIGURE E-19. CH-53E tactical paint scheme.

MIL-STD-2161A(AS)

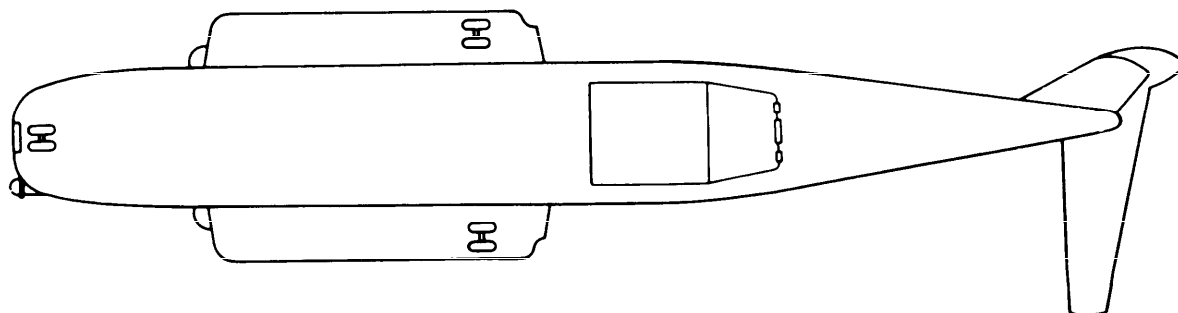
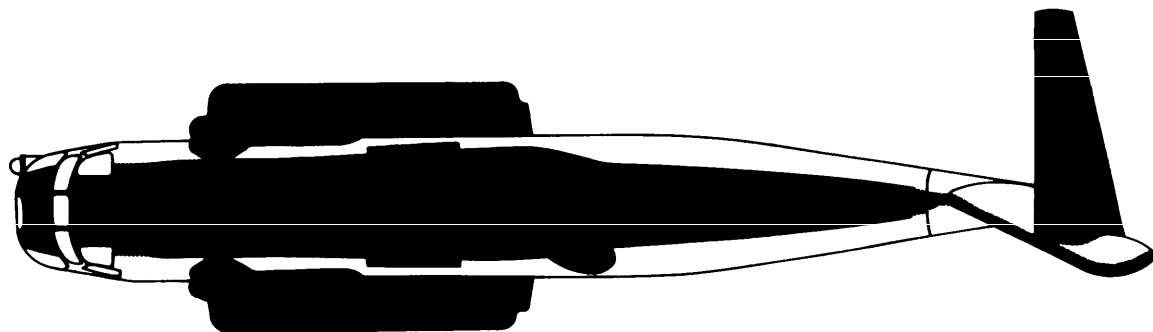


FIGURE E-19. CH-53E tactical paint scheme - Continued.

MIL-STD-2161A(AS)

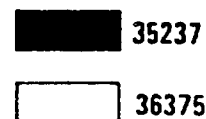
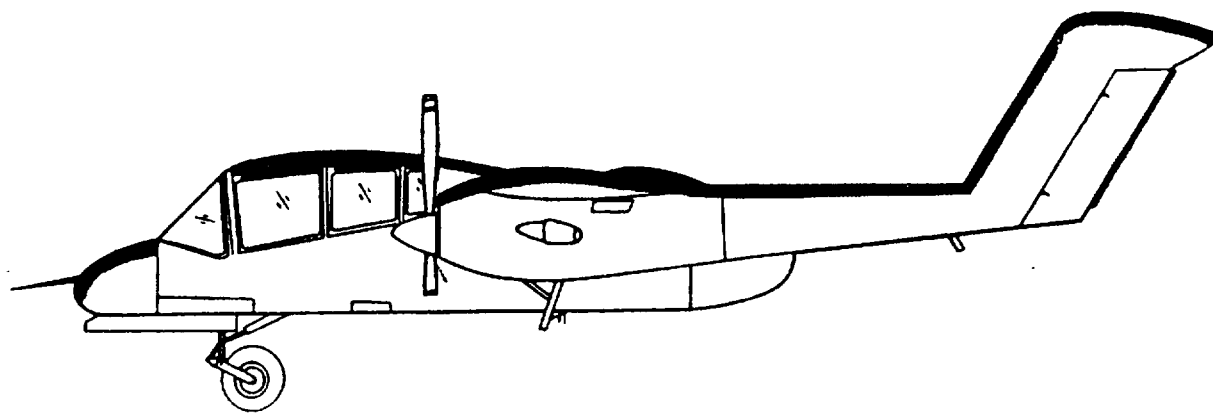


FIGURE E-20. OV-10A tactical paint scheme.

MIL-STD-2161A(AS)

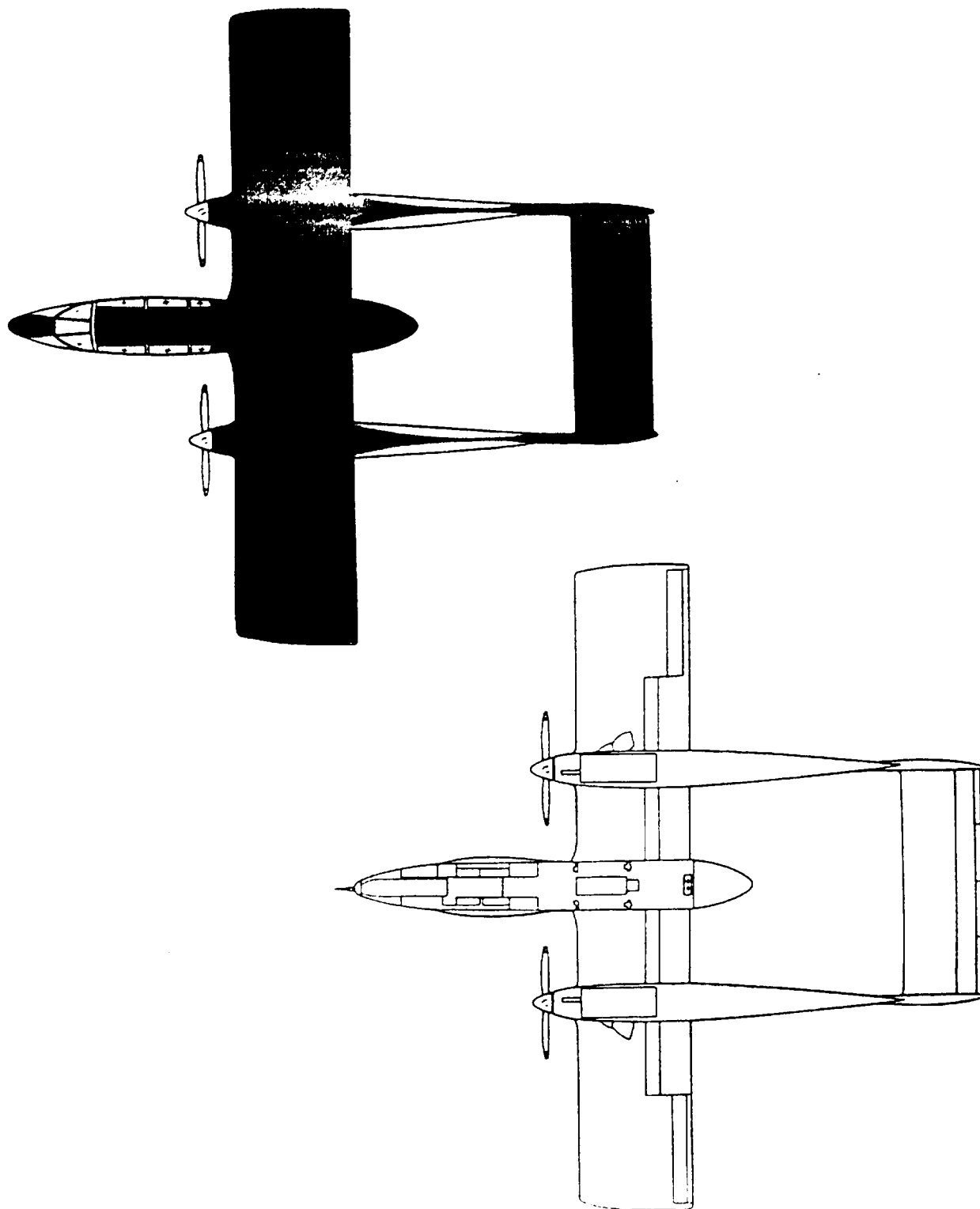


FIGURE E-20. OV-10A tactical paint scheme - Continued.

MIL-STD-2161A(AS)

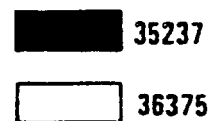
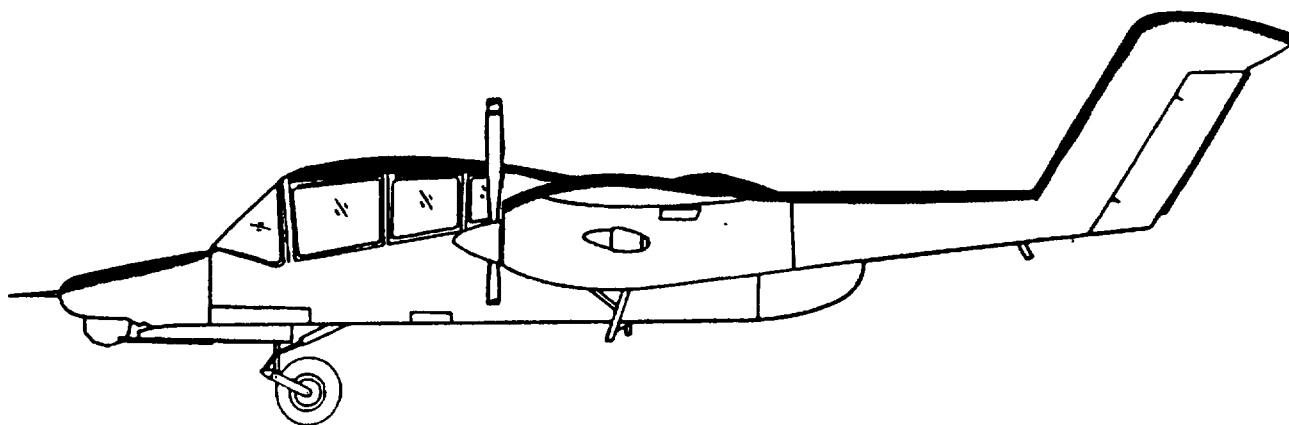


FIGURE E-21. OV-10D tactical paint scheme.

MIL-STD-2161A(AS)

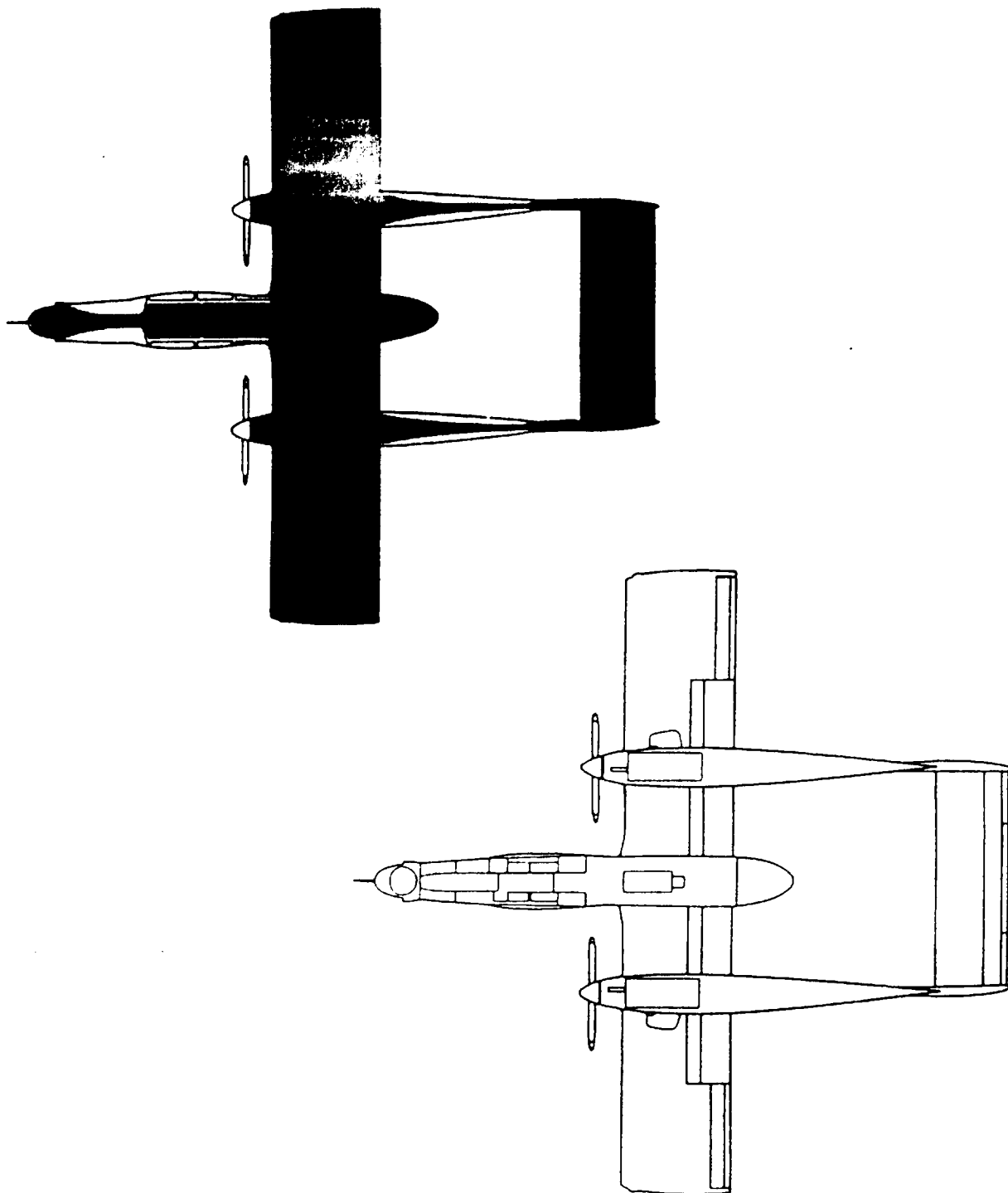


FIGURE E-21. OV-10D tactical paint scheme - Continued.

MIL-STD-2161A(AS)

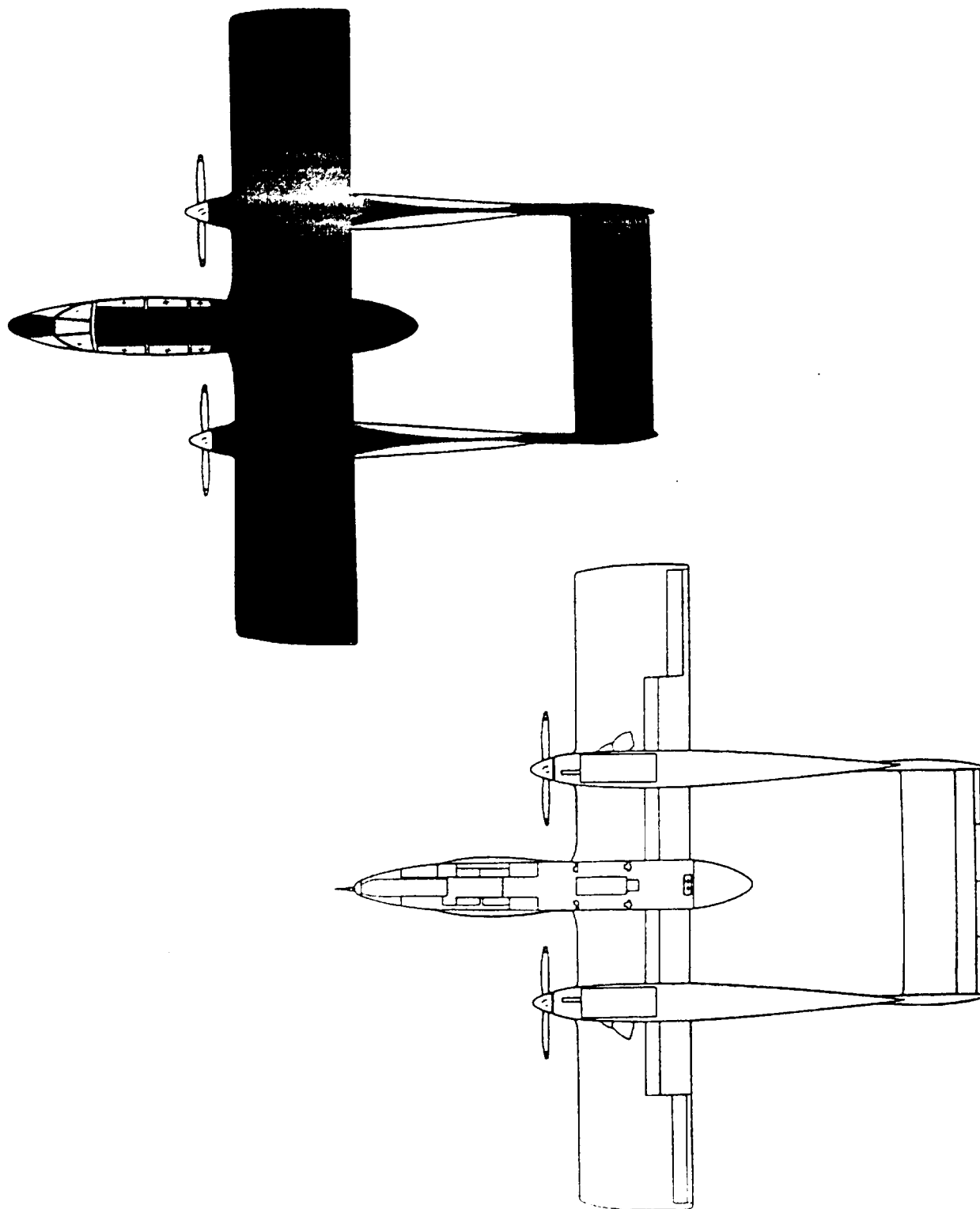


FIGURE E-20. OV-10A tactical paint scheme - Continued.

MIL-STD-2161A(AS)

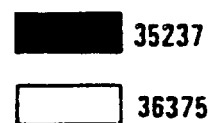
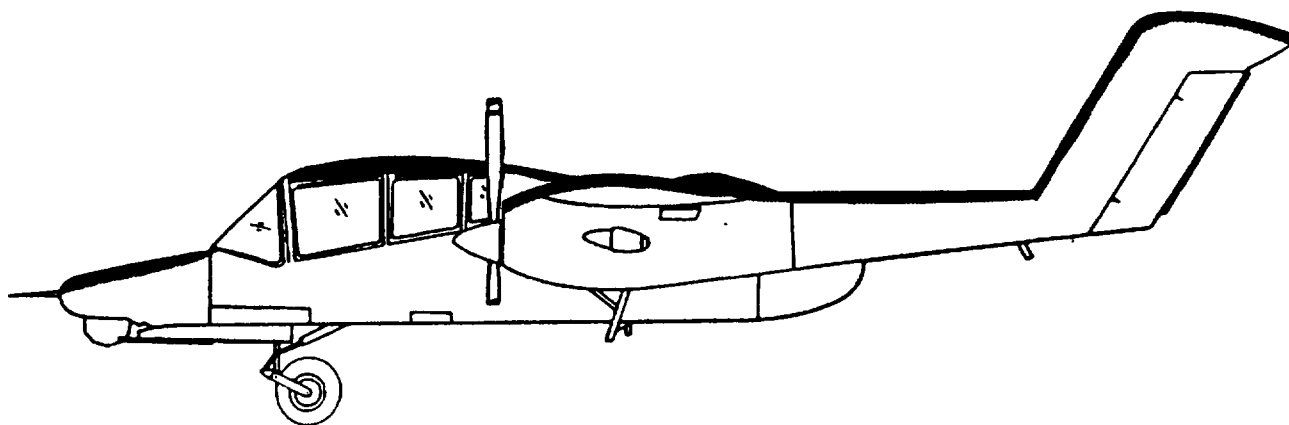


FIGURE E-21. OV-10D tactical paint scheme.

MIL-STD-2161A(AS)

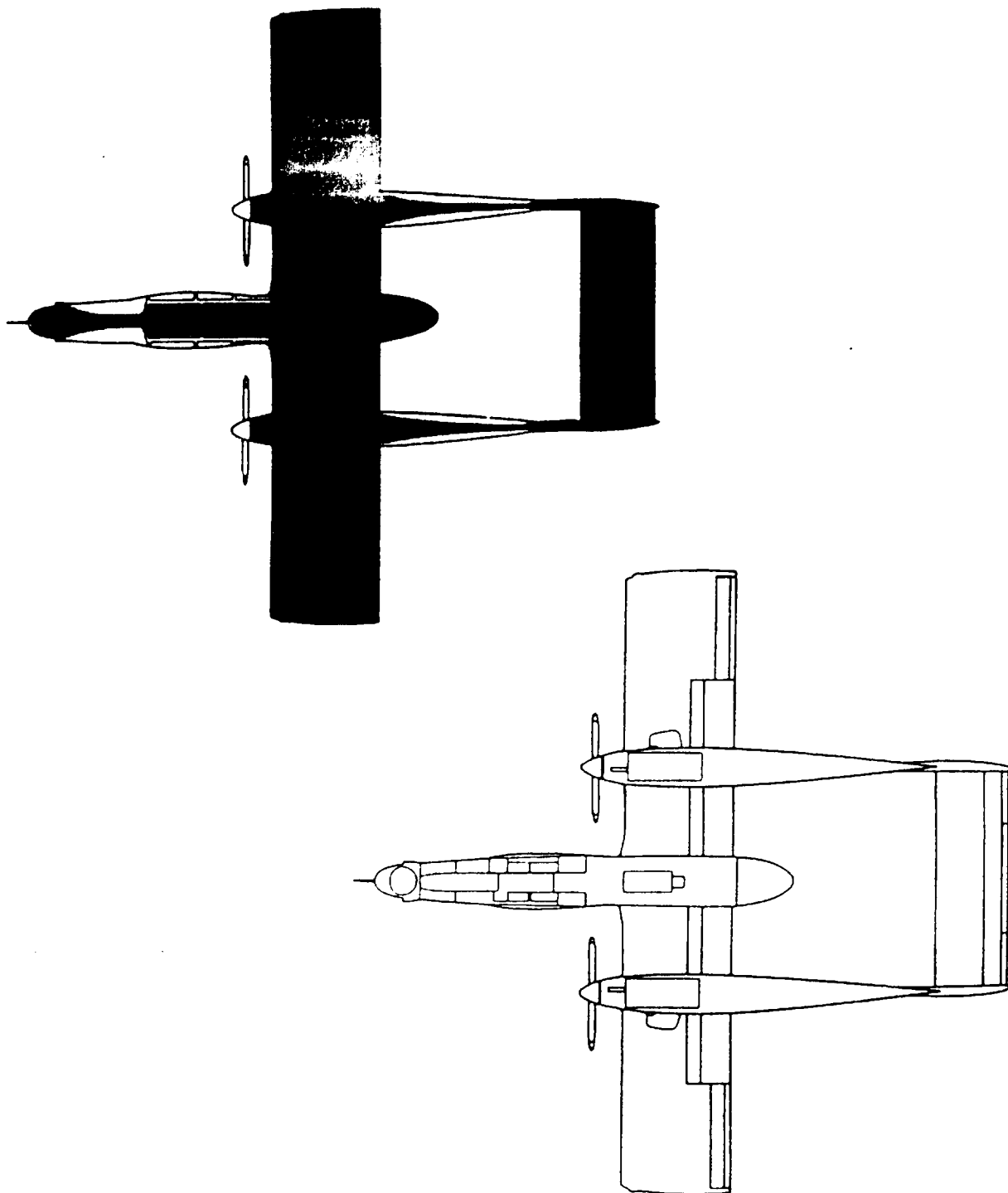


FIGURE E-21. OV-10D tactical paint scheme - Continued.

MIL-STD-2161A(AS)

APPENDIX F

NATIONAL INSIGNIAS FOR FOREIGN AIRCRAFT

10. SCOPE

10.1 Scope. This Appendix illustrates insignias of foreign countries.

10.2 Use. This Appendix is a mandatory part of this standard. The information contained herein is intended for compliance.

20. APPLICABLE DOCUMENTS. This section is not applicable to this Appendix.

30. DEFINITIONS

30.1 Definitions. For purposes of this Appendix, the definitions of this standard shall apply.

40. GENERAL REQUIREMENTS

40.1 Foreign country national insignias. The following figures illustrate national insignias for foreign countries.

MIL-STD-2161A(AS)

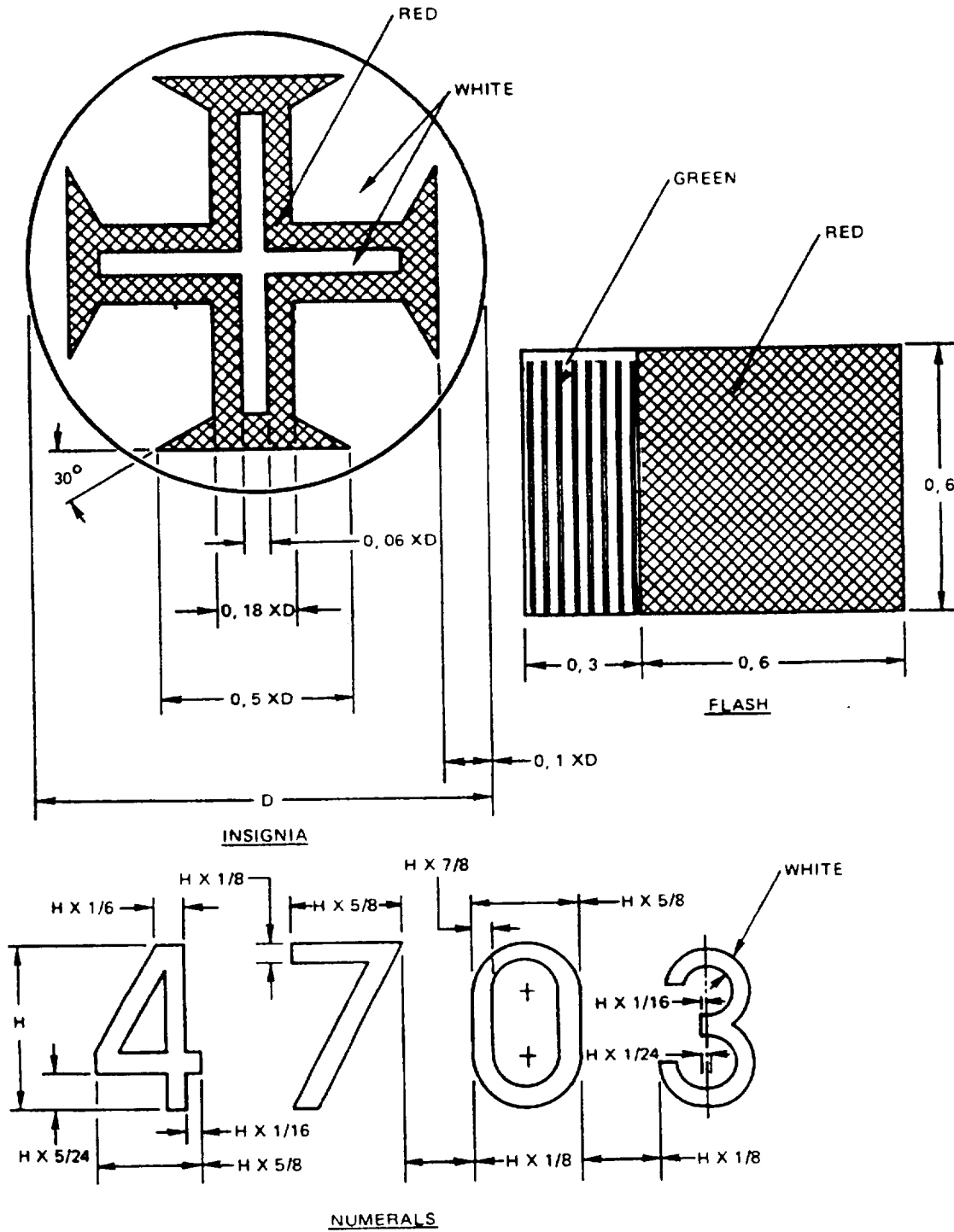


FIGURE F-1. National insignia of Portugal (flash and numerals).

MIL-STD-2161A(AS)

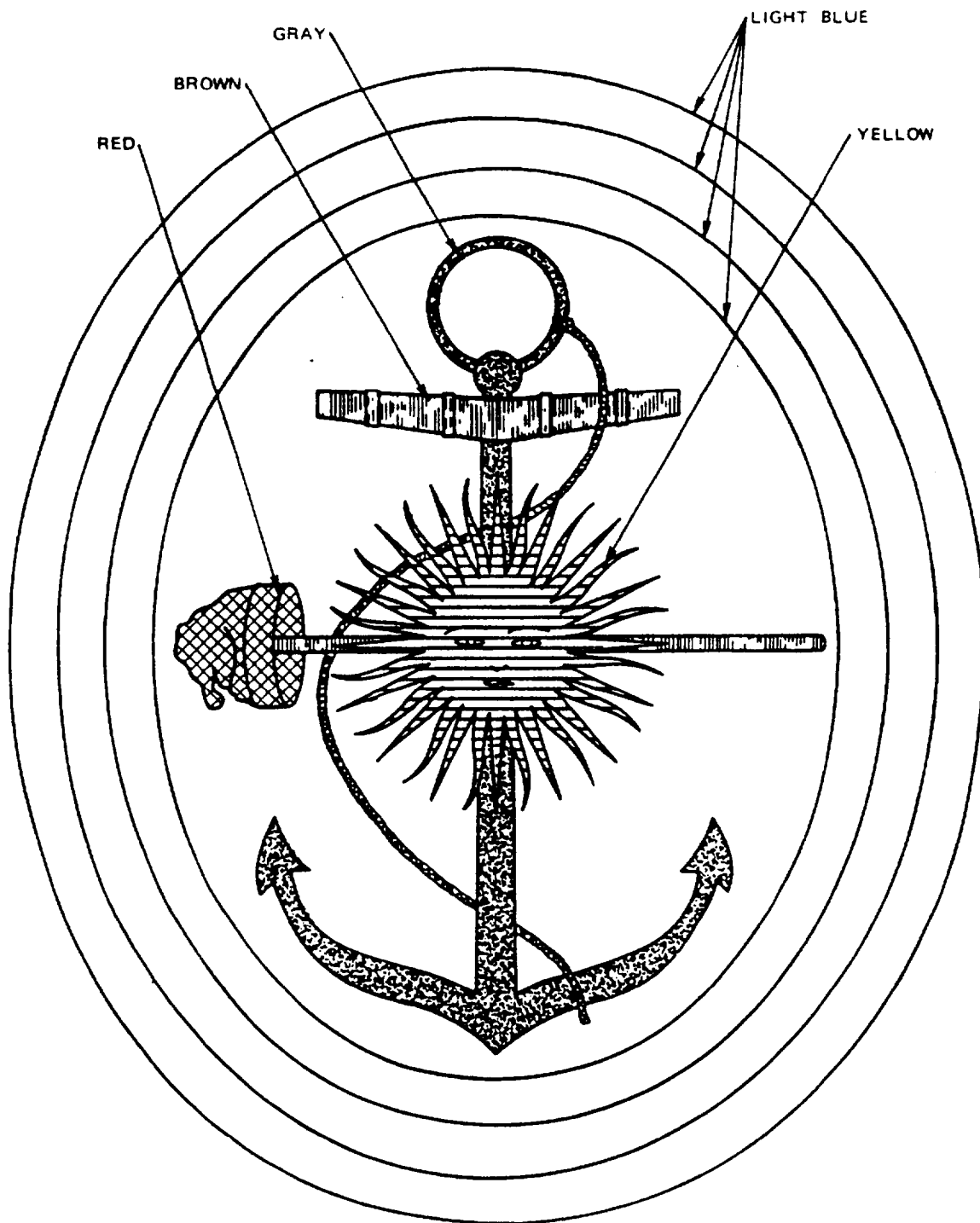


FIGURE F-2. National insignia of Argentina.

MIL-STD-2161A(AS)

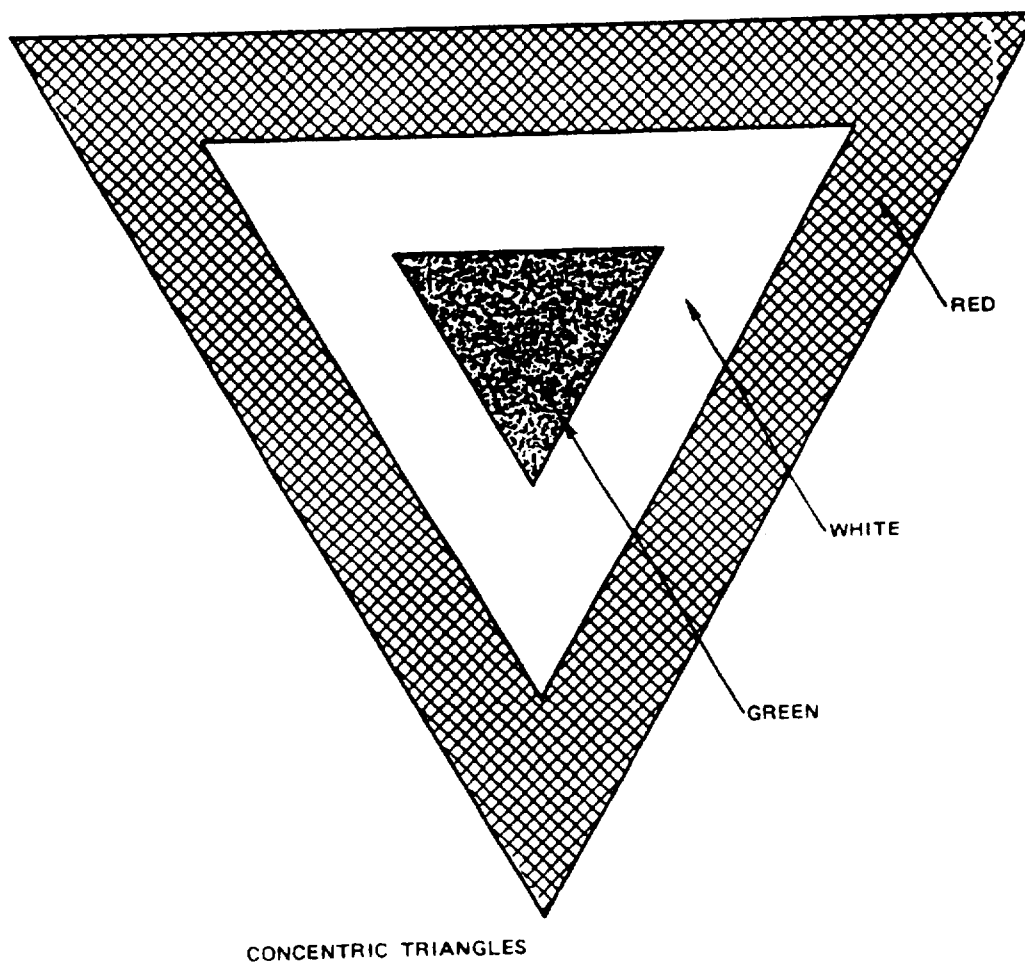
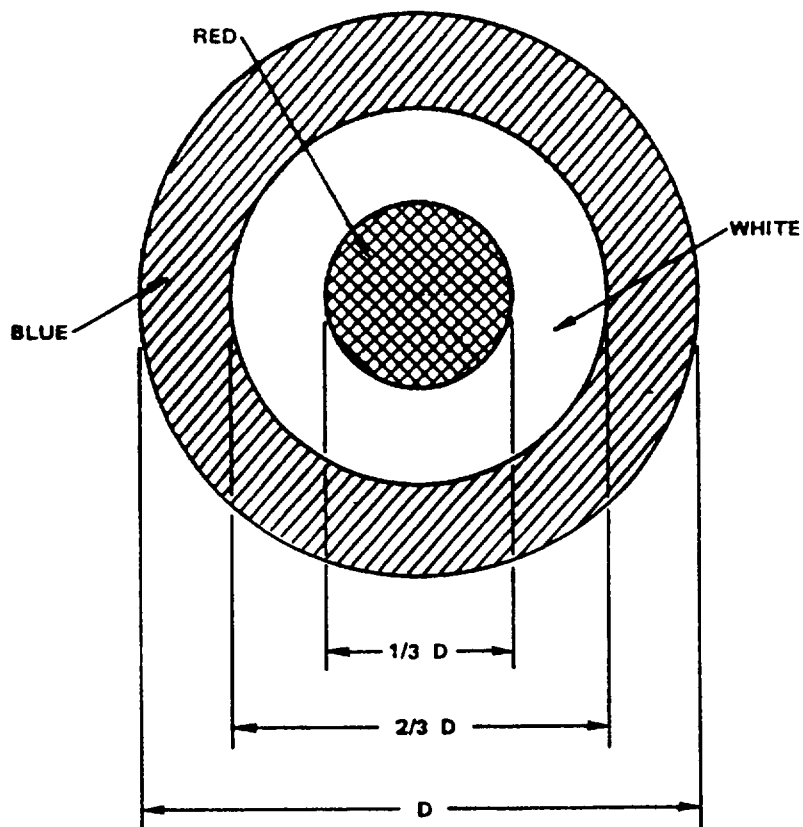


FIGURE F-3. National insignia of Mexico (flash).

MIL-STD-2161A(AS)

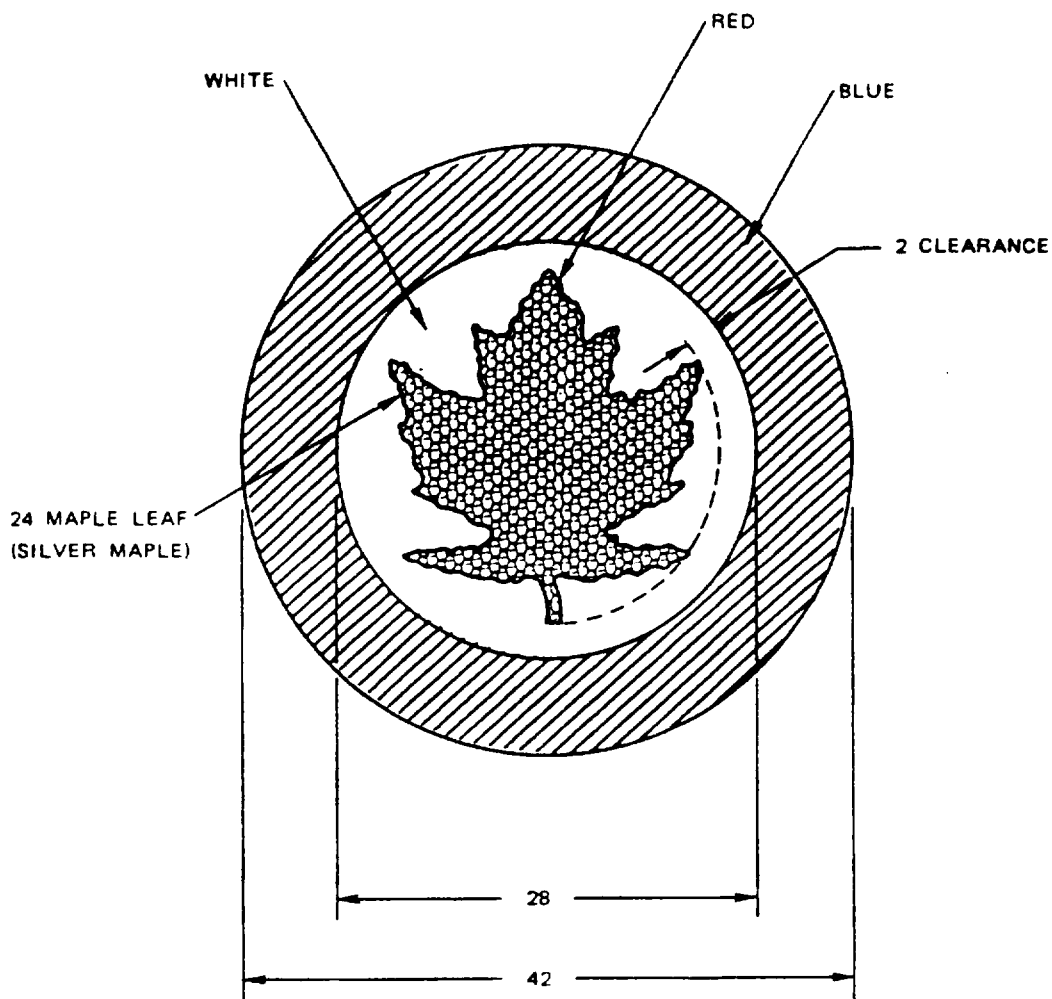


SIZE	D
SMALL	2 FT 6 IN.
MEDIUM	2 FT 8 IN.
LARGE	3 FT

DIMENSIONS IN INCHES:

FIGURE F-4. National insignia of Great Britain.

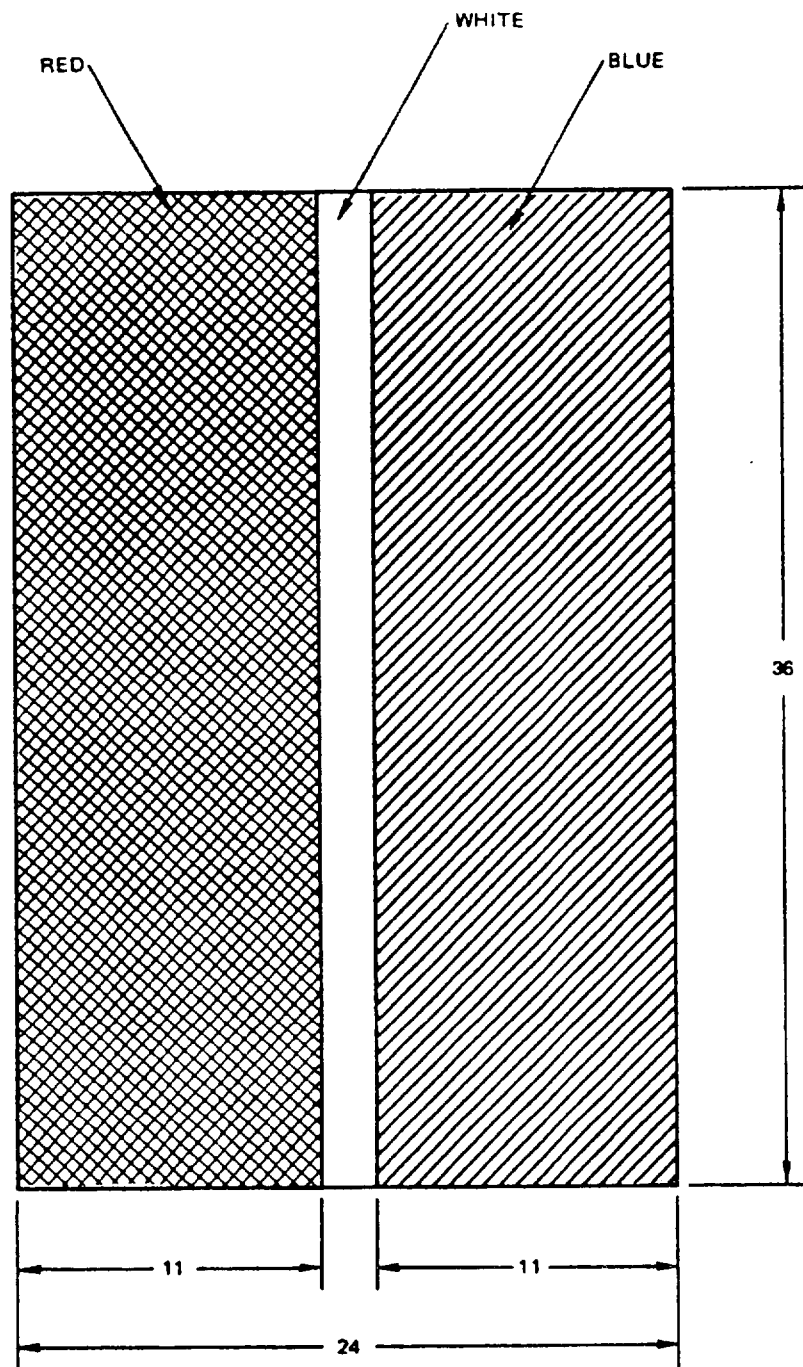
MIL-STD-2161A(AS)



DIMENSIONS IN INCHES

FIGURE F-5. National insignia of Canada (roundel) marking I.

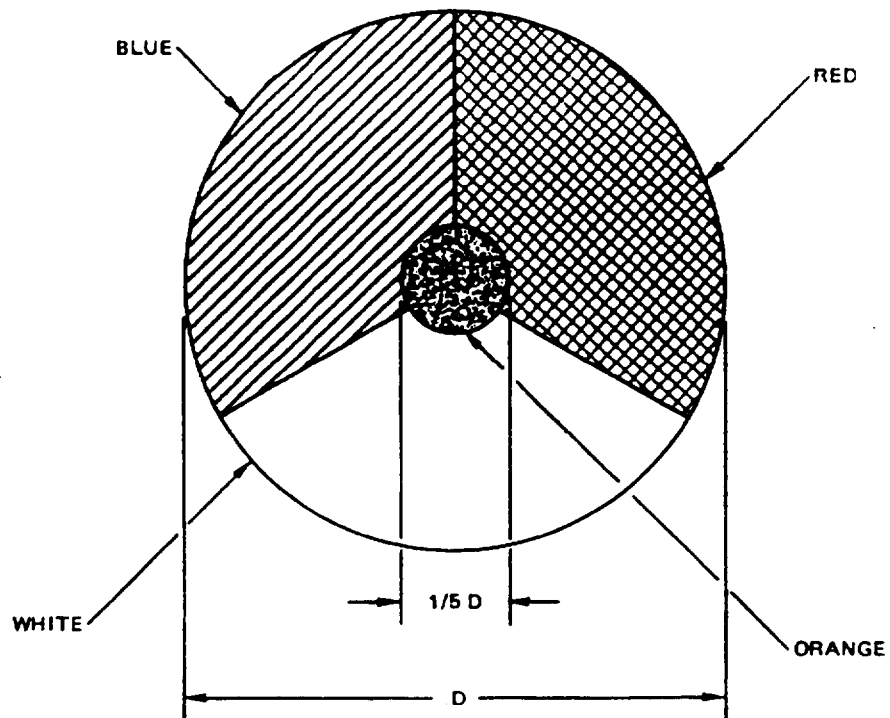
MIL-STD-2161A(AS)



DIMENSIONS IN INCHES

FIGURE F-6. National insignia of Canada (flash) marking II.

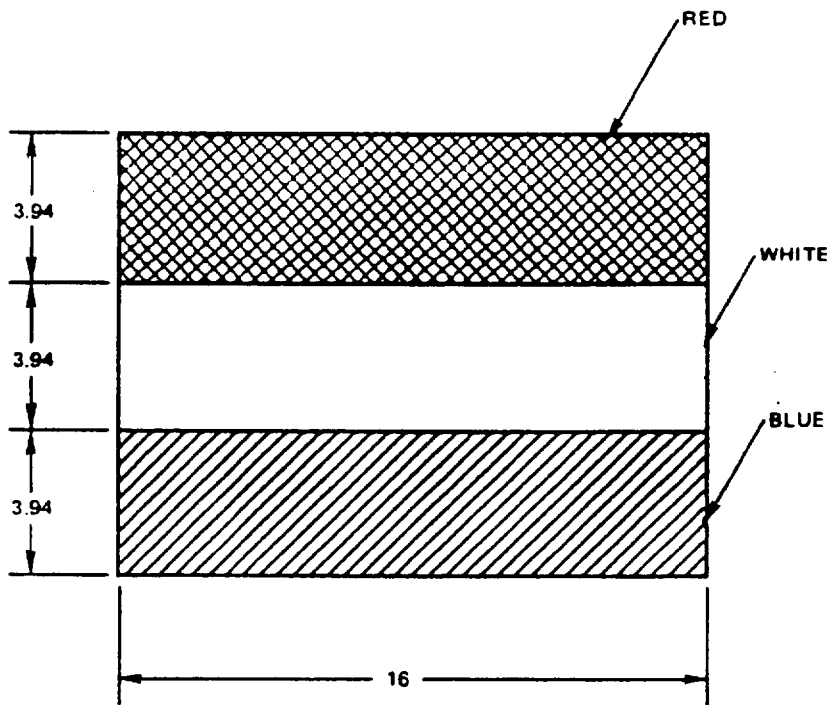
MIL-STD-2161A(AS)



DIMENSIONS IN INCHES:

FIGURE F-7. National insignia of Netherlands (roundel) marking I.

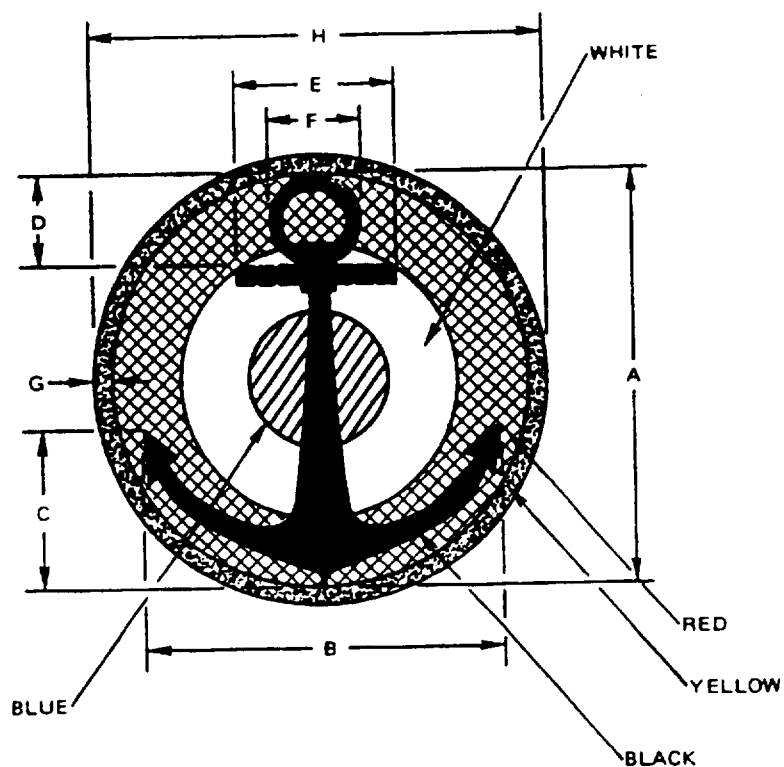
MIL-STD-2161A(AS)



DIMENSIONS IN INCHES

FIGURE F-8. National insignia of Netherlands (flash) marking II.

MIL-STD-2161A(AS)

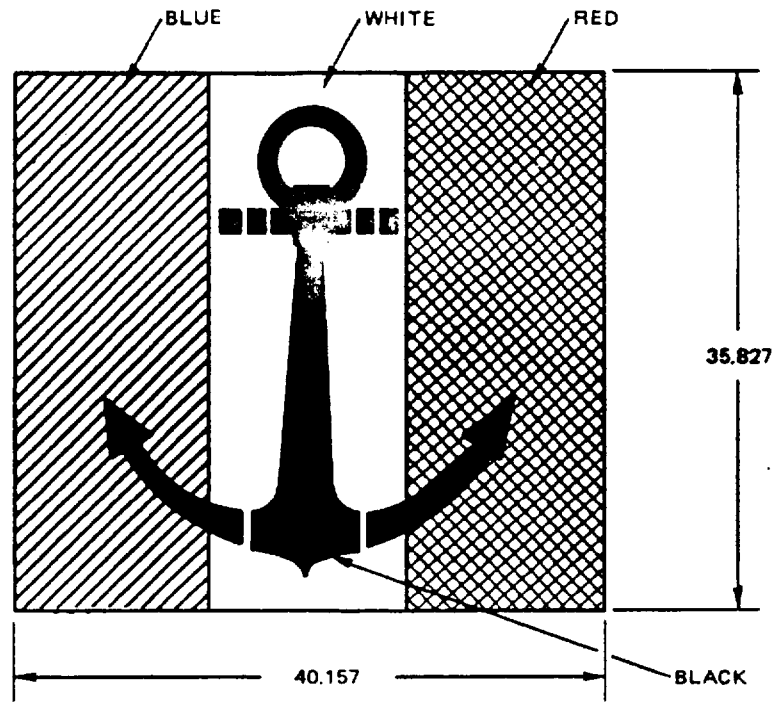


A DIA	B	C	D	E	F DIA	G	H DIA
23.622 (60 CM)	20.6692	8.8582	5.315	20.6692	4.7244	1.1811	25.9842
27.559 (70 CM)	24.0942	10.3149	6.181	24.0942	5.5118	1.1811	29.9212
31.496 (80 CM)	27.559	11.811	7.0866	11.811	6.2992	1.1811	33.8582

DIMENSIONS IN INCHES

FIGURE F-9. National insignia of France (cocarde) marking I (anchor superimposed when planes are intended for French Navy.

MIL-STD-2161A(AS)



DIMENSIONS IN INCHES

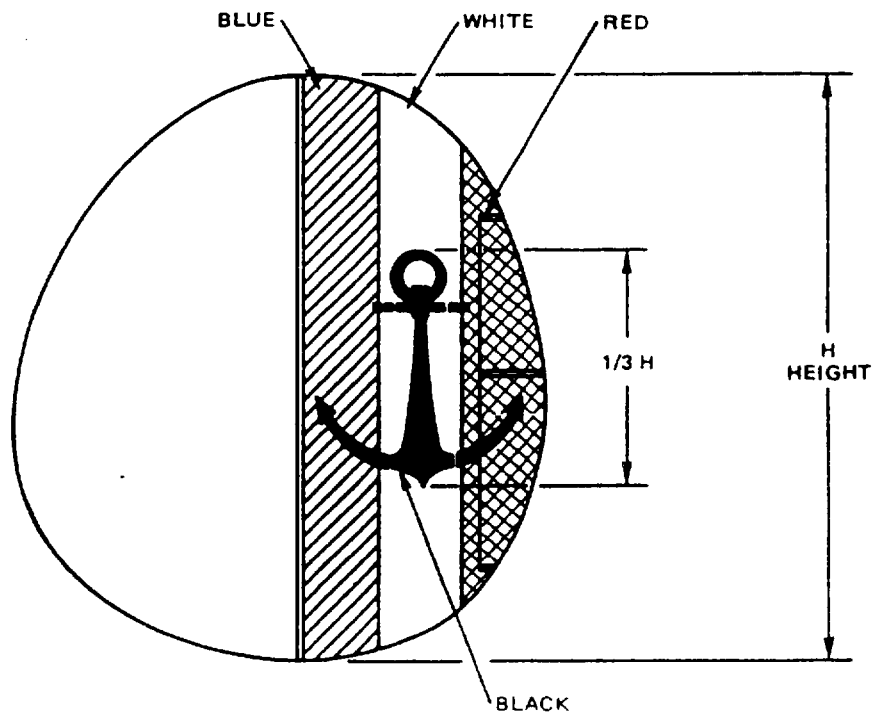
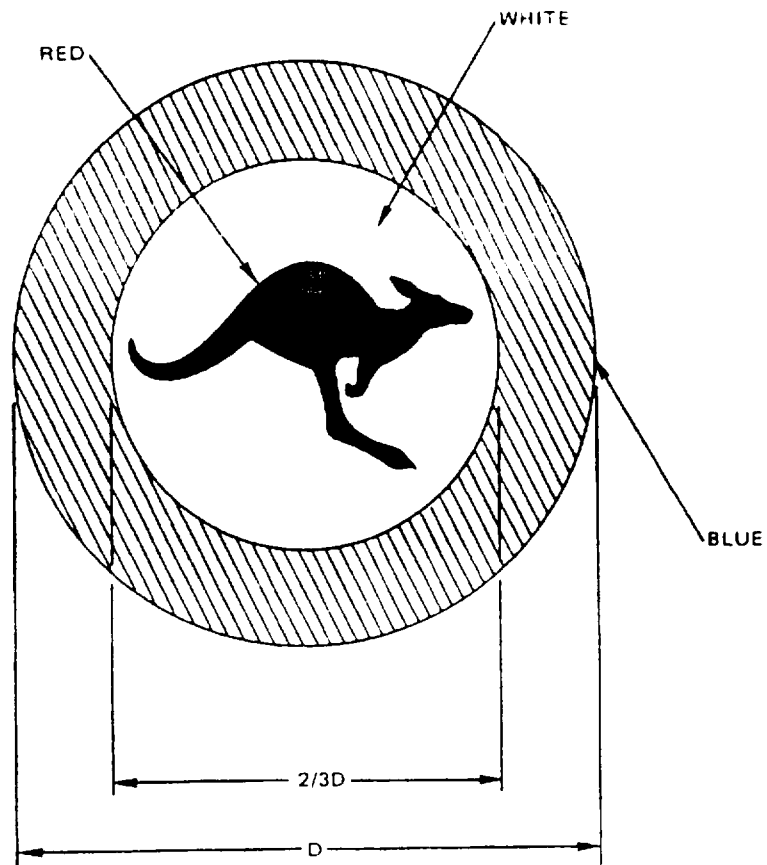


FIGURE F-10. National insignia of France (flash) marking II.

MIL-STD-2161A(AS)

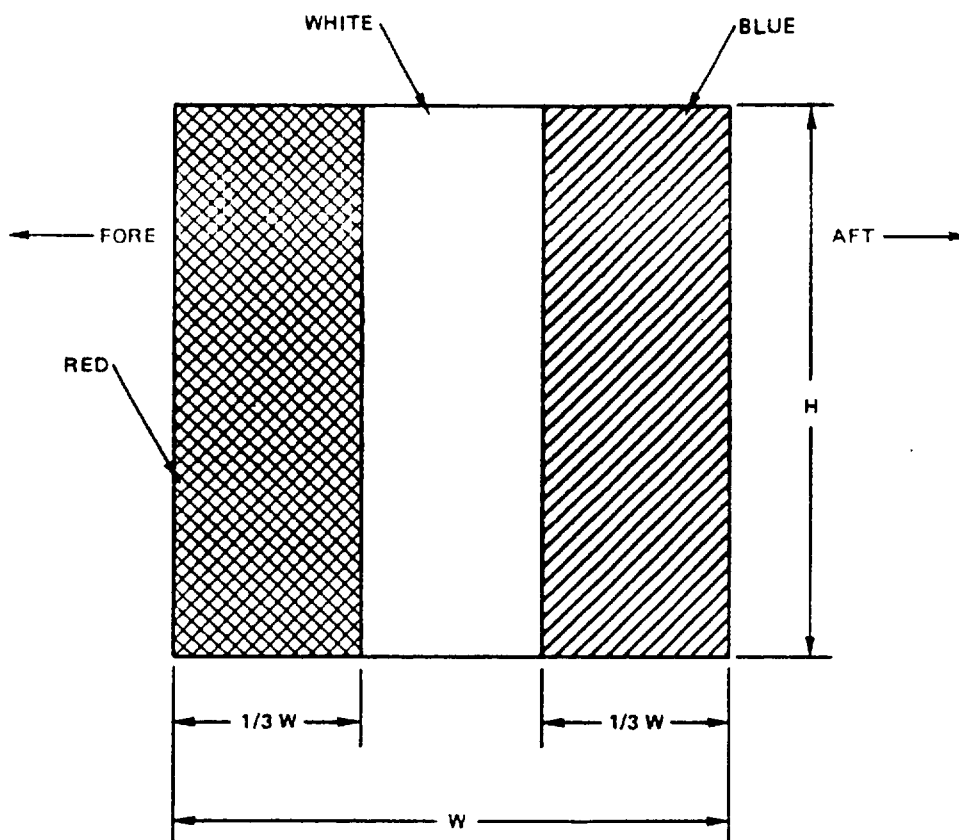


TYPE OF FUSELAGE		D
SMALL	TRAINER OR BOOM TYPE FUSELAGE	16 1/2
MEDIUM	AND FIGHTER AIRCRAFT	33
LARGE	TRANSPORT AND HEAVY BOMBERS	48

DIMENSIONS IN INCHES

FIGURE F-11. National insignia of Australia (roundel) marking I.

MIL-STD-2161A(AS)



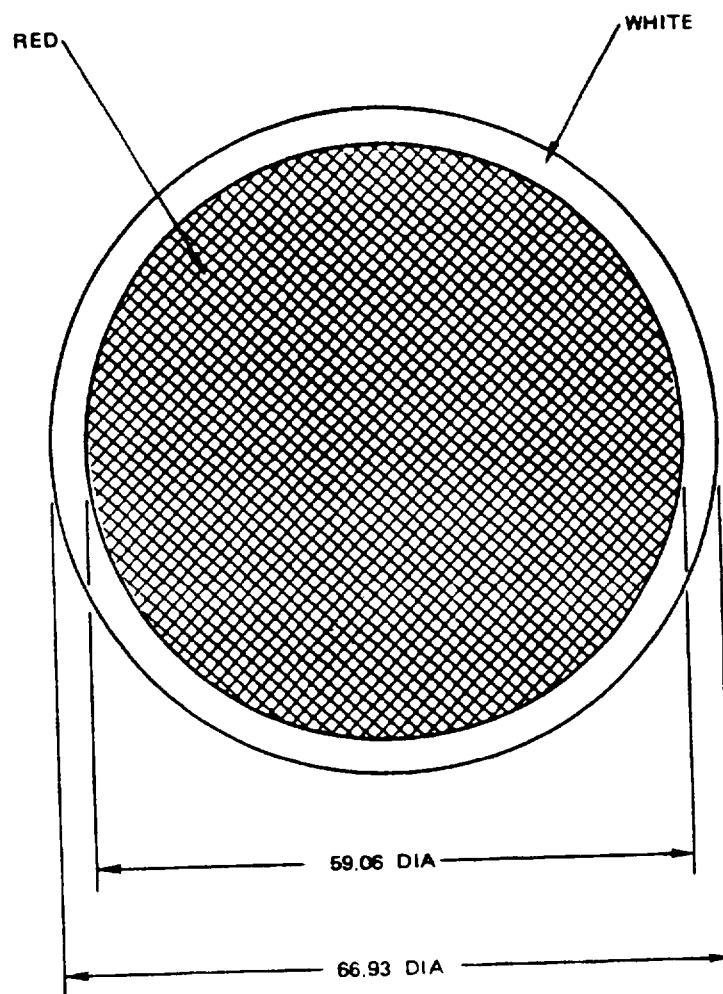
TABLE

OVERALL SIZE OF TAIL FIN FLASH		H HEIGHT	W WIDTH
SMALL:	TRAINING AIRCRAFT	18	16
MEDIUM:	AND FIGHTER AIRCRAFT	24	22
LARGE:	TRANSPORT HEAVY BOMBER	24	34

DIMENSIONS IN INCHES

FIGURE F-12. National insignia of Australia (flash) marking II.

MIL-STD-2161A(AS)

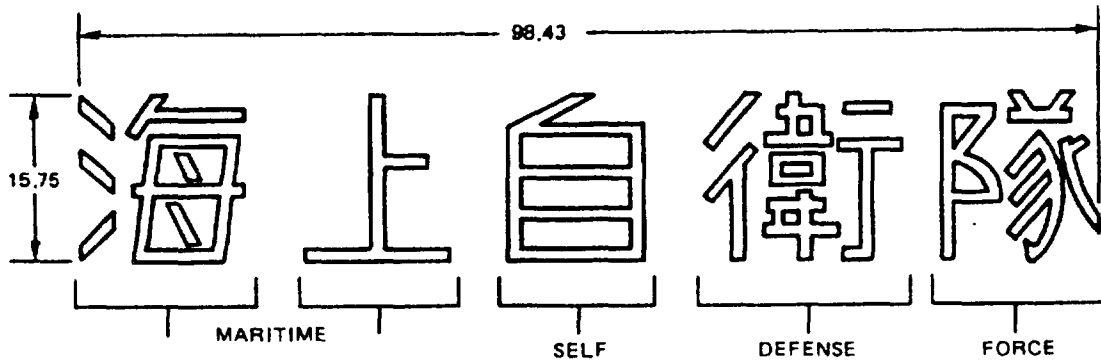


DIMENSIONS IN INCHES

FOR LARGE OR SMALLER AIRCRAFT, MARKINGS SHALL BE PROPORTIONATELY LARGER OR SMALLER AS APPLICABLE

FIGURE F-13. National insignia of Japan (roundel).

MIL-STD-2161A(AS)

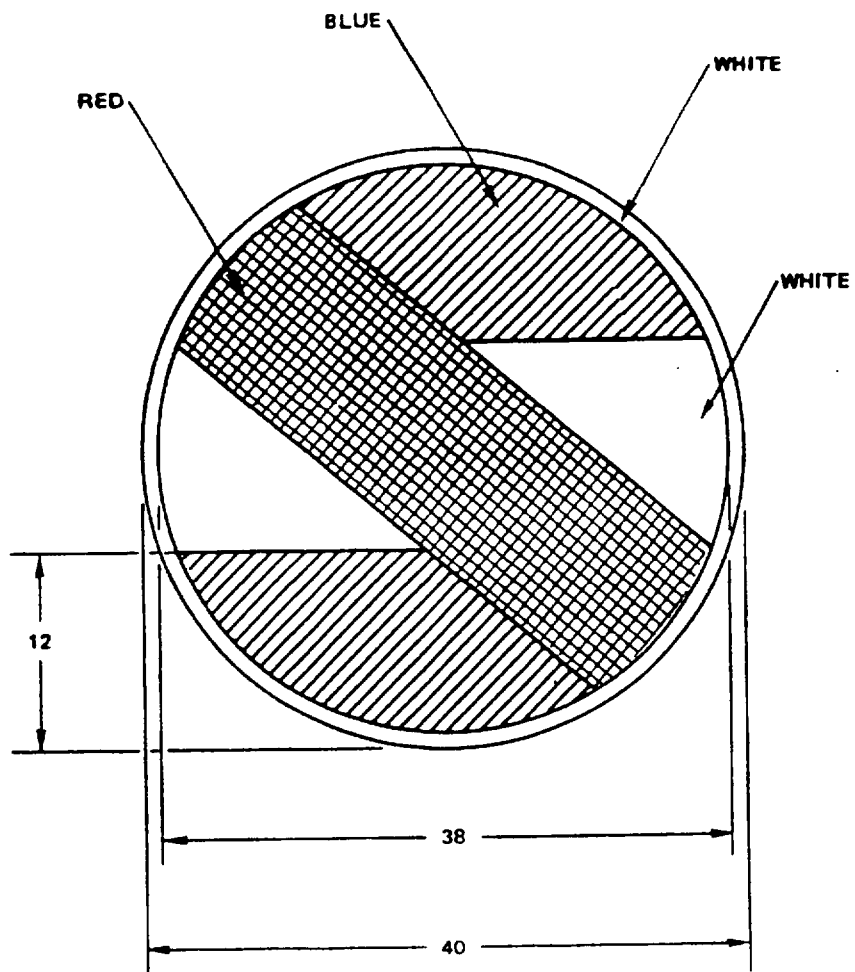


DIMENSIONS IN INCHES

FOR LARGER OR SMALLER AIRCRAFT, MARKINGS SHALL BE PROPORTIONATELY LARGER OR SMALLER AS APPLICABLE

FIGURE F-14. National insignia of Japan (kanji characters).

MIL-STD-2161A(AS)



FOR LARGER
AIRCRAFT INSIGNIA
SHALL BE
PROPORTIONATELY
LARGER.

DIMENSIONS IN INCHES

FIGURE F-15. National insignia of Uruguay (roundel).

MIL-STD-2161A(AS)

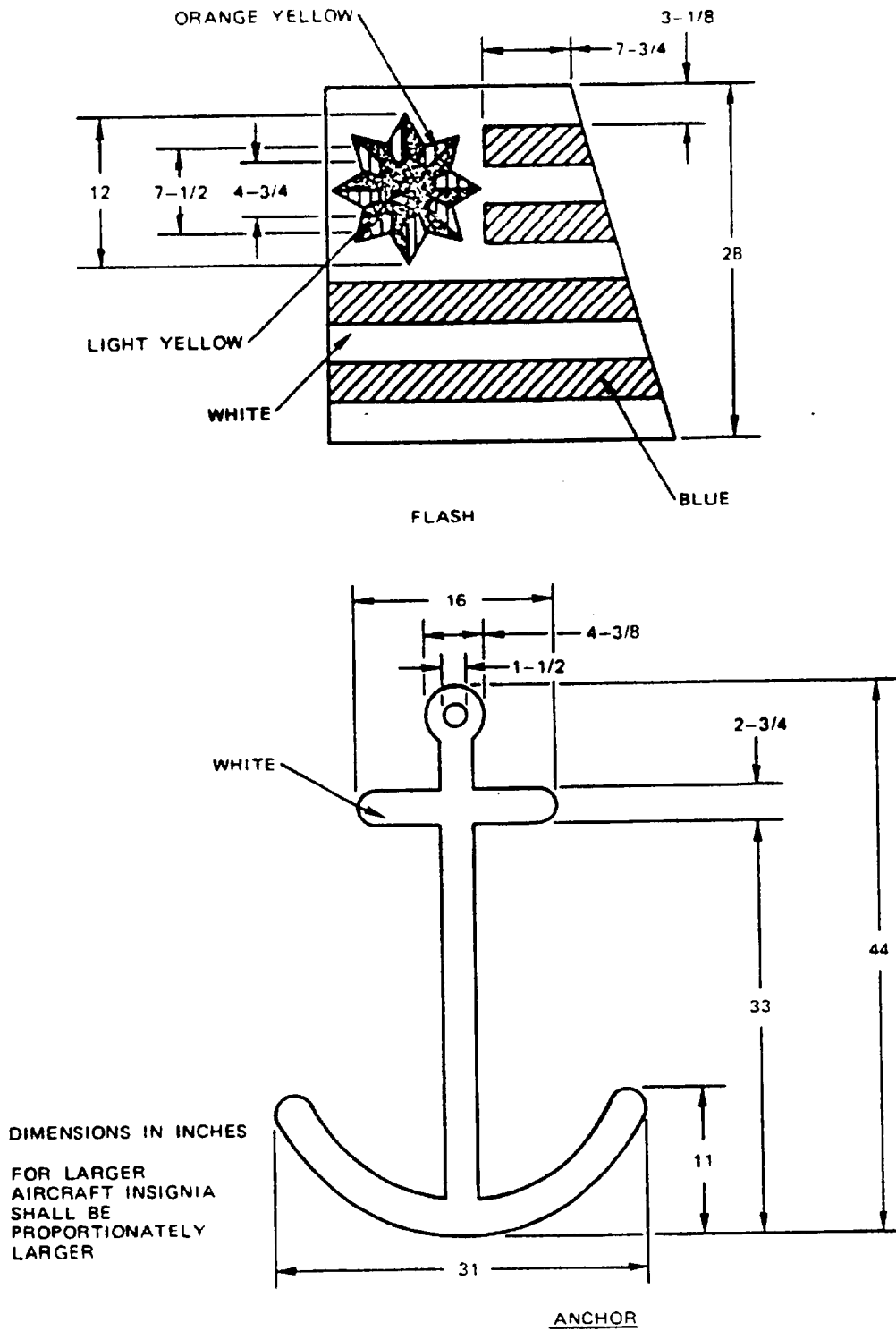


FIGURE F-16. National insignia of Uruguay.

MIL-STD-2161A(AS)

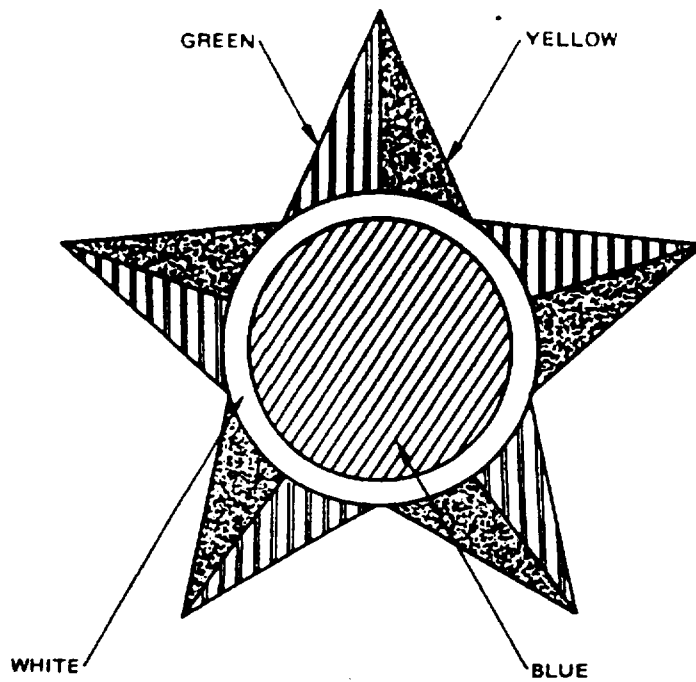


FIGURE F-17. National insignia of Brazil (star) marking I.

MIL-STD-2161A(AS)

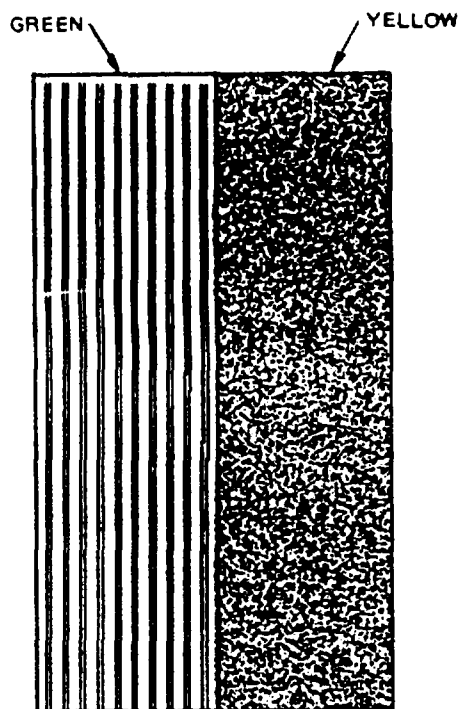


FIGURE F-18. National insignia of Brazil (flash) marking II.

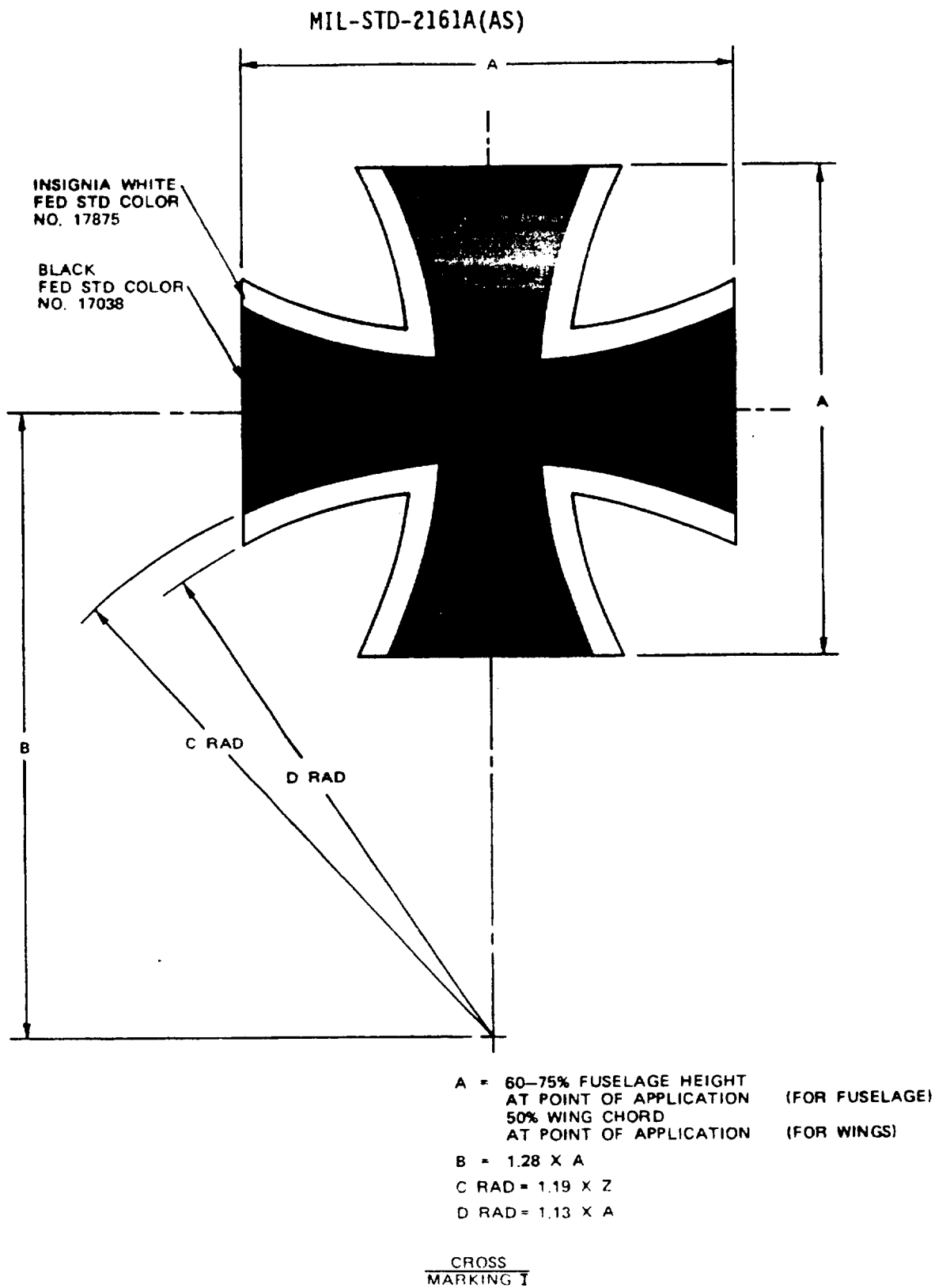
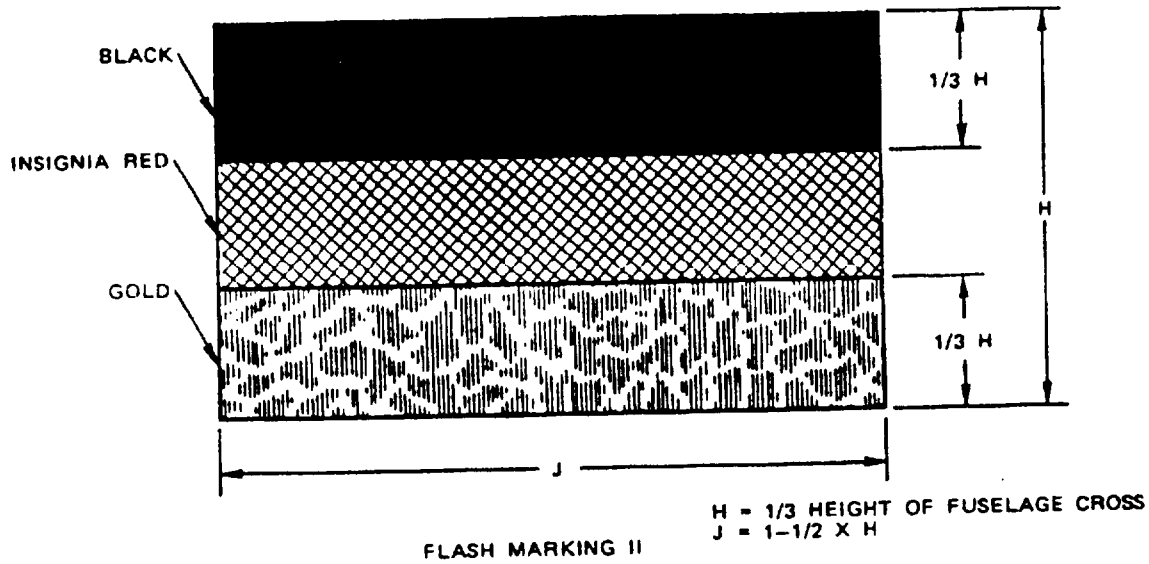


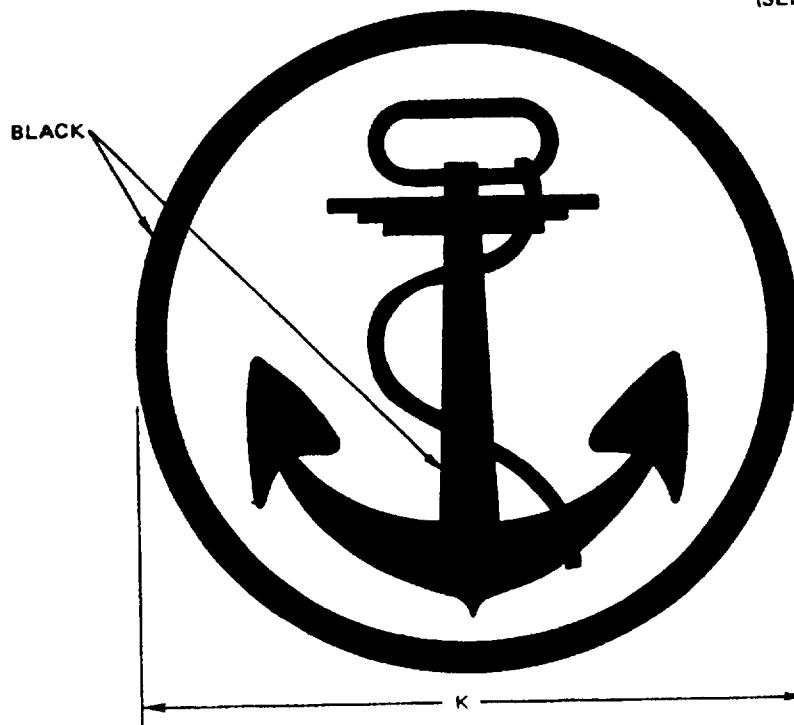
FIGURE F-19. National insignia of Federal Republic of Germany.

MIL-STD-2161A(AS)



FLASH MARKING II

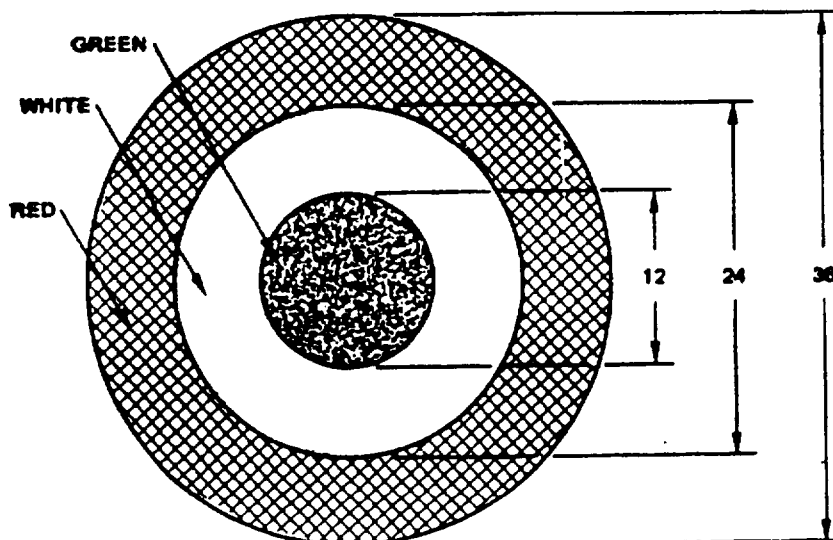
K = 1/2 WIDTH OF FUSELAGE CROSS
(SEE FIGURE 29)



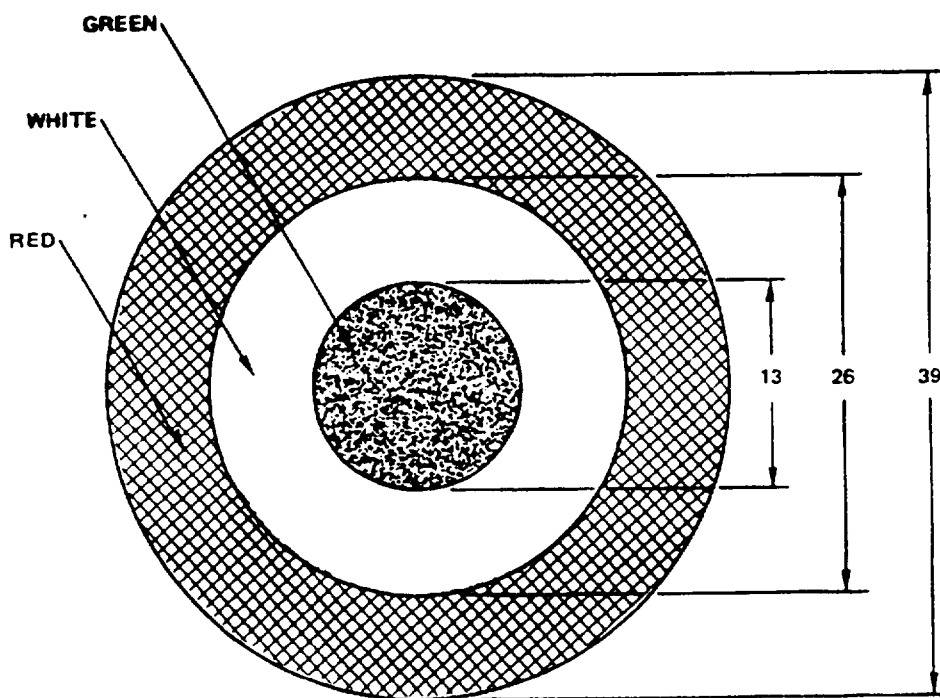
ROUNDEL MARKING III

FIGURE F-20. National insignia of Federal Republic of Germany.

MIL-STD-2161A(AS)



INSIGNIA A

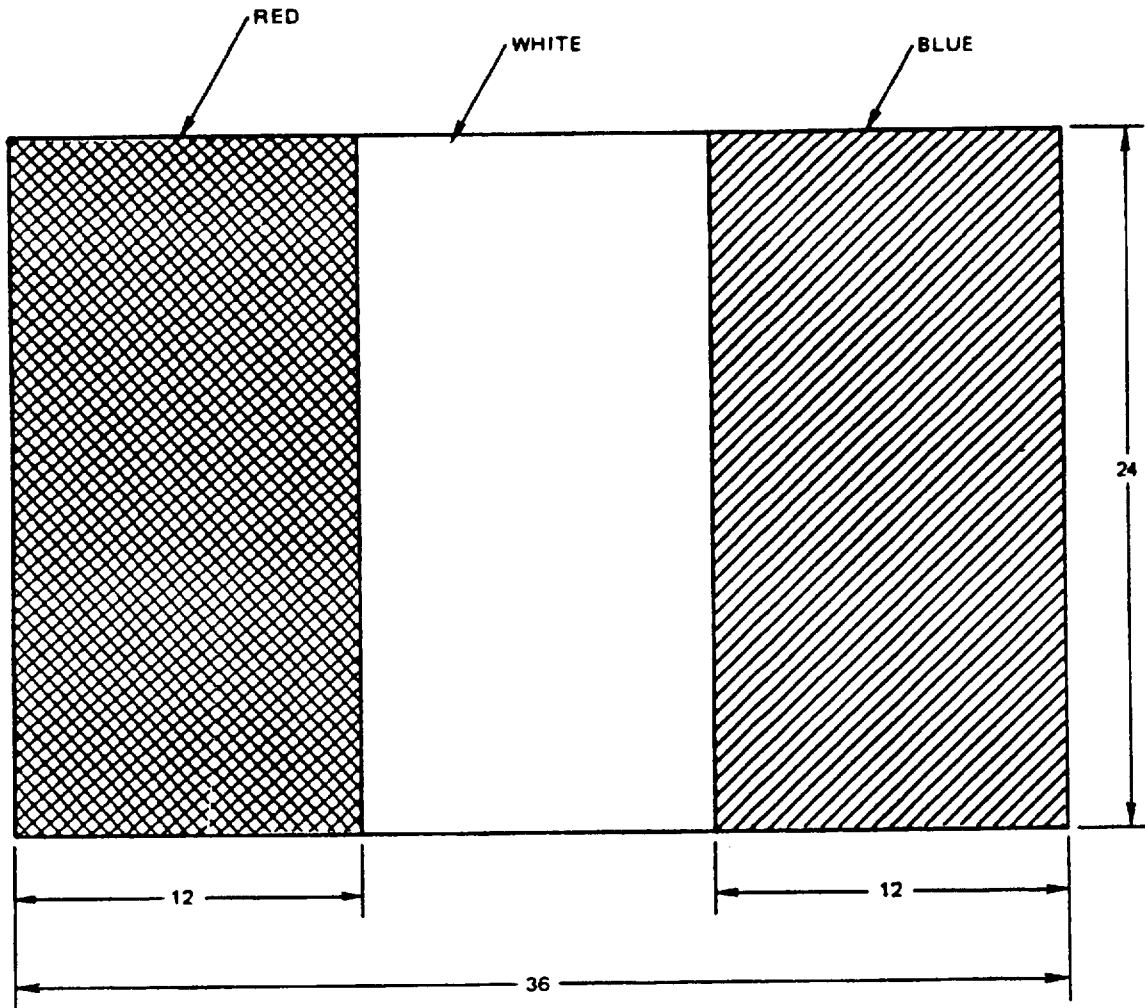


INSIGNIA B

DIMENSIONS IN INCHES

FIGURE F-21. National insignia of Italy (cocarde).

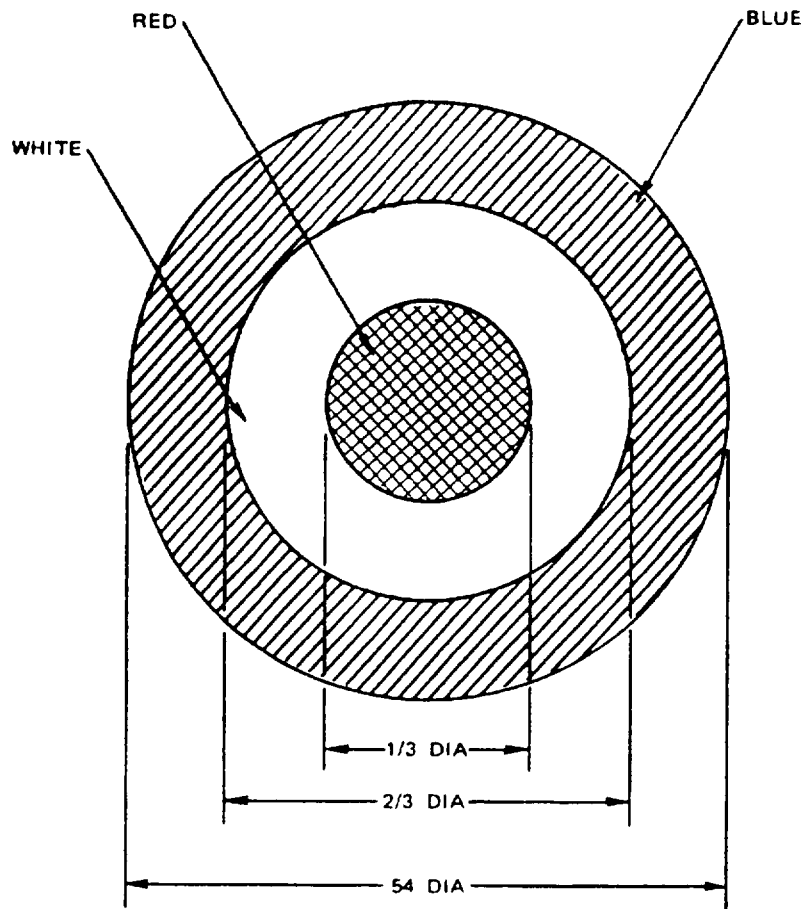
MIL-STD-2161A(AS)



DIMENSIONS IN INCHES

FIGURE F-22. National insignia of New Zealand (roundel) marking I.

MIL-STD-2161A(AS)



DIMENSIONS IN INCHES
DIMENSIONS SHOWN ARE FOR P-3 AIRPLANE

FIGURE F-23. National insignia of New Zealand (flash) marking II.

STANDARDIZATION DOCUMENT IMPROVEMENT PROPOSAL

INSTRUCTIONS

1. The preparing activity must complete blocks 1, 2, 3, and 8. In block 1, both the document number and revision letter should be given.
2. The submitter of this form must complete blocks 4, 5, 6, and 7.
3. The preparing activity must provide a reply within 30 days from receipt of the form.

NOTE: This form may not be used to request copies of documents, nor to request waivers, or clarification of requirements on current contracts. Comments submitted on this form do not constitute or imply authorization to waive any portion of the referenced document(s) or to amend contractual requirements.

I RECOMMEND A CHANGE:

1. DOCUMENT NUMBER

MIL-STD-2161A (AS)

2. DOCUMENT DATE (YYMMDD)

930501

3. DOCUMENT TITLE

PAINT SCHEMES AND EXTERIOR MARKINGS FOR U.S. NAVY AND MARINE CORPS AIRCRAFT

4. NATURE OF CHANGE (Identify paragraph number and include proposed rewrite, if possible. Attach extra sheets as needed.)

5. REASON FOR RECOMMENDATION

6. SUBMITTER

a. NAME (Last, First, Middle Initial)

b. ORGANIZATION

c. ADDRESS (Include Zip Code)

d. TELEPHONE (Include Area Code)

7. DATE SUBMITTED

(1) Commercial

(YYMMDD)

(2) AUTOVON
(if applicable)

8. PREPARING ACTIVITY

a. NAME COMMANDING OFFICER, NAVAL AIR
WARFARE CENTER AIRCRAFT DIVISION LAKEHURST
SYSTEMS REQUIREMENTS DEPARTMENT

b. TELEPHONE (Include Area Code)

(1) Commercial

(2) AUTOVON

(908) 323-7488

624-7488

c. ADDRESS (Include Zip Code)

CODE SR3
LAKEHURST, NJ 08733-5100

IF YOU DO NOT RECEIVE A REPLY WITHIN 45 DAYS, CONTACT:
Defense Quality and Standardization Office
5203 Leesburg Pike, Suite 1403, Falls Church, VA 22041-3466
Telephone (703) 756-2340 AUTOVON 289-2340